

KOVACS

DESIGN FURNITURE

ANGER
100VOLTS

VOLUME 03

**MADE.
RIGHT.
HERE.**

INVEST IN QUALITY NEW ZEALAND MADE FURNITURE
THAT'S MADE BY HAND AND KNOWN BY HEART.

KOVACS
DESIGN FURNITURE

ELTON MODULAR LOUNGE

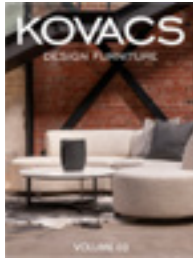

FRONT COVER:
Elton Modular Lounge,
Mason Circular Coffee
Table Large



BACK COVER:
Shabby Duke Settee

KOVACS MANUFACTURED PRODUCTS ARE
AVAILABLE FROM SELECT STOCKISTS AND DESIGN
PROFESSIONALS THROUGHOUT NEW ZEALAND.

See page 89 for our stockists list.
(CURRENT AT TIME OF PRINT)

*Welcome to our new
catalogue for 2021.*

Please browse our range here
and check for more information
and new designs throughout
the year on our website.

kovacs.co.nz

CONTACT INFO

**KOVACS DESIGN FURNITURE- FACTORY,
ADMINISTRATION & TRADE SHOWROOM**

1000 Ferry Road
Ferrymead
Christchurch 8023
Canterbury
New Zealand

Phone: 03 384 2999

E-mail: info@kovacs.co.nz

KOVACS AUCKLAND TRADE SHOWROOM

159 Design
Cnr Great North Road + Sussex Street
Grey Lynn, Auckland 1021

Contact: Samantha Hurd 027 493 6004

E-mail: samanthah@kovacs.co.nz

*Trade showrooms open weekdays,
viewings by appointment*

WELLINGTON DESIGN LIBRARY

Contact: 04 384 1801

Please see website for address details

KOVACS
DESIGN FURNITURE



CONTENTS

- 10 LOUNGE
- 32 MODULAR LOUNGE
- 47 CHAIRS
- 60 RECLINER LOUNGE
- 63 PUREMOTION
- 70 HARD FURNITURE
- 73 AMALFI
- 76 OTTOMANS
- 80 Sustainability
- 82 Leather
- 85 Wood
- 88 Index
- 89 Our stockists
- 90 Our history



**DETROIT MODULAR LOUNGE
AND BRONTE COFFEE TABLE**



GIBBSTON SETTEE, GIBBSTON CHAIR AND PARK-A
SQUARE COFFEE TABLE WITH MARBLE TOP



AXLE SETTEE, MALTA CHAIR, MASON CIRCULAR
COFFEE AND SIDE TABLE AND SQUARE SIDE TABLE

LOUNGE

With sleek lines and sophisticated bearing the modern lounge can make an exceptional design statement while providing complete comfort. There are many different ways to enjoy such furniture. Our recommendation? Grab a good book and a drink, put your feet up and with no nagging second thoughts, to-do lists or other distractions, slip into utter, unequivocal relaxation.

AXLE

Named for the robust steel frame at its heart, the Axle is a minimalist masterpiece with complex attraction. Simple and masculine in form, the imposing steel frame is striking from a distance while providing industrial strength in functionality. This frame sets up a surprising contrast to the comforting lines of the cushioning, which combines feather and foam. The feather-filled arms create a plush, pliable surface to sink into which, together with the crafted seat and back, brings you a new level of comfort. Although it seems incongruous, the Axle really is strong and soft at the same time. It's a blend of the qualities most valued by Kovacs.

DIMENSIONS (CM)	WIDTH	DEPTH	HEIGHT
Chair	101	92	81
2.5 Seater	185	92	81
3 Seater	217	92	81
3.5 Seater	240	92	81
Seat height			46



BROOKLYN

The Brooklyn's peaceful symmetry and astute simplicity allow it to sit easily in apartments or open spaces. A low back and level arms keep the silhouette compact and tight upholstery ensures a neat appearance over time with both fabric and leather as options. The slim plinth adds finer detail to an otherwise substantial piece and balances the circular elements with contrasting angles. Wooden legs, long and tapered, elevate and soften the profile. With a sturdy Southland beech frame, reinforced by steel in the two larger sizes, the shape is designed to last. In a world where extremes are easy and design is disposable, the Brooklyn stands out as a study in composure and balance.

DIMENSIONS (CM)	WIDTH	DEPTH	HEIGHT
2 Seater	153	85	71
2.5 Seater	181	85	71
3 Seater	213	85	71
3.5 Seater	236	85	71
Seat height			45



CLUB

Specifically designed for apartment living, the medium height Club provides generous seat depth and width without overpowering any space. Available as a chair and settee in multiple widths, the Club can be covered in either fabric or leather. When upholstered in leather the standard saddle trim stitching uses a matching colour to add strength and character. However a contrast stitching colour can be requested to create a look all your own. Club has fixed seats.

DIMENSIONS (CM)	WIDTH	DEPTH	HEIGHT
Chair	101	88	83
2 Seater	146	88	83
2.5 Seater	187	88	83
3 Seater	206	88	83
Seat height			48



BROOKLYN SETTEE

DAKOTA

Modern lines combine with luxurious comfort in the Dakota. At first glance the cut-away angles and distinctive cone leg give the appearance of pared back style. In contrast to this the cushioning provides a clear invitation for relaxation, the Ergofill packed seat and back cushions giving both a plump feather-down appearance and enduring comfort. Whether covered in fabric or leather the Dakota brings contemporary style to any room. Seat and back cushions are reversible. Now available with removable body covers.

DIMENSIONS (CM)	WIDTH	DEPTH	HEIGHT
Chair	82	92	78
2 Seater	145	92	78
2.5 Seater	180	92	78
3 Seater	209	92	78
3.5 Seater	232	92	78
4 Seater	255	92	78
Seat height			45



GIBBSTON

The rugged, elemental base and tranquil backdrop of Gibbston Valley provided all the inspiration needed for this settee and chair design. Just like the renowned grape-growing destination so too does this model look alluring from every angle, the elegant curved back ensuring it can settle down into the background or stand out in the middle of the room. Quality construction makes the difference, pre-bent and straight steel components creating shape and strength while allowing cushioning and other design elements to combine with grace and style. Plush and bold without being too flashy or 'of-the-now', the Gibbston, like a good vintage, will reward those in the years to come.

DIMENSIONS (CM)	WIDTH	DEPTH	HEIGHT
Chair	105	94	86
2.5 Seater	181	94	86
3 Seater	213	94	86
3.5 Seater	236	94	86
Seat height			48



GRACE

Sophisticated and sumptuous, retrospective and romantic, the Grace is undoubtedly an investment in refinement. While bold and effortless in bearing, closer inspection of the Grace uncovers clever little details. Along with the careful balance between authoritative lines and enticing curves the octagonal tapered legs provide a distinct look and lightness of manner. Three different densities of seat foam and two in the back deliver plush comfort and hours of luxurious repose. The craft of artisan furniture design is about such details. In the Grace such craft is at its pinnacle. Available in a plain non-fluted back and seat option.

DIMENSIONS (CM)	WIDTH	DEPTH	HEIGHT
Chair	87	86	73
2 Seater	137	86	73
2.5 Seater	165	86	73
3 Seater	196	86	73
4 Seater	242	86	73
Seat height			44



GROOVY

Now is the time to get back into your groove. The Groovy chair and couch provide timeless sophistication and superior structural and surface integrity. The chair, available in both fabric and leather, is a laid-back, deceptively spacious piece. With its stylish leather demeanour the couch is both elegant yet slightly irreverent, a look that matches the decorative demeanour with pure design functionality.

DIMENSIONS (CM)	WIDTH	DEPTH	HEIGHT
Chair	90	88	89
2.5 Seater	167	88	89
3 Seater	197	88	89
Seat height			45



KOVACS
DESIGN FURNITURE



GRACE SETTEE AND
AUSTIN CHAIR



GROOVY SETTEE, GROOVY CHAIR AND
MASON CIRCULAR COFFEE TABLE

HEATH

With a smaller than expected footprint and plush cushioning the Heath shares a family resemblance to the Bronte. This is an earthy piece, a snug, comforting couch. With a narrow frame it is also an excellent and efficient use of space. The design can define a space without dominating it. The eight-sided leg and simple lines ensure it looks great from all angles. The layered foam of the seat cushion, deep soft side and luxurious back cushioning sends out an invitation to nestle. You can now extend the seat and back cushions to the arm with the option of a smaller side cushion. The Heath blends into any environment – the timeless form and long-lasting comfort will keep this piece fresh for years to come. Now available with removable body covers.

DIMENSIONS (CM)	WIDTH	DEPTH	HEIGHT
Chair	98	92	76
2.5 Seater	176	92	76
3.0 Seater	208	92	76
3.5 Seater	231	92	76
Seat height			44



HENLEY

The design of the Henley delivers from-the-past glamour and in-the-now sophistication. This is a transitional piece, designed to sit equally well in a century-old wooden-floored bungalow or a sleek, ultra-modern setting. The English rolled-arm style, wide and accentuated with a slight outward roll, creates the spacious feeling the style is known for. The thick seat cushions are contoured for maximum comfort. Additional elements place the design firmly in the present day. The balanced proportions of the steel base provide an efficient solidity and easy compatibility with other modern pieces. As an alternative option we have created a tall turned leg to further the turn-of-the-century feel.

DIMENSIONS (CM)	WIDTH	DEPTH	HEIGHT
2.5 Seater	190	95	72
3 Seater	222	95	72
3.5 Seater	245	95	72
Seat height			44



INTRIGUE

What is under the surface of the Intrigue? We can tell you that the bonded layered foam structure provides soft, sumptuous comfort. That the adjustable headrest and seat depth uncovers a hidden position ideally suited to your shape. That the perfect mix of modern style and functionality offers years of comfort ahead. Irrespective of what we say here, it will prove an enigma until you take a seat in one. Now is the time to find out the answer for yourself.

DIMENSIONS (CM)	WIDTH	DEPTH	HEIGHT
2.5 Seater	198	95-135	79/95*
3 Seater	224	95-135	79/95*
3.5 Seater	247	95-135	79/95*
Seat height			45

*headrest up**



JED

Classic, clean and contemporary, the Jed's simplicity of design belies its focused bearing and clever adaptability. Sitting upon a timber or steel plinth base Jed may at first seem angular, even severe. But that potential sharpness is circumvented with edges softened by gentle curves and the careful balance overall of aesthetic appeal and physical comfort. This provides a fresh settee with confident simplicity and style. Wide arms and the charcoal coated base are standard, both a timber base and narrow arms are options. Devised to suit any number of coverings, makes the Jed a truly versatile piece suiting both residential and commercial spaces.

DIMENSIONS (CM)	WIDTH	DEPTH	HEIGHT
Chair	82/104*	82	79
2 Seater	139/161*	82	79
2.5 Seater	163/185*	82	79
3.0 Seater	195/217*	82	79
3.5 Seater	228/250*	82	79
Seat height			43.5

*wider arm**



timber plinth base

steel plinth base

narrow arm

JIGSAW

The Jigsaw is a compact settee with a stylish, contemporary feel. Its proportions are low and sleek with slim arms allowing maximum seating comfort while keeping the Jigsaw foot print to a minimum. The beauty and versatility of this design is a discrete yet functional feature...the back cushions are shaped to be easily raised giving extra seat depth and back height to support shoulders. The highly resilient back cushions offer the ultimate combination of comfort and practicality. Together with the commercial grade seat foam and suspension, luxurious seating is ensured. The original finely proportioned arms are now available in a slightly wider option that adds 8cm to the overall width of each settee/ chair, both are well padded to add to your overall comfort, a round bolster is standard or there is an option of a side cushion. The Jigsaw has, at its core, a solidly built frame that will provide years of enjoyment.

DIMENSIONS (CM)	WIDTH	DEPTH	HEIGHT
Chair	89	98	73/89*
2.5 Seater	162	98	73/89*
3 Seater	194	98	73/89*
3.5 Seater	217	98	73/89*
4 Seater	240	98	73/89*
Seat height			50

*headrest up**



new side arm cushion

round bolster

LINCOLN

With bold styling and solid construction the Lincoln evokes a classical approach to furniture design – the look of yesteryear, updated for the here and now. As with the original chesterfield, the deep buttoning and upright bearing provides an enduring sense of sophistication. However the Lincoln goes beyond its influences, which results in a settee suitable for everything from enhancing the small apartment to refining the upmarket hotel suite. Seat cushions available using Ergofill.

DIMENSIONS (CM)	WIDTH	DEPTH	HEIGHT
Chair	90	85	74.5
2 Seater	145	85	74.5
3 Seater	200	85	74.5
4 Seater	246	85	74.5
Seat height			46





LOFT SETTEE AND MANTIS CHAIR,
MASON CIRCULAR SIDE TABLE



MARLOW SETTEE AND MARLOW CHAIR,
MASON CIRCULAR SIDE TABLE

LOFT

This furniture needs to work from every angle, and filling a functional, physical and aesthetic role from any perspective can be difficult. That's why we're so proud of the Loft. At once inviting, enchanting and unexpected, the settee is somewhat of a visual contradiction – a sturdy, grounded and enduring piece that also appears to gracefully float above its surroundings. With captivating design appeal from all angles the Loft's clean, efficient lines provide room to stretch out and the highest quality commercial foam entices you to do so.

DIMENSIONS (CM)	WIDTH	DEPTH	HEIGHT
3 Seater	213	100	76
3.5 Seater	245	100	76
Seat height			46



LYNX

The relaxed profile and generous proportions of the Lynx offers instant and enduring comfort. Soft, supportive and seductive, it's subtle curves and strong construction has been designed to provide ergonomic wellbeing and artisan style. At ease in both residential and commercial settings, and available in a range of fabric coverings, the Lynx is an adaptable piece that covers a range of aesthetic requirements. The Lynx is available with either a narrow arm version or the original wide arm.

DIMENSIONS (CM)	WIDTH	DEPTH	HEIGHT
Chair	92/106*	88	77
2.5 Seater	168/182*	88	77
3.0 Seater	200/214*	88	77
4.0 Seater	246/260*	88	77
Seat height			44
			<i>wider arm*</i>



MARLOW

The Marlow deserves positioning where it can be seen from all angles. Interesting elements within the design, such as the angled relief of the arm backs, repeated in the slant of the solid legs, are as attractive to the eyes as the cushioning is to the body. While the legs provide a solid aesthetic grounding the settee, it is in fact remarkably compact. This contemporary design suits any modern or transitional setting. Whether you are ensconced in the settee or simply gazing in admiration from across the room, the Marlow will give pleasure to anyone who chooses it.

DIMENSIONS (CM)	WIDTH	DEPTH	HEIGHT
Chair	82	87	79
2 Seater	141	87	79
2.5 Seater	167	87	79
3 Seater	197	87	79
3.5 Seater	220	87	79
Seat height			44



MAVERICK

When it comes to the Maverick big is beautiful – and plush is perfect. An emboldened version of our Lincoln, this settee is both expansive and elegant. Here, the deep diamond buttoning and highest quality materials mean you can stretch out in comfort without compromising an iota of style. Appearing at once nonconformist and at ease the Maverick's at home within an ornate setting, a commercial environment or as an entirely unforgettable stand-alone feature. Seat cushions have the option to be reversible and are also available using Ergofill.

DIMENSIONS (CM)	WIDTH	DEPTH	HEIGHT
Chair	94.5	85	74.5
2 Seater	147	85	74.5
3 Seater	207	85	74.5
3.5 Seater	230	85	74.5
4 Seater	253	85	74.5
Seat height			46



MAX

Good design is as much about what's left out as what's included. For the Max this balance is crucial – the understated style and clean efficiencies providing classic modernist style with a twist. If there's one thing it is, it's more than 'one thing', a hinged back cleverly engineered to extend influence and functionality. Rather than imposing itself the Max compliments the surrounding space – it's at home as much in the small apartment as it is the family living room or the concrete-floored loft space. While the wide arm is anchored with a timber slab foot keeping the profile low and solid, the narrow arm version looks sleek on a contemporary metal 'stiletto' foot, brushed silver or black, and provides a more compact footprint.

DIMENSIONS (CM)	WIDTH	DEPTH	HEIGHT
2.5 Seater	171/195*	95	73/89**
3 Seater	196/220*	95	73/89**
3.5 Seater	220/244*	95	73/89**
Seat height			47/44*
			<i>wider arm* headrest up**</i>



SHABBY DUKE

Shabby by name, sumptuous by nature, the Duke's unique layering, delightful curves and compact frame combine to deliver an aristocratic charm all it's own. With slim padded arms, a gently curvaceous seat and back cushions for an encompassing sense of comfort and the double flange cushioning finish for texture and depth this is furniture that likes to look after its guests. Like it's namesake this seating fits in anywhere with a sophisticated and shambolic swagger. The powder-coated steel frame lifts the seat off the floor in an elegant posture. So too does the compact bearing allow you to maximize space in small rooms without compromising aesthetic impact.

DIMENSIONS (CM)	WIDTH	DEPTH	HEIGHT
Chair	95	92	86
2.5 Seater	165	92	86
3 Seater	190	92	86
3.5 Seater	215	92	86
Seat height			45.5





SIMPLICITY SETTEE AND SIMPLICITY CHAIR
AND MASON CIRCULAR COFFEE TABLE

SIENNA

Compact and with a youthful, contemporary feel, the Sienna's proportions are designed to give maximum seating while taking up minimum space. You can choose between the standard legs or a stylish wooden plinth base. The choice doesn't end there, cushions can be either foam or Ergofill, both are hard-wearing and offer comfort and practicality – Ergofill has the plump feel of feathers without the daily maintenance. You also have the option of removable body covers (with the standard leg option only), so its look can remain fresh through the years. A versatile piece, the Sienna looks great upholstered in a combination of fabrics. Seat and back cushions are reversible.

DIMENSIONS (CM)	WIDTH	DEPTH	HEIGHT
Chair	82	84	80
2 Seater	145	84	80
2.5 Seater	180	84	80
3 Seater	209	84	80
3.5 Seater	232	84	80
Seat height			46



wooden plinth base

standard legs

SIMPLICITY

This chair and settee are built for utter relaxation. The raw charm and relaxed, generous proportions provides a sense of lavish comfort and, while appearing oversized, the settee actually sits within a very compact footprint. Built for two, the chair is a love seat in every sense. At Kovacs we love the versatility of the Simplicity, it's design echoing traditional style while utilising the best of modern material and technique. Perfect for all types of family living, particularly with the peace of mind of removable covers, the Simplicity is comfort made simple – and simple made perfect.

DIMENSIONS (CM)	WIDTH	DEPTH	HEIGHT
Chair	113	102	94
2.5 Seater	161	102	94
3 Seater	193	102	94
3.5 Seater	216	102	94
Seat height			46 (soft)



KOVACS
DESIGN FURNITURE



ELTON MODULAR AND MASON
CIRCULAR COFFEE TABLE



ELEMENTS MODULAR AND
PARK-A SQUARE COFFEE TABLE



LENNOX MODULAR LOUNGE, DUMPTY AND PARK-A
SQUARE COFFEE TABLE WITH MARBLE TOP

MODULAR LOUNGE

Contemporary interior design is shaped by the ever-evolving ways with which we entertain in our homes. Increased demand for modular seating in recent times highlights this change – the ability to adapt space to allow for social interaction that’s both widely inclusive and individually intimate. When you value gathering together this is the furniture range for you.



BRONTE MODULAR LOUNGE WIDER ARM

BRONTE

Take a seat on the hugely comfortable Bronte and enjoy the plush, enveloping support. Put your feet up with a book and drink nearby and you'll never want to leave. In the words of the designer, this is the "ergonomically correct slouch-couch", the perfectly layered foam capable of satisfying even the most discerning. The modular elements also provide layout flexibility and the construction materials durable integrity through the years. It's all without compromise in style too, with contemporary lines and careful stitching providing a modern look that is aesthetically pleasing to the eye. Choose from the extensive range of units to create your perfect adaptable layout - you can now also choose a wider arm.

DIMENSIONS (CM)

	WIDTH	DEPTH	HEIGHT
2.5 Seater Settee	158/164*	92	85
3 Seater Settee	183/189*	92	85
3.5 Seater Settee	208/214*	92	85
Straight Unit Single Standard (no arms)	79	92	85
Straight Unit Single Standard (pair arms)	87	92	85
Straight Unit Twin Standard (no arms)	158	92	85
Straight Unit Twin Large (no arms)	173	92	85
Corner Unit	92	92	85
Ottoman	92	92	47
End Unit Twin Standard (LH/RH arm)	162/165*	92	85
End Unit Twin Large (LH/RH arm)	177/180*	92	85
End Unit Twin Standard with side table (LH/RH arm)	194/197*	92	85
End Unit Twin Large with side table (LH/RH arm)	209/212*	92	85
Straight Unit Twin Standard with side table (no arms)	188	92	85
Straight Unit Twin Large with side table (no arms)	203	92	85
Seat height			47
Coffee Table - Glass Top	120	65	40
Side Arm Cushion	70	50	

wider arm*

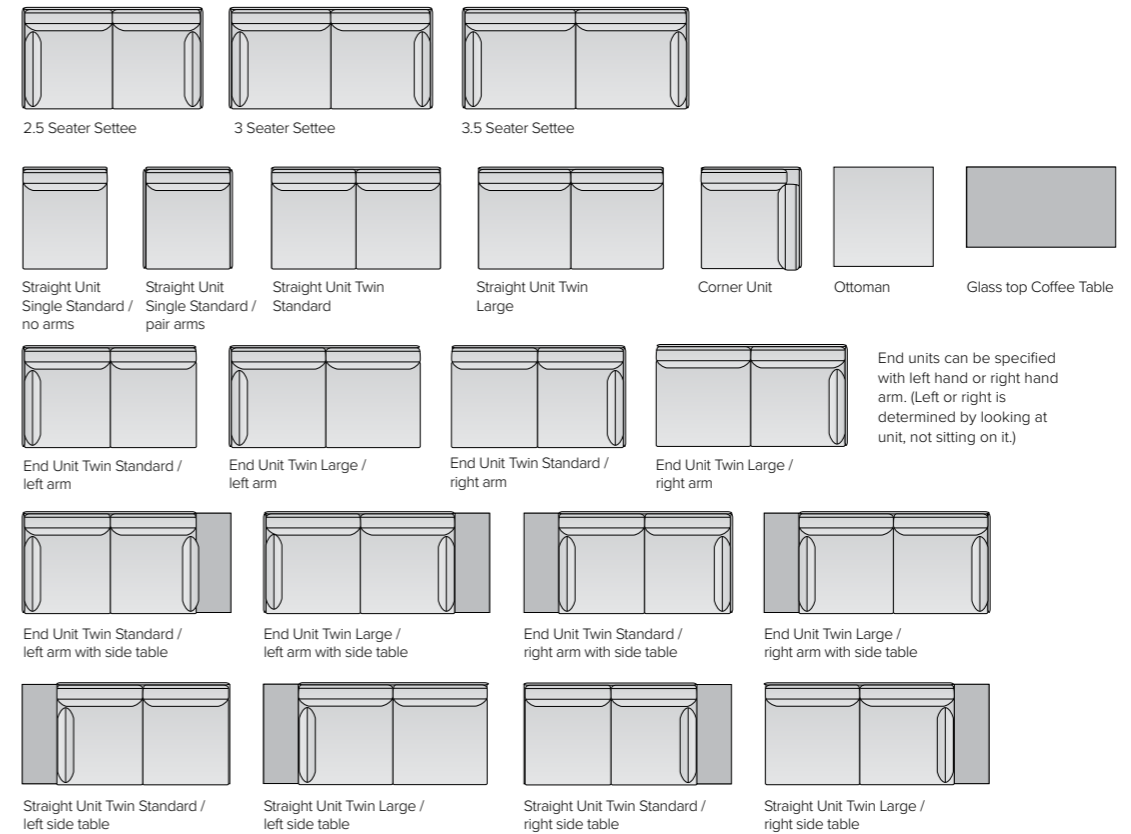

End units can be specified with left hand or right hand arm. (Left or right is determined by looking at unit, not sitting on it.)



DETROIT

Technically complex and elegantly stylish, the Detroit is an architectural piece that's up to date, above the standard and beyond the everyday. While the lines evoke the Loft this settee has an elegant handwriting all its own. The arms are refined, the back filed in, the seat cushioning wraps around and, when necessary, rises up. With solid beech, adaptable MDF and robust steel construction the design is sleek yet strong. Change the combination of fabric and leg colour, and it will fit into any interior environment with succinct, enduring solidity. For 'floating above' European sophistication and at-home functionality the Detroit rises to the occasion. Available with a brushed silver or matte black metal legs.

DIMENSIONS (CM)

2.5 Seater
3 Seater
3.5 Seater
End Unit Single (LH/RH arm)
End Unit Twin (LH/RH arm)
Chaise Unit Single (LH/RH arm)
Seat height

WIDTH	DEPTH	HEIGHT
187	94	70/89*
212	94	70/89*
237	94	70/89*
107	94	70/89*
190	94	70/89*
107	139	70/89*
		44
		headrest up*

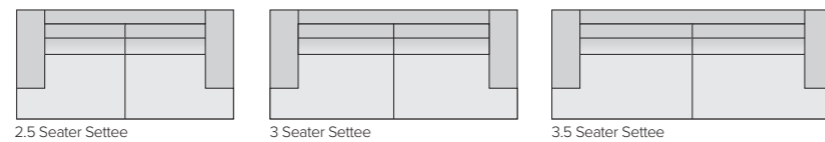

2.5 Seater Settee

3 Seater Settee

3.5 Seater Settee

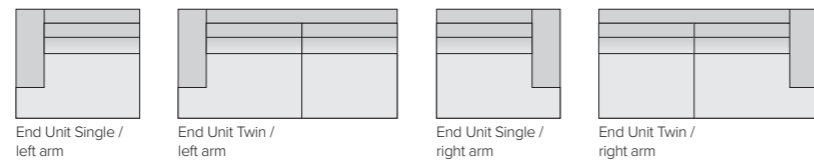

End Unit Single / left arm

End Unit Twin / left arm

End Unit Single / right arm

End Unit Twin / right arm

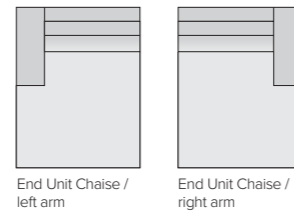

End Unit Chaise / left arm

End Unit Chaise / right arm



ELEMENTS MODULAR LOUNGE AND PARK-A SQUARE COFFEE TABLE



ELEMENTS

This is a design that is both expansive in style and personalised in use. Elements provides a distinctive approach to assembly, both the arms and backs are interchangeable and are able to be moved and locked to the base unit. Creative buttoning and supple, supportive and luxurious cushioning make the overall aesthetic a dream-like one. You can both add to and adapt Elements to suit any environment, being able to evolve a major piece of furniture is a considerable advantage. Interesting colours and fabric choices provide another chance to create a bold individual design statement without compromising ongoing comfort. Now versatile and enduring style is elementary.

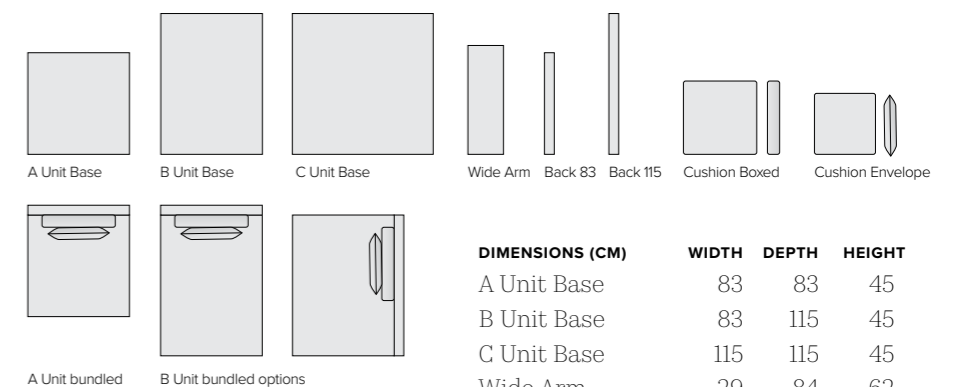

DIMENSIONS (CM)	WIDTH	DEPTH	HEIGHT
A Unit Base	83	83	45
B Unit Base	83	115	45
C Unit Base	115	115	45
Wide Arm	29	84	62
A Back	85	08	80
B Back	115	08	80
Cushion Boxed	60	60	10
Cushion Envelope	50	50	10

ELTON

The Elton is named after the singer known for his incredible style – and for backing the swagger with soul and substance. Here balanced proportions and gentle curves deliver an alluring sensuality and characteristic grace. The versatility of the design works in both commercial and residential settings, the footprint is built around a consistent radius, there's even the ability to create a full circle if you desire or use the two ends together for an intimate conversational nook. The solid framing and springing and superior cushioning comfort ensure both robust durability and lasting ergonomic support. Like the great artist the appeal of the Elton will last across decades.

DIMENSIONS (CM)	WIDTH	DEPTH	HEIGHT
End Unit (LH/RH arm)	165	85	80
Corner Unit	140	85	80
Seat height			46

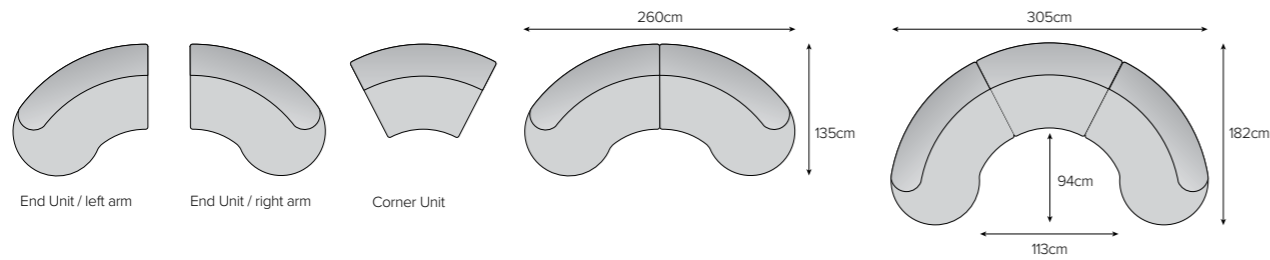

LENNOX

The Lennox has the leanest appearance of all our Kovacs settees, its slim-lined profile ensuring masterful efficiency and graceful comportment without compromising overall comfort in the slightest. Behind the back cushion the frame unfolds to create an adjustable headrest, maximising upper body support and increasing seating depth. The higher than normal seating makes it easy to sink in without struggling to rise. There's a lot going on beneath the surface too, the combination of steel, Southland beech, commercial grade foam and fibre fill ensuring a pitch-perfect end result – hour after hour of rewarding relaxation.

DIMENSIONS (CM)	WIDTH	DEPTH	HEIGHT
Chair	92	95	87/105*
2.5 Seater	177	95	87/105*
3 Seater	200	95	87/105*
3.5 Seater	230	95	87/105*
Single Straight Standard	63	95	87/105*
Single Straight Large	86	95	87/105*
Twin Straight Standard	143	95	87/105*
Twin Straight Large	165	95	87/105*
Twin End Standard (LH/RH arm)	148	95	87/105*
Twin End Large (LH/RH arm)	171	95	87/105*
Twin End with Corner Standard (LH/RH arm)	236	95	87/105*
Twin End with Corner Large (LH/RH arm)	259	95	87/105*
Seat height			46
			headrest up*

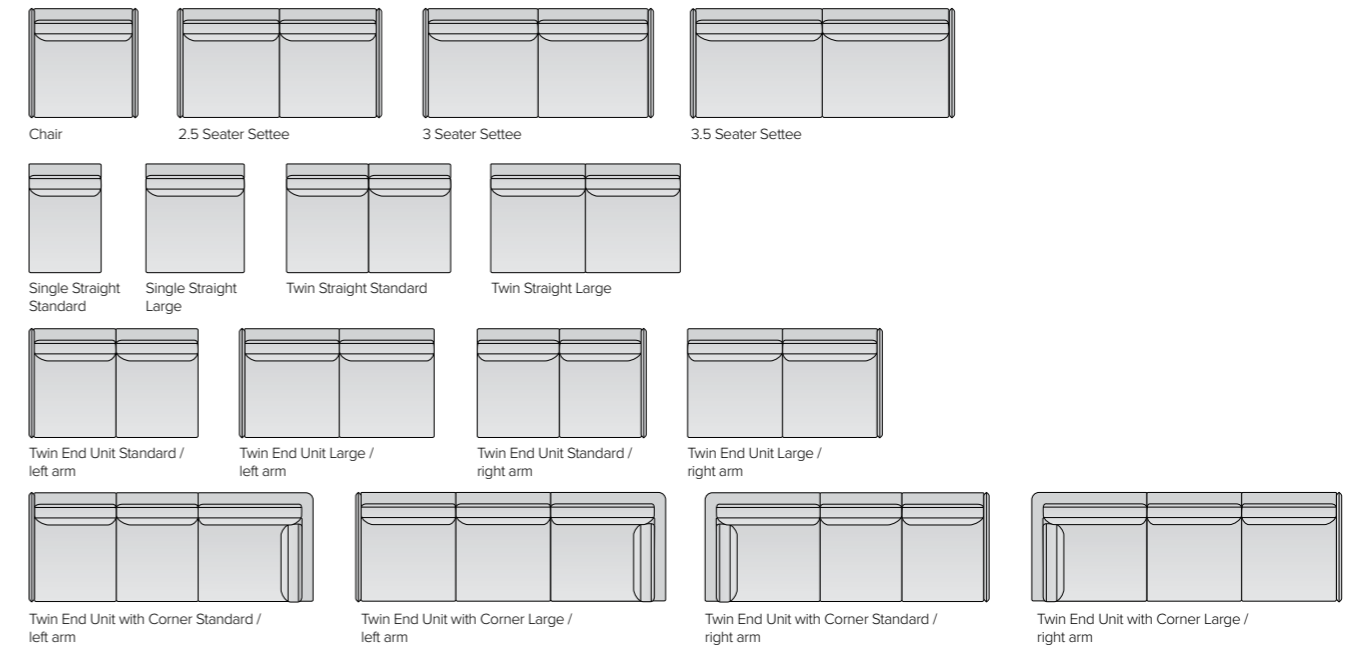

MORGAN

Building on the success of an earlier model, the Morgan introduces a high back, thicker seat cushions and a new level of laminate foam for superior ergonomic support. The level of comfort is backed by solid, enduring design – it will look as good years from today as it does here and now. The adaptability of the Morgan is not limited to its settee or modular layout either. Create a fabric finish that is unique to your style. Change the arm placement to ensure efficiency of space. Choose the feet, contemporary metal 'stiletto' foot, brushed silver or black, or wooden peg leg, to step in sync with your space. Now available with removable body covers.

DIMENSIONS (CM)

	WIDTH	DEPTH	HEIGHT
2 Seater Settee	183	95	82
3 Seater Settee	249	95	82
4 Seater Settee	316	95	82
Straight Unit Twin	135	95	82
Straight Unit Triple	202	95	82
Ottoman	68	95	44.5
End Unit Twin (LH/RH arm)	159	95	82
End Unit Triple (LH/RH arm)	225	95	82
Chaise Unit Twin (LH/RH arm)	213	95	82
Chaise Unit Triple (LH/RH arm)	279	95	82
Seat Height			44.5

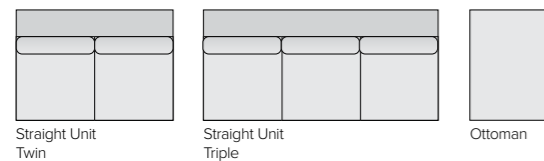
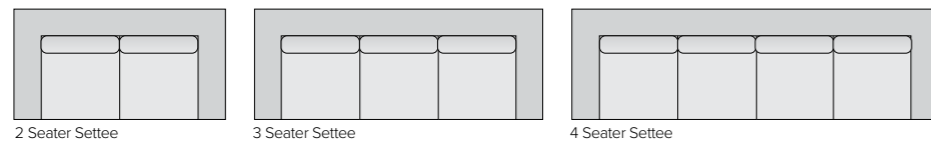

End and Chaise Units can be specified with left hand or right hand arm. (Left or right is determined by looking at unit, not sitting on it.)

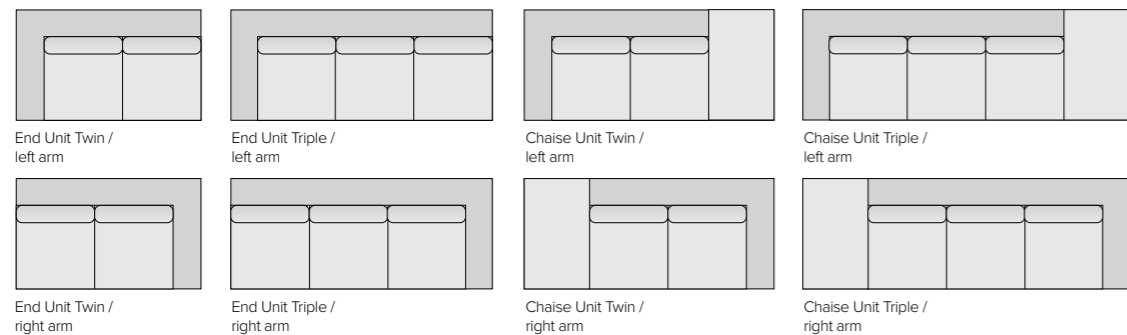

NEWPORT

The Newport offers a snug, stylish and sophisticated approach to modular seating. Its chunky shape and careful construction prove pleasing on the eye and even more on the body. With its clear-cut European lines, compact footprint and flange detailing the couch can easily fit into a range of décor styles. The quality of comfort is considerable also. Here the mid-back height will support the shoulders without the design overpowering the room. The high quality foams provide firm support and the enticement to stretch out and slip into hours of serene relaxation.

DIMENSIONS (CM)

	WIDTH	DEPTH	HEIGHT
2.5 Seater	193	97	76
3 Seater	220	97	76
3.5 Seater	250	97	76
2.5 Seater End Unit Large (LH/RH arm)	168	97	76
3 Seater End Unit Large (LH/RH arm)	195	97	76
3.5 Seater End Unit Large (LH/RH arm)	225	97	76
End Unit Large (LH/RH arm)	109	97	76
End Unit Standard (LH/RH arm)	99	97	76
Corner Unit	97	97	76
Straight Unit Large (no arms)	84	97	76
Straight Unit Standard (no arms)	74	97	76
OT17 - Ottoman Storage	65	97	46
Seat height			46

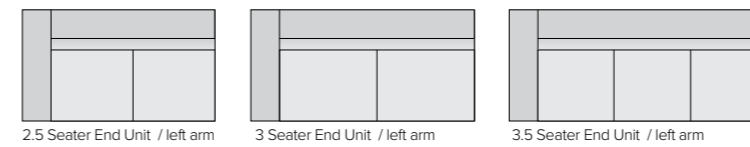
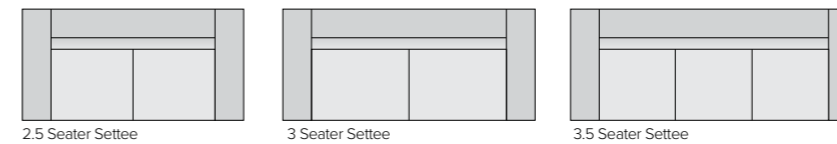

End units can be specified with left hand or right hand arm. (Left or right is determined by looking at unit, not sitting on it.)

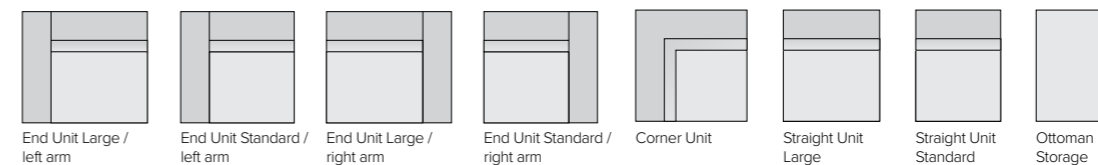
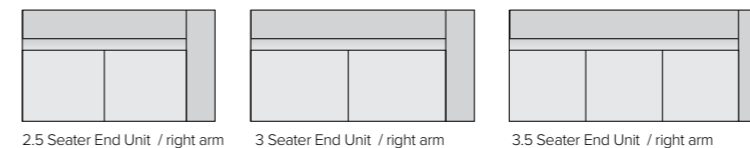



MORGAN MODULAR LOUNGE, SPYDER CHAIR
AND MASON CIRCULAR COFFEE TABLE

QBE

Mix sections, match style, build your QBE. With innovative weighted backs and corner sections this unique range redefines the lounge suite with a sophisticated and adaptable approach to modular seating. The QBE suits both domestic and commercial uses and is ideal seating for foyers. Tetris lovers will certainly love it – not only is it reminiscent of the classic computer game, the QBE can provide just as much joy in its configuration possibilities.

DIMENSIONS (CM)

	WIDTH	DEPTH	HEIGHT
Straight Back Unit (<i>standard size</i>)	90	90	75
Corner Back / End Unit (<i>standard size</i>)	90	90	75
Square Box Base / Ottoman (<i>standard size</i>)	90	90	44
Straight Back Unit (<i>small size</i>)	83	83	75
Corner Back / End Unit (<i>small size</i>)	83	83 </td <td>75</td>	75
Square Box Base / Ottoman (<i>small size</i>)	83	83	44
Seat Height			44

Standard size 90cm²



Straight Unit

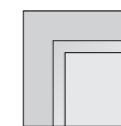

Corner/End Unit



Base/Ottoman

The potential arrangements are only limited by your coordination skills and available space.

Small size 83cm²



Straight Unit

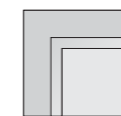

Corner/End Unit



Base/Ottoman



QBE MODULAR LOUNGE



DAKOTA SETTEE, BAXTER CHAIRS, BRONTE COFFEE TABLE AND MASON CIRCULAR SIDE TABLE

CHAIRS

There are a couple of things you'll notice when taking a seat for the first time on a conventional Kovacs chair. First, it's anything but conventional – each chair is carefully developed to deliver both a unique shape and enduring style. Then there's that inescapable feeling of comfort and support. So why not sit back and enjoy it?

AUSTIN

A charming, retrospective take on the occasional chair, the Austin's style is at once both sophisticated and idiosyncratic – it's the chair to add an individualistic manner to your manor. With an attention to detail and a focus on construction the Austin maintains the quality and durability of right now New Zealand while exuding the charm and excitement of mid-century Britain.

DIMENSIONS (CM)	WIDTH	DEPTH	HEIGHT
Chair	67	73	84
2 Seater	120	73	84
Seat height			47



BAXTER

Whimsical from some angles, serious from others, the Baxter is for those who appreciate the unexpected. The striking form uses two frames, each independent of the other. A solid beech external frame (with an option of oak) has a fine-grained texture providing an exquisite finish. The internal frame is constructed from MDF and beech, the strength and longevity of the latter timber ideal here. Careful consideration has also gone into the foam cushioning to support this frame. So, be it commercial or residential spaces, the compact Baxter is designed to create an impression. However, like all our furniture, it's to be enjoyed rather than just observed.

DIMENSIONS (CM)	WIDTH	DEPTH	HEIGHT
Chair	70	84	75
Seat height			44



oak frame option

DIESEL LOW BACK CHAIR

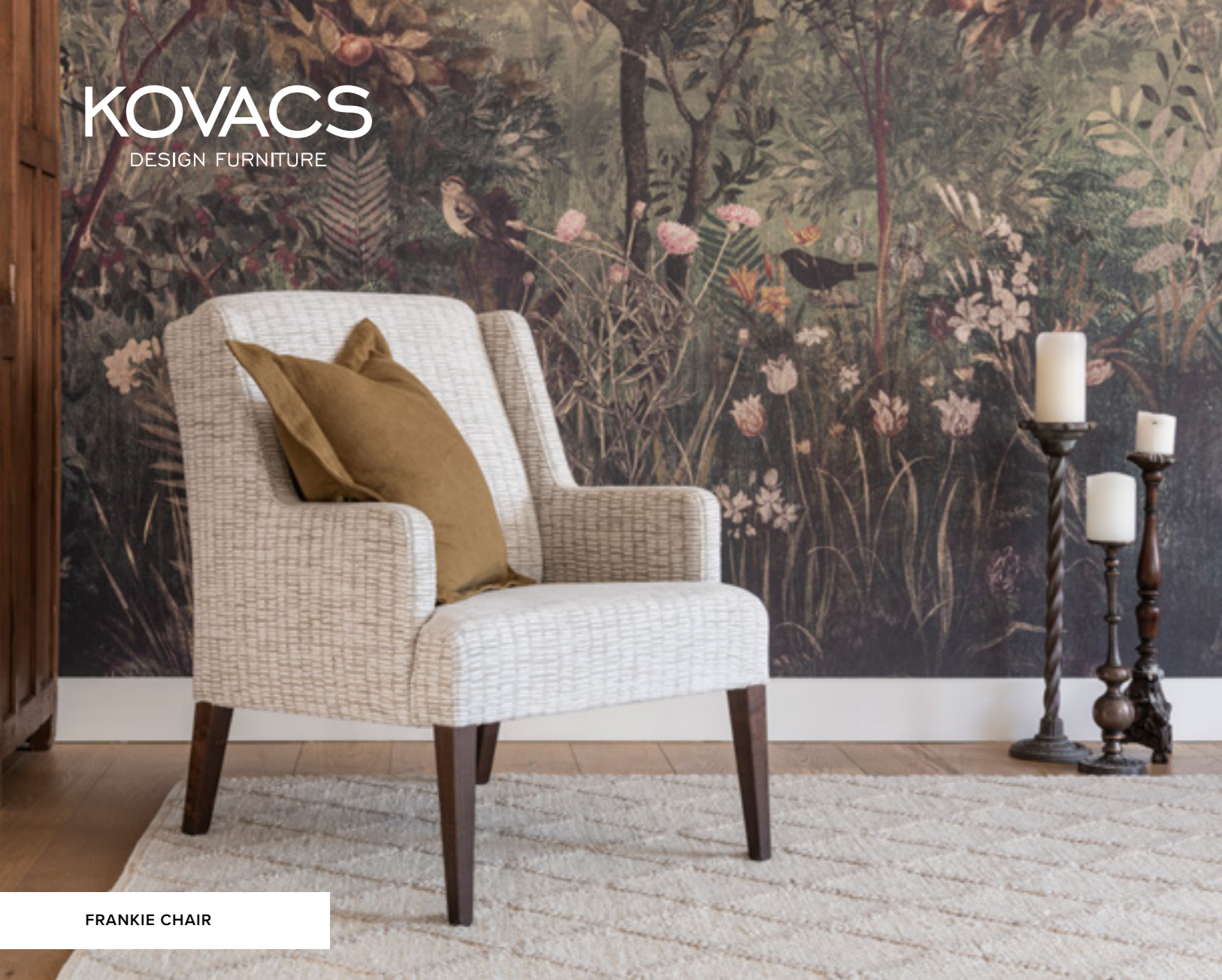

FRANKIE CHAIR

FRANKIE

The reasoning behind the name of this chair should become obvious when it's viewed alongside our popular Franklin model. While the Frankie has the distinctive style and well-padded comfort of it's bigger brother the lower profile, slimmer hind leg and compact footprint of this chair make it suited to a wider range of interior environments in both commercial and residential settings. With huge flexibility in fabric styles and small-but-confident charm this is a chair that can fit in or stand out, with a button look back or plain – the choice is yours.

DIMENSIONS (CM)	WIDTH	DEPTH	HEIGHT
Chair	69	79	92
Seat height			47



Button look back

Plain back

FRANKLIN

The Franklin's plush cushioning and structure offers an elegant solution to a huge variety of interior situations. Contemporary and ergonomically beneficial without being brazen or intrusive, it comes with the choice of a plain or button look seat back and a huge range of fabric finishing choices. With a small footprint this high-backed wing style delivers huge comfort and support for many different body types and the commercial grade foam and strong beech and MDF structure provide heavy-duty durability.

DIMENSIONS (CM)	WIDTH	DEPTH	HEIGHT
Chair	69	80	111
2 Seater	125.5	80	111
Seat height			48



DIESEL

The Diesel is available as both high and low back and, with fabric and leather finishes to suit your specific requirements. The Diesel doesn't have to try hard to impress with bold innovation or flashy gimmickry. Instead it does one thing, and does it well. If you don't believe everything that you read then simply take a seat and discover that thing. Ergonomically tailored, delivering comfort and support to hit all the right places, this is a chair that offers simple uncompromised luxurious rest and relaxation.

DIMENSIONS (CM)	WIDTH	DEPTH	HEIGHT
Chair - low back	72	75	85
Chair - high back	72	78	99
Seat height			47



high back

low back

LOUIS

The Louis chair has instant appeal for those who want the best blend of quality, comfort and contemporary design. There's durable frame construction, attention to detail and resilient seat foams, combined with a super web seat suspension system and a generous seat width. The Louis can be made up in either leather or fabric and the sturdy swivel stand base is standard in brushed stainless steel, with an option of a black base.

DIMENSIONS (CM)	WIDTH	DEPTH	HEIGHT
Chair	71	73	79
Seat height			45



new black base



MANTIS CHAIR AND LOFT SETTEE

LUIGI

When space is at a premium but a strong design statement is required the Luigi both fits in and stands out. Comfortable and elegant, this chair offers you a range of construction choices – you can have it with or without upholstered arms and, in a commercial setting, a left or right arm can be added in order to extend the functionality of a set. The quality beech frame construction is also available in a choice of finishes.

DIMENSIONS (CM)	WIDTH	DEPTH	HEIGHT
Luigi A	49	54	87
Luigi C	57	54	87
Luigi Metropol	120	66	87
Seat height			49



MALTA

The award winning Malta is available as a chair, a 2 seater and a 3 seater settee. With timeless appeal this design looks great in either fabric or leather, the polished wooden arms and dark walnut-finish legs helping it stand out while offering every incentive to sit down and settle in. Steel spring suspension and highly resilient seat foam provide excellent support and, depending on the choice of covering, its form can suit a huge range of fashion too.

DIMENSIONS (CM)	WIDTH	DEPTH	HEIGHT
Chair	75	85	78
2 Seater	143	85	78
3 Seater	203	85	78
Seat height			43



MANTIS

The supple, curved and modular bearing provides encompassing support to the body and steel legs that echo the unique angles of the praying mantis - the Mantis swivel chair certainly has its contrasts. The art deco aesthetic delivers an edgy look and feel while offering simple functionality. The clean, angular lines and laser-cut steel foundation highlight aesthetic style while incorporating structural strength. Such striking design does not come at the cost of comfort or usability, with luxurious cushioning the Mantis encourages rest and relaxation.

DIMENSIONS (CM)	WIDTH	DEPTH	HEIGHT
Chair	64	70	72
Seat height			44



MONTE LARGO

The delicate lines, tough construction and distinct manner of the Monte Largo chair make it a popular choice for interior designers looking to enhance both residential and commercial spaces. With a canny blend of contemporary and traditional this chair, available in fabric or leather, makes a great dining, bedroom or reception piece. With an outside back ring, decorative nailing or braid trim there are several options for the final look of the Monte Largo too.

DIMENSIONS (CM)	WIDTH	DEPTH	HEIGHT
Chair	49	58	89
Seat height			54



NERO

Simple, understated and classically elegant, the Nero chair is perfectly balanced with grace and strength. The durable seat has elasticised multi-strand webbing and the sturdy construction is enclosed with well-fitted covers and trim stitched detail. It's available in two versions as well – the Nero Ground with short, satin-polished pine legs and the Nero Long with legs of satin-polished silver beech.

DIMENSIONS (CM)	WIDTH	DEPTH	HEIGHT
Chair Ground	65	65	87
Chair Long Leg	65	65	88
2 Seater Ground	122	65	87
2 Seater Long Leg	122	65	88
Seat height			49



Nero long leg

Nero ground

ROMA

Bridging the gap between the large lounge and the small cocktail chair, the Roma easily fits into a variety of seating settings. Available in two versions (upholstered or with wooden legs), the Roma has a reversible back cushion, full high resilience foam padding and availability in either fabric or leather. Whatever choice is made in construction the final result will be the same: refined style, superb comfort and many years of pleasurable use.

DIMENSIONS (CM)	WIDTH	DEPTH	HEIGHT
Chair Fabric Leg	70	76	81
Chair Wood Leg	70	76	81
2 Seater	127	76	81
Seat height			46



wooden leg

upholstered leg

SPYDER

It's been dubbed 'the little chair that will go anywhere' by our team. The Spyder works well with larger pieces or, with a bold colour or textured fabric, become a centerpiece in its own right. The elegant legs have a delicate appearance that belies their true strength. Constructed in welded steel, powder-coated and bolted, they deliver a compact silhouette for the deceptively spacious seat. This adaptability is matched by comfort, which is a hall mark of all Kovacs product. Spyder now has an option of a matt black swivel base.

DIMENSIONS (CM)	WIDTH	DEPTH	HEIGHT
Chair	79	73	70
Seat height			43



swivel base

TANGO

For those who are passionate about style and colour the design of the Tango dances to a different beat. It's backed by a solid stance too – the sturdy frame construction and resilient seat foam works well with the web seat suspension system to ensure lasting comfort. For a change in tempo the Tango can also be made in leather or fabric, with the option of the grounded swivel or new star base swivel.

DIMENSIONS (CM)	WIDTH	DEPTH	HEIGHT
Ground Swivel Chair	71	72	74
Seat height			45.5
Swivel Chair	71	72	75
Seat height			47



ground swivel chair

swivel chair

TAYLOR

Ideally suited for small spaces the incredibly comfortable Taylor stands out with its unique style and design, providing both personality and functionality. The strongly built frame provides the structure supporting gentle internal & external curves resulting in both visual and physical harmony. With care in the design process the Taylor delivers the customers most crucial demand, a comfort that is both supportive and cosy. With tall square tapered timber legs the Taylor maintains a compact, funky demeanor, looking superb in a variety of fabric or leather finishes. This design sits well in both residential and commercial environments.

DIMENSIONS (CM)	WIDTH	DEPTH	HEIGHT
Chair	73	74	70
Seat height			45





TANGO STAR BASE SWIVEL CHAIR, DETROIT
MODULAR LOUNGE AND BRONTE COFFEE TABLE

VERDI

The Verdi delivers equal amounts of attitude and adaptability. Be it classic or contemporary its clean, simple lines ensure this chair fits easily into a wide range of residential and commercial settings. It's adaptable in construction too. Available as a chair and settee, the seat cushions are reversible and the back cushions removable. It can be covered in fabric or leather and the solid wood arms and legs look great in a variety of finishes.

DIMENSIONS (CM)	WIDTH	DEPTH	HEIGHT
Chair	76	96	78
2 Seater	135	96	78
Seat height			44



ZOE

The bold lines and confident bearing of the Zoe makes it a great choice for the stylish modern home. Here, the extended back is both elegant and supportive – providing years of quality reading, conversation and relaxation time. Available as either a chair or two-seater, and with a high or low leg. A considered choice of leather or fabric also ensures the final look of the Zoe stands out with a solid, simple and effective design statement.

DIMENSIONS (CM)	WIDTH	DEPTH	HEIGHT
Chair - low leg	72	72	98/102.5*
2 Seater	141	72	98/102.5*
Seat height			45/49*
Footstool	48	50	45

*high leg**





HEATH SETTEE, DIESEL CHAIR, DUMPTY, PARK-A
OBLONG COFFEE TABLE AND CONSOLE TABLE



RANFURLY SETTEE

RECLINER LOUNGE

With modern life fast-paced and frenetic some of your best assets will be those that deliver you the opportunity to take a weight off and take it all in. Now is the time to step back from the pack, sink into the luxury and repose and revitalise yourself with unerring support and enduring style. Now is your time to recline.

SOME CLASSICS ARE BETTER UNPLUGGED.

That's why we're so happy we are now able to include the option of a battery pack* for our recliners. The chairs can perform up to 150 cycles on one charge, so it only needs to be plugged in for a quick recharge every now and then. This means you can now move chairs (and people) around the room for a change in scenery without the need for ugly extension cords to trip over.

**The battery pack is an optional feature and is available at an extra cost.*



MURRAY RECLINER CHAIR

EURO

The Euro's tailored style is unassuming but entirely effective – while casual in appearance there's an underlying sophistication in design and construction.

Here the high back, adjustable headrests and spacious depth and width are available in either a fixed model, as a recliner, available motorised, or with a recline/swivel 3D Motion mechanism – the last two options available fitted with the Xtenda footrest or with a chaise option. You really can judge this book by its cover – the Euro is as comfortable as it looks. Optional rechargeable battery powerpack for motorised chair.

DIMENSIONS (CM)	WIDTH	DEPTH	HEIGHT
Chair - fixed	90	94	101
Chair - recliner	90	94	103
Chair - motor	90	94	101
Chair - 3D	90	94	103
Chair - ezi-out	90	94	103
2 Seater	154	94	101
2.5 Seater	170	94	101
3 Seater	200	94	101
3.5 Seater	223	94	101
Seat height			49-50



MERCEDES

Mercedes is designed for exceptional comfort with extra support for neck, shoulder and back. The chairs are available in four standard versions – a recliner, motorised recliner, 3D Motion mechanism that rocks, swivels and reclines and motorised Ezi-out recliner – with a variety of features and options to customise the level of comfort you require. The cushioning material has been enhanced in key areas. Extra high density seat foam, with moulded body foam on top with the upright non-sagging back including extra lumbar support. A high back and optional adjustable headrest provide the ultimate in comfort fine tuning. Swivel castor and heavy-duty castor options add 25mm to seat height. Optional rechargeable battery powerpack for motorised chair.

DIMENSIONS (CM)	WIDTH	DEPTH	HEIGHT
Chair - recliner	82	104	95
Chair - motor	82	104	95
Chair - 3D	82	104	95
Chair - ezi-out	82	104	95
Seat height			49-53

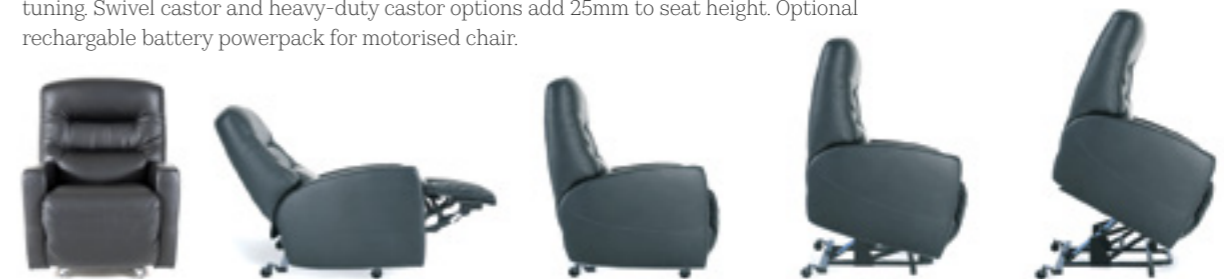

MURRAY

Minimalist and modern while evoking a classic feel of yesteryear, the Murray provides confident style and enduring, luxurious comfort – and it does so all within a conveniently compact footprint. Be it ordered as a fixed chair, a recliner or matching settees, in fabric or leather, the adjustable headrest, ergonomic support and enveloping luxury of this chair provides perfect stress-free seating. Optional rechargeable battery powerpack for motorised chair.

DIMENSIONS (CM)	WIDTH	DEPTH	HEIGHT
Chair	77	88	102
2 Seater	137	88	101
2.5 Seater	161	88	101
Seat height			46



OHOU

When nothing but the utmost rest and relaxation is required the Ohau has support in all the right places. Providing full head and shoulder backing, blissful lumbar support and a shallower seat depth that won't leave shorter people high and dry, it's a chair made for serious sitting contentment. And despite the compact footprint and narrow arm width there's no compromise in the high back comfort and heavy-duty construction. Optional rechargeable battery powerpack for motorised chair.

DIMENSIONS (CM)	WIDTH	DEPTH	HEIGHT
Chair	87	94	100
2 Seater	141	94	100
2.5 Seater	169	94	100
3 Seater	201	94	100
Seat height			45-47



RANFURLY

The Ranfurly chair comes with a high back for supreme relaxation, and is available in three versions - a fixed chair, a recliner activated by a simple push or, a motorised recliner activated with a hand held remote control. The settee, available in both two and three seater options, brings a level of sophistication and glamour to any room. This series has eye-catching turned wooden front legs with a contemporary tapered front leg option also available. Optional rechargeable battery powerpack for motorised chair.

DIMENSIONS (CM)	WIDTH	DEPTH	HEIGHT
Chair - fixed	105	94	101
Chair - recliner	105	94	101
2 Seater	162	92	94
2.5 Seater	192	92	94
3 Seater	221	92	94
Seat height			53
Ottoman 12	57	50	46



SEDDON

The Seddon range is designed for maximum comfort within a compact footprint. The higher seating position and more upright stance suit people who like to remain attentive and active while seated. The chair can be fitted with a manual or a motorized recliner mechanism. Lockable heavy duty wheels can also be specified if required. Settees complete the range. Seat height varies with foot chosen. Optional rechargeable battery powerpack for motorised chair.

DIMENSIONS (CM)	WIDTH	DEPTH	HEIGHT
Chair	75	87	110
2 Seater	134	87	104
2.5 Seater	158	87	104
Seat height			53



PUREMOTION RECLINER CHAIRS

The Puremotion range has been honed to deliver remarkable style and unadulterated relaxation. These chairs offer the maximum of comfort with a reclining back that goes to a near horizontal plane. With no need for a footstool or oversized base there's space to stretch out from a very small footprint. It is no wonder owners of Puremotion become so zealous in their advocacy of these chairs - it's an experience that needs to be enjoyed day after day.



PUREMOTION NICOLE



1 Think a-head. Often the neck and head areas are the first to feel stress and tightness, hence our particular attention in delivering adjustable head and neck support that's ergonomically correct, yet provides supreme comfort while maintaining a streamlined appearance.

2 No slouching about. Some chairs are made for fleeting visits. The Puremotion range has been designed to spend time in. With full ergonomic support for the entire lumbar region it doesn't matter how long you stay, you'll always feel refreshed.

3 Let your fingers do the work. With life placing ever increasing demands on your time and attention, taking the stress out of everyday living means only having to deal with a concealed, easy to use control panel or elegant lever for reclining without the distractions.

4 Function and Fashion. Don't let the sleek design fool you. Attention to detail at the design stage has provided armrests with beautiful, subtle lines that deliver ultimate comfort at every stage.

5 Style from the ground up. All the bases are built tough, yet have a unique, memorable look - covered in leather, a stained wood finish or in aluminium, the swivel base offers 360° rotation, solid support and standout design. Please note: Bases are not interchangeable between models.

6 Don't just sit there. Lie back and relax. The Puremotion integrated footrest delivers that final touch of luxury with out the bulk or inconvenience of a separate ottoman. All models are available either manually or electrically operated.

All models are available with an optional footrest extender. It adds 16 cm to the standard footrest length and flips out to provide leg support for individuals taller than 184cm.

PUREMOTION ELLA

PUREMOTION FEATURES A PATENTED MECHANISM, MADE UNDER LICENSE TO LAFER, SHOWN HERE WITH THE UNDER ARM MOTORISED SWITCH. THE PUREMOTION RANGE OF CHAIRS HAVE A MAXIMUM USER WEIGHT LIMITATION OF 120KG. (265LB OR 18.9 STONE) PEOPLE EXCEEDING THIS WEIGHT SHOULD NOT PURCHASE OR REFRAIN FROM USING THESE CHAIRS. DO NOT ALLOW TWO PEOPLE TO SIT IN THE CHAIR AT THE SAME TIME AS THIS MAY ALSO EXCEED THE WEIGHT LIMITATION.

ADELE

Looks can be deceiving. With a small footprint and a light, Scandinavian design character the Adele at first appears slight and insubstantial. But beneath the surface this chair benefits from incredibly sturdy construction and above it the sitting experience is one of faultless support and incredible comfort. With an extendable headrest providing additional support the Adele is adaptable to a range of settings both in the home and at the office.



DIMENSIONS (CM)	
Total height	100-110
Seat height	46
Total width	74
Between arms	50
Depth upright	80
Depth reclined	160-170

ELLA

The sleek base and 'easy on the eye' design of this chair ensures a strong sense of harmony with its surrounds. With a refined and sophisticated presence the Ella will always compliment a room. It doesn't need to compete for attention - true style never does. It simply draws people in. And that's how this careful combination of wood and covering material creates such a unique experience, one that's both cutting edge and wholly comfortable.



DIMENSIONS (CM)	
Total height	108
Seat height	48
Total width	83
Between arms	56
Depth upright	80
Depth reclined	175

KIRI

There's nothing ostentatious about the Kiri - it's a chair designed and built according to an exacting minimalist belief. You'll find moving from upright into a near horizontal position is a simple, precise movement that will bring pleasure for years to come. Likewise the luxurious upholstery delivers full ergonomic support without over-stylised lines. So there's nothing between you and pure relaxation.



DIMENSIONS (CM)	
Total height	106
Seat height	48
Total width	74
Between arms	50
Depth upright	80
Depth reclined	173

NICOLE

With a robust design profile and solid construction the Nicole delivers a calm authority and distinct comfort, making it ideal for both office and home environments. The full ergonomic support is a great asset for extended stays and a careful attention to detail provides a unique headrest and solid, enveloping armrests. While the base can have a stained plywood finish generally a fabric or leather cover is used to complete the look.



DIMENSIONS (CM)	
Total height	106
Seat height	47
Total width	76
Between arms	54
Depth upright	80
Depth reclined	174



PUREMOTION KIRI WITH
OPTIONAL FOOTREST EXTENSION



INTRIGUE SETTEE, MALTA CHAIR AND
PARK-A OBLONG COFFEE TABLE

HARD FURNITURE

When buying coffee and side tables, drawers and other pieces a learned perspective can make all the difference in the visual character of a room. Our hard furniture range can be matched to other pieces or alternatively positioned as unique individual attractions. Available in a range of wood finishes, steel and engineered quartz, and built to provide timeless style and usability, each piece can equal and elevate the bearing and tone of your room.



MORGAN MODULAR LOUNGE AND MASON CIRCULAR COFFEE TABLE

COMO COMMDES

An elegant chest of drawer combinations can bring out the best in any room. The Como range has been crafted to help you create both unique individual attractions and a cohesive ensemble design. This series was conceived to span two distinct design worlds, where a regal, stately bearing combines with eastern influences to create a new standard of elegance. While each model has a contemporary sophistication they have been designed and built to withstand the test of time.

DIMENSIONS (CM)	WIDTH	DEPTH	HEIGHT
Art 0251 3 Drawer	103	44	86
Art 0253 2 Drawer	103	44	86
Art 0252 2 Drawer Side	50	30	60.5



HUMPTY

It's not just a well-balanced table or convenient resting place. The Humpty footstool also doubles as an extra seat, making it ideal for those 'last minute arrival' occasions when finding enough seats becomes a challenge. When not required these chairs can be neatly tucked away under the coffee table, saving space and setting the scene. The Humpty can be purchased individually or as a set of four with the table in two sizes.

DIMENSIONS (CM)	WIDTH	DEPTH	HEIGHT
OT9 Humpty large	57	57	35
Coffee Table large	116	116	42
OT9 Humpty small	46	46	35
Coffee Table small	95	95	42



MASON TABLES

Providing natural texture to a setting without bulk, the smooth stone surface and slender steel frame assures strength while maintaining a sleek profile. The engineered quartz surface is an accessible alternative to granite or marble. It's hand-worked to create a smooth polish and retains the cool, tactile qualities of natural stone, absorbing and reflecting light in different ways as the day changes. Available in a range of sizes, the Mason stands out while still allowing other pieces within the room to breathe.

DIMENSIONS (CM)	WIDTH	DEPTH	HEIGHT
Circular Coffee Table Lge	102	-	37.5
Circular Side Table Lge	60	-	45
Square Side Table	39.5	39.5	56



PARK-A TABLES

Embracing the style and artistry of parquet, this range at once brightens a room with light tones and fine detailing while anchoring it with solid lines and strong steel framing. The Park-a series is available in two coffee tables, a console table and a side table. Made entirely in our New Zealand factory, the solid oak is mounted onto ply for added stability and then held in a solid steel bar framework. This steel is practical and uncompromising and yet, with its sleek lines and minimalist joins, altogether elegant and light in bearing. Our Park-a steel bases can also be crafted with marble tops - pricing on application.

DIMENSIONS (CM)	WIDTH	DEPTH	HEIGHT
Console Table 01	185	42	70
Coffee Table Ob 01	119	61.5	38
Coffee Table Sq 02	119	119	38
Side Table 01	61.5	61.5	38



HEATH SETTEE AND PARK-A OBLONG COFFEE TABLE

Amalfi

BY KOVACS

The Amalfi range of chairs does not fit into the same box as other furniture. It provides an opportunity to think outside the square, to hone a distinctive look that is uniquely yours and to be at once past and present with your style.

Available in a range of styles, customised in your choice of fabric and wood finishing, contact Kovacs to find out more on our Amalfi range.



AMALFI 0711D



HENLEY SETTEE, LOUIS CHAIR, PLAIN ENZO ROUND OTTOMAN AND PARK-A CONSOLE TABLE

OTTOMANS

Not all ottomans are created equal. Some are content to sit on the sidelines next to their larger relatives. Others step up and demand attention. Our range offers variety in design and construction so, no matter your fashion or function needs, you'll be able to find an ottoman that matches your style.



The Kovacs collection of ottomans comes in a range of sizes and styles to suit any setting. With a choice of three standard shapes they can be constructed in a variety of sizes and the storage ottomans also provide the option of a deep or shallow profile. All Kovacs ottomans can be adapted for flexibility of style too. Depending on the choice of leg you can customise the height of your ottoman or match it to an existing suite. Some ottomans are available fixed or with storage. Height shown on the OT range is furnished height add the height of your chosen leg for overall height. (With the exception of OT11 round).

LEG HEIGHTS (CM)

A = 17
 B = 13.5
 C = 10
 D = 9
 E = 9
 F = 11.5
 G = 13.5
 H = 15.5
See page 85 for wood colour finishes
 I = 17
 J = 15
 K = 13

Available in black

DIMENSIONS (CM)	WIDTH	DEPTH	HEIGHT
Brooklyn	57	64	49
Dumpty	42	42	38
Humpty Large	57	57	35
Humpty Small	45.5	45.5	35
Jed	71	65	43.5
Lacrosse Stool	64	48	42
Morgan	68	95	44.5
Newport*	65	97	46
Ranfurly	57	50	46
Zoe	48	50	45
OT1 Oblong	155	66	42.5
OT2 Oblong narrow*	155	65	29
OT3 Square*	97	97	34
OT4 Square narrow*	97	97	29
OT5 Cuba oblong	155	65	39
OT6 Cuba square	90	90	35.5
OT7 Cowhide	103	103	34
OT11 Enzo round	105	105	35

*Available fixed or storage

BROOKLYN

DIMENSIONS (CM)	WIDTH	DEPTH	HEIGHT
Brooklyn Ottoman	110	70	40



DUMPTY

DIMENSIONS (CM)	WIDTH	DEPTH	HEIGHT
Dumpty	42	42	38

Available detailed in leather or plain in fabric



HUMPTY

DIMENSIONS (CM)	WIDTH	DEPTH	HEIGHT
Humpty large	57	57	35
Coffee Table large	116	116	42
Humpty small	45.5	45.5	35
Coffee Table small	95	95	42



JED

DIMENSIONS (CM)	WIDTH	DEPTH	HEIGHT
Jed Ottoman	71	65	43.5



LACROSSE STOOL

DIMENSIONS (CM)	WIDTH	DEPTH	HEIGHT
Lacrosse Stool	64	48	42

Available with timber or upholstered legs



MORGAN

DIMENSIONS (CM)	WIDTH	DEPTH	HEIGHT
Morgan Ottoman	68	95	44.5



NEWPORT

DIMENSIONS (CM)	WIDTH	DEPTH	HEIGHT
Newport Ottoman*	65	97	46

*Available fixed or storage.



RANFURLY

DIMENSIONS (CM)	WIDTH	DEPTH	HEIGHT
Ranfurlly Footstool	57	50	46



ZOE

DIMENSIONS (CM)	WIDTH	DEPTH	HEIGHT
Zoe Footstool	48	50	45



OBLONG

DIMENSIONS (CM)	WIDTH	DEPTH	HEIGHT
OT1 Oblong*	155	66	42.5

*Available fixed or storage.
Add chosen leg for overall height.



SQUARE

DIMENSIONS (CM)	WIDTH	DEPTH	HEIGHT
OT3 Oblong*	97	97	34

*Available fixed or storage.
Add chosen leg for overall height.



CUBA OBLONG

DIMENSIONS (CM)	WIDTH	DEPTH	HEIGHT
OT5 Cuba oblong	155	66	39

Add chosen leg for overall height.



OBLONG NARROW

DIMENSIONS (CM)	WIDTH	DEPTH	HEIGHT
OT2 Oblong narrow*	155	65	29

*Available fixed or storage.
Add chosen leg for overall height.



SQUARE NARROW

DIMENSIONS (CM)	WIDTH	DEPTH	HEIGHT
OT4 Oblong narrow*	97	97	29

*Available fixed or storage.
Add chosen leg for overall height.



CUBA SQUARE

DIMENSIONS (CM)	WIDTH	DEPTH	HEIGHT
OT6 Cuba square	90	90	35.5

Add chosen leg for overall height.



COWHIDE

DIMENSIONS (CM)	WIDTH	DEPTH	HEIGHT
OT7 Cowhide	103	103	34

Add chosen leg for overall height.



ENZO ROUND

DIMENSIONS (CM)	WIDTH	DEPTH	HEIGHT
OT11 Enzo round	105	105	35

Available buttoned or plain.



LACROSSE STOOL AND ROMA 2 SEATER



SUSTAINABILITY

At Kovacs we are dedicated in working toward a sustainable future and to improving the social economic and environmental well being of our community.

The purpose of this statement is to provide a vision.

A set of guiding principles has been created to ensure our actions support sustainability and improve our environment. All principles being of equal importance.

1. WHOLE OF LIFE VIEW

To ensure all systems in place, their interconnectivity and long term effects, are taken into account when planning.

2. STEWARDSHIP

To communicate internally and externally our responsibilities for the protection, respect and long term management of our environment.

3. COLLABORATION

Working together with our business partners and clients toward this common goal.

4. ANTICIPATION

Being proactive in dealing with risk and the potential effect on our people and environment.

5. EFFECTIVE AND EFFICIENT

To maximise opportunities while being efficient in our practices, resulting in a positive outcome for our people, environment and profitability.

6. LIFECYCLE ASSESSMENT

Continual process of analysis in order to identify opportunities, reduce environmental impact and improve overall value.

7. VALUE PEOPLE

Without our close and extended community we have nothing.

GOING HEAVEN FOR LEATHER

THE SKILL BEHIND LEATHERCRAFT FOCUSES ON SOURCING, ASSESSMENT AND CAREFUL PLACEMENT OF THE VARIOUS GRADES UPON THE FURNITURE.

No two hides are ever quite the same – which means every piece of furniture using this material is unique in its appeal. Get up close to good leather and you'll see the difference. It's the smell, texture, the touch and look of quality that sets a high-end piece apart.

Cheaper 'processed' stock simply does not feel like this. However nor are the most expensive and luxurious leathers necessarily the most practical for furniture in high-risk environments.

With semi-aniline leather there is a minimal amount of processing undertaken, finishing with a light sealer coat to ensure some protection from soiling while still retaining a natural feel. In this way we ensure the right balance of luxurious touch and longstanding toughness.

At Kovacs we have used the same Italian tanneries for two decades now. Back in the mid 90s we were drawn to their passion and commitment to the craft. We're happy to see this mindset has remained undiminished – they are still absolutely dedicated to producing the highest quality leathers.

Once delivered, we need to make the most of the material's different strengths. Each hide naturally has its durable thicker areas and other, more delicate places that can stretch further. Assessing each is a simple but exacting process.

The different zones within each piece of furniture then play a big part in placement. There are wear zones, visible zones, creases and hidden spots. Trying to get the right balance is not a science but an art. First each hide is stretched to identify any imperfections. Then the patterns are marked and graded for each piece of furniture. For example, we can't have high use areas taken from the belly of the hide or the neck grain, as it tends to stretch. While these areas have the least tensile strength (and are the most difficult to work with) they still have intrinsic value however.

Working with leather is a very tactile experience – it rewards those who know what they're doing. The buying process is similar. The true nature of leather is something that continues to reward for decades after purchase. For the educated furniture buyer this enduring style and comfort is worth every cent.

WATCH YOUR HIDE.

LEATHER CARE TIPS

If you've invested in quality leather furniture you'll want to do everything you can to keep it looking good and lasting long.

WHAT TO AVOID

Never use abrasive cleaners or solvents, which can do permanent and irreversible damage. This is a regular issue around Christmas time when, in the rush to get everything ready, people will attack their furniture with all kinds of inappropriate household cleaners.

HOW TO CLEAN

It's very easy, provided you follow the instructions recommended for the leather type of your furniture. Generally all leather requires a two-step process: cleaning and conditioning. Only applying conditioner without first cleaning the dirt and old conditioner off can lead to dirt trapped in the coating. Remember – several light cleans are better than one aggressive approach.

ALWAYS REMEMBER

One common problem when going away for the holidays is excessive sunlight and it pays to move leather furniture away from where direct sun can stay on the furniture. If you want to leave the curtains open shift your chairs and couches away from the window areas. It also helps to rotate furniture regularly throughout the year. This avoids overexposure to just some parts of the furniture, or to certain individual pieces.

USE THE RIGHT CLEANERS

We suggest using cleaning products that provide long-term benefits along with short-term good looks. For the best of these products you don't have to look far either – there's an internationally recognised industry-leader right in our backyard. Pelle Care products are manufactured in Timaru. They've developed top of the line care products that don't cost the earth.

PLEASE BE AWARE

Even with a protective finish leather can still be affected by different chemicals that over time will break down the leathers surface. Hair products like gels, hairspray etc., body lotions and medication leaching out of the skins pores can all impact on the surface finish of your leather product. A regular clean and conditioner/protector coat applied will help keep the surface of your leather in good condition.

LEATHER TYPE & COLOUR.

We don't settle for second best when it comes to our suppliers. Only the most diligent, experienced and forward-thinking tannery will do. That's because, over the years, we've been reminded time and time again that everything starts with the quality of the leather. Our reputation rests on it, our customers relax on it and, with our time-honoured guarantee, we stand by it.

DAKOTA SEMI-ANILINE LEATHER

With a totally natural grain, Dakota exhibits all the characteristics you love most about leather. It is best suited for medium risk wear situations. To help give Dakota that natural look & luxurious touch, it only carries a small amount of the protective coatings applied to heavy use corrected leathers.

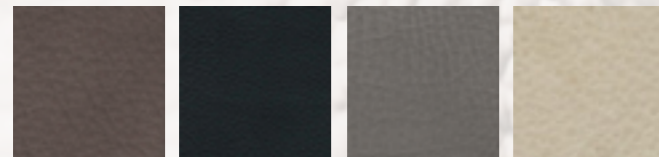

CANELLE CHARCOAL GREYSTONE PARCHMENT

PERLA FULLY FINISHED LEATHER

A fully finished Leather with unique iridescent pearlised surface. Luxurious soft and silky touch. Dyed through, enhanced with oils and protective treatments, very lightly pigmented top grade cow hide. Suitable for medium wear situations. Scars, wrinkles and variations in grain and colour are endorsements of its natural beauty.

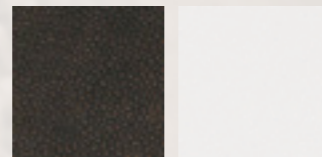

BRONZE WHITE PEARL

MILANO PIGMENTED TOP-COATED LEATHERS

If you love leather but are shy of its ability to stand up to wear, this is the leather for you. Milano is a pigmented top coated leather. That means it has a protective top coat, which helps to provide good resistance to fading, colour loss and some soiling. As such, it is more suitable for medium to heavy wear situations.



DIESEL FOSSIL GARBO ONYX

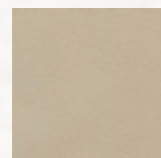

PEBBLE

ROADSTAR SEMI-ANILINE LEATHER

Luxurious soft and silky touch dyed through, enhanced with oils and waxes and very lightly pigmented top grade cow hide. Suitable for medium to light wear situations which develops a rich character and patina over time. Scars, wrinkles and variations in grain and colour are endorsements of its natural beauty.

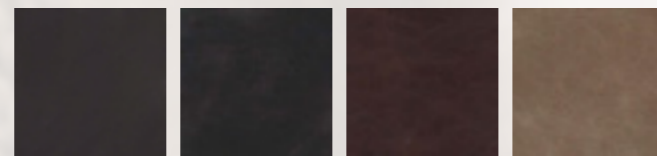

COFFEE COGNAC GRAPE LATTE

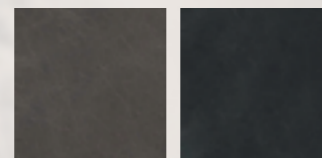

SCHIST ZAMBUCCA

NAPOLI PIGMENTED TOP-COATED LEATHERS

This leather is dyed and pigmented cow hide that shows a uniform grain and colour. Because it is more thoroughly treated than some 'natural' leathers it is much more practical. Layer on layer of pigment is at the root of this added wearability. Napoli is leather you can trust for those times when you need a more durable choice.

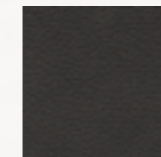

JAMAICA

Available only while our current stock lasts

NATUR SEMI-ANILINE LEATHER

This leather is top grade full grain bovine hide that has been dyed through and then very lightly pigmented. The light, protective top coat provides medium resistance to fade and colour loss. There is some resistance to soiling and spills but care should be taken not to choose 'Natur' for high risk wear situations.

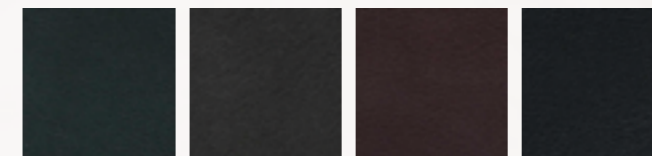

ANISEED CHOCOLATTO FUSO NERO

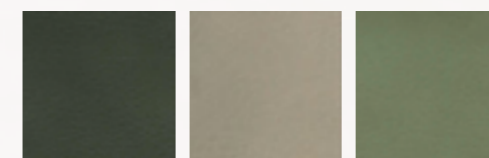

OLIVIO PALERMO PISTACHIO

Due to the printing process actual product colours may vary from colours shown here.

WOOD.

OUR SOLID WOOD LEGS ARE POLISHED TO A SATIN FINISH AND ARE AVAILABLE IN SIX STANDARD COLOURS.



NATURAL BIRCH HONEY

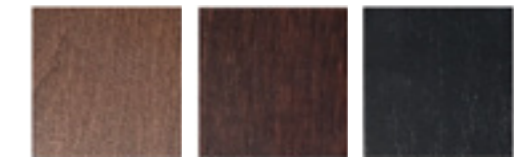

HICKORY CHOCOLATE WENGE





JED WIDE ARM SETTEE, SPYDER CHAIR
AND A HUMPTY OTTOMAN

INDEX

10 LOUNGE

10	Axle	(8-9)
10	Brooklyn	(11)
11	Club	
12	Dakota	(44-45)
12	Gibbston	(6-7)
12	Grace	(13)
13	Groovy	(14-15)
16	Heath	(56-57, 72)
16	Henley	(74-75)
16	Intrigue	(68-69)
17	Jed	(86-87)
17	Jigsaw	
17	Lincoln	
22	Loft	(18-19)
22	Lynx	
22	Marlow	(20-21)
23	Maverick	
23	Max	
23	Shabby Duke	(back cover)
26	Sienna	
26	Simplicity	(24-25, 91)

32 MODULAR LOUNGE

33	Bronte	(32)
34	Detroit	(4-5, 54)
35	Elements	(28-29)
36	Elton	(front cover, 2-3, 27)
37	Lennox	(30-31)
38	Morgan	(40-41, 70)
39	Newport	39
43	QBE	(42-43)

47 CHAIRS

47	Austin	(13)
47	Baxter	(44-45)
48	Diesel	(46, 57)
49	Frankie	(48)
49	Franklin	(48)
49	Louis	(75)
51	Luigi	
51	Malta	(9, 69)
51	Mantis	(19, 50)
52	Monte Largo	
52	Nero	
52	Roma	(79)
53	Spyder	(40, 87)
53	Tango	(54)
53	Taylor	
55	Verdi	
55	Zoe	

60 RECLINER LOUNGE

61	Euro	
61	Mercedes	
61	Murray	(60)
62	Ohau	
62	Ranfurly	(58-59)
62	Seddon	

63 PUREMOTION

66	Adele	(6-7)
66	Ella	(64-65)
66	Kiri	(67)
67	Nicole	(63)

70 HARD FURNITURE

71	Como Commodes	
71	Humpty	
71	Mason Tables	(8-9, 15, 19, 20, 25, 27, 40, 70)
72	Park-A Tables	(29, 35, 56-57, 68-69, 74)

73 AMALFI

76 OTTOMANS 76

77	Brooklyn	
77	Dumpty	(30, 56)
77	Humpty	(86)
77	Jed	(76)
77	Lacrosse	(79)
77	Morgan	
78	Newport	
78	Ranfurly	
78	Zoe	
78	OT1 Oblong	
78	OT2 Oblong - shallow	
78	OT3 Square	
78	OT3 Square - shallow	
78	OT5 Cuba Oblong	
78	OT6 Cuba Square	
78	OT7 Cowhide Square	
78	OT11 Enzo Round	(74-75)

KOVACS STOCKISTS IN NEW ZEALAND

NORTH ISLAND

Auckland

ALLIUM INTERIORS
11 Teed Street
Newmarket
phone: 09 524 4242
email: info@alliuminteriors.co.nz
alliuminteriors.co.nz

AMAZING INTERIORS

3/78 Picton Street
Howick
phone: 09 576 8190
mobile: 021 669 931
email: carol@amazinginteriors.co.nz
amazinginteriors.co.nz

MCGREALS FURNITURE

369 Khyber Pass Road
Newmarket
phone: 09 307 5290
email: sales@mcgreal.co.nz
mcgreal.co.nz

TOBEN HOME & DECOR

16D Link Drive
Wairau Park
phone: 09 913 3266
email: info@toben.co.nz
toben.co.nz

Waikato

THE DESIGN DEPOT
52 Alexandra Street,
Hamilton
phone: 07 839 6757
email: office@thedesigndepot.co.nz
thedesigndepot.co.nz

TURTON OLIVER

6 Sapper Moore-Jones Place
Hamilton
phone: 07 855 5247
email: info@turtonoliver.co.nz
turtonoliver.co.nz

INTERIORS BY FORMA

530 River Road
Hamilton
phone: 07 854 9495
mobile: 021 243 1241
email: darren@interiorsbyforma.co.nz
interiorsbyforma.co.nz

CURTAIN CREATIONS LIMITED

17/19 Rawhiti Avenue
Matamata
phone: 07 888 5414
mobile: 027 590 1924
email: alexis@curtaincreations.co.nz
curtaincreations.co.nz

Bay of Plenty

THE DESIGN DEPOT
13 Totara Street
Mt Maunganui
Tauranga
phone: 07 572 0215
email: office@thedesigndepot.co.nz
thedesigndepot.co.nz

FLORENCE & CO

55 Ninth Avenue
Tauranga
phone: 07 281 1409
email: info@florencandco.com
florencandco.com

Hawke's Bay

BRYAN HUTCHINSON LTD
226 - 232 Heretaunga Street East
Hastings
phone: 06 878 2144
email: sales@hutchinsons.net.nz
hutchinsons.net.nz

Taranaki

CLEGG'S FURNITURE COURT
181 Devon Street East
Strandon
New Plymouth
phone: 06 759 5690
email: gavin@cleggs.co.nz
cleggs.co.nz

Whanganui / Manawatu

KING & TEPPELT DESIGN
723 Main Street
Palmerston North
phone: 06 358 5589
email: info@kingandteppelt.co.nz
kingandteppelt.co.nz

EMMA BROWN DESIGN

33 George Street
Palmerston North
phone: 021 721 410
email: emma@emmabrown.co.nz
emma@emmabrown.co.nz

PETER ANDREWS FURNISHERS

35 Kimbolton Road
Fielding
phone: 06 323 3195
email: pg.andrews@xtra.co.nz
peterandrewsfurnishers.co.nz

WANGANUI FURNISHERS

33 Victoria Avenue
Bridge Block
Whanganui
phone: 06 345 4554
email: wangafurn@xtra.co.nz
wanganuifurnishers.co.nz

Wairarapa

COUNTRY LIFE FURNITURE
431 Queen Street
Masterton
phone: 06 378 6060
email: info@countrylife.co.nz
countrylife.co.nz

Wellington

LEWIS'S
25 Centennial Highway
Ngauranga
phone: 04 472 7722
email: wellington@lewiss.co.nz
lewiss.co.nz

MCKENZIE & WILLIS

153 Thorndon Quay
Pipitea
phone: 04 595 4250
email: wellington@mcw.nz
mcw.co.nz

PAULAS HOME & LIVING

25 Epiha Street
Paraparaumu
phone: 04 298 5990
email: info@paulas.co.nz
paulas.co.nz

DRESS MY NEST

22 Marine Parade
Paraparaumu Beach
phone: 027 566 5599
email: hello@dressmynest.co.nz
dressmynest.co.nz

SOUTH ISLAND

Nelson / Marlborough

LYNFORDS
43 Scott Street
Blenheim
phone: 03 577 9506
email: info@lynfords.co.nz
lynfords.co.nz

LYNFORDS
675a Main Road
Stoke, Nelson
phone: 03 547 9842
email: info@lynfords.co.nz
lynfords.co.nz

Canterbury

GLOBAL LIVING
100 Moorhouse Avenue
Addington, Christchurch
phone: 03 366 8480
email: relax@global-living.co.nz
global-living.co.nz

MCKENZIE & WILLIS CHRISTCHURCH

181 Blenheim Road
Riccarton, Christchurch
phone: 0800 888999
email: enquiry@mcw.nz
mcw.co.nz

TILLMANS FINE FURNITURE

146 Somerfield Street
Beckenham, Christchurch
phone: 03 366 2409
email: info@tillmans.co.nz
tillmans.co.nz

CASUAL AND COUNTRY HOMESTORE

1027 Ferry Road
Ferrymead, Christchurch
phone: 03 384 4880
email: store@casualandcountry.co.nz
casualandcountry.co.nz

REDMONDS
174 Burnett Street
Ashburton
phone: 03 308 5269
email: furnishing@redmonds.co.nz
redmonds.co.nz

LIVING WITH STYLE

29 Sophia Street
Timaru
phone: 03 688 2960
email: info@livingwithstyle.co.nz
livingwithstyle.co.nz

MCKENZIE & WILLIS TIMARU

The Old Post Office Building
16 Sophia Street
Timaru
phone: 03 684 7056
email: timaru@mcw.nz
mcw.co.nz

Otago

IVAN BULLING
195 Hanover Street
Dunedin
phone: 03 477 3323
email: dn@bullings.co.nz
bullings.co.nz

MCKENZIE & WILLIS DUNEDIN

97 Crawford Street
Dunedin
phone: 03 471 9100
email: dunedin@mcw.nz
mcw.co.nz

H&J SMITH FRANKTON

Remarkables Park Shopping Centre
Frankton, Queenstown
phone: 03 450 9270
email: reception@hjsmith.co.nz
hjsmith.co.nz

MCKENZIE & WILLIS QUEENSTOWN

The Junction - 54 Gorge Road
Queenstown
phone: 03 442 7355
email: queenstown@mcw.nz
mcw.co.nz

MCKENZIE & WILLIS WANAKA

20 Ardmore Street
Wanaka
phone: 03 443 4997
email: wanaka@mcw.nz
mcw.co.nz

Southland

H&J SMITH INVERCARGILL
66 - 74 Tay Street
Invercargill
phone: 03 211 0199
email: reception@hjsmith.co.nz
hjsmith.co.nz

IVAN BULLING

45 Tay Street
Invercargill
phone: 03 218 4579
email: furniture@bullings.co.nz
bullings.co.nz

*Please check our website
for the latest list of current
stockists.*

KOVACS.CO.NZ

MADE. RIGHT. HERE.



OUR HISTORY

KOVACS BEGAN IN 1959 IN CHRISTCHURCH, NEW ZEALAND UNDER THE CAREFUL GUIDANCE OF STEPHEN KOVACS.

With each new era the family business has passed down the skill within traditional European artisanship along with an unwavering commitment to innovation.

Despite changes in style our focus, accuracy and adherence to these standards has resulted in the consistent development of distinctive luxury furniture. Our close supplier relationships, carefully forged over these years, have come with sourcing our materials from companies that parallel our devotion to the craft.

The popularity of the Kovacs brand has grown with each generation and, as discerning consumers recognise the difference investing in true luxury provides, it will continue to do so. That difference? The most comfortable, durable and timelessly stylish furniture you'll own. From our factory, to your homes and businesses, our furniture is still made here – and still true to you.

KOVACS.CO.NZ



SIMPLICITY CHAIR

KOVACS

DESIGN FURNITURE



VOLUME 03