



ART COCKPIT Assembly Guide

Recommended
1-2 People



Read Instructions
10 Minutes

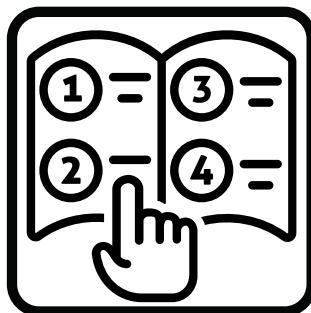

Assembly Time
30 Minutes

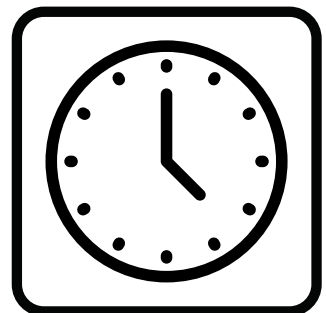

gtomega.com

TABLE OF CONTENT

PAGE 1

NOTICES

PAGE 2

WHAT'S IN THE BOX

PAGE 3 - 10

ASSEMBLY INSTRUCTIONS

PAGE 11

ADJUSTABILITY GUIDE



Need Help? We're here for you! Contact our support team:

SCAN ME



Supportus@gtomega.com

*Handling times targeted at 24 hours.
Please allow time for a response*



(+44)141-370-6780

*Monday - Friday
9am - 4pm (Glasgow, Scotland)*

WARNING



Children
should not
use
unsupervised



Do not exceed
load capacity
of **200KG**



Do not stand
on the
Cockpit



Take care
when
assembling



Do not Push or
pull Cockpit
across the floor



FAILURE TO COMPLY WITH OR OBSERVE ALL ASSEMBLY, SAFETY, AND OPERATION INSTRUCTIONS REGARDING THE USE OF THIS PRODUCT MAY RESULT IN **PROPERTY DAMAGE** OR **BODILY INJURY**.

- This document contains important safety regulations. Any non-conforming use may result in personal injury or mechanical damage.
- Please read this user manual carefully before use as it provides key information about safety, use, and assembly of the **ART Cockpit**.
- Ensure that you have received all parts according to the part checklist prior to installation. If any parts are missing or faulty, contact the GT Omega support team for replacements.
- **Do not** over tighten the screws during installation.
- This product contains small items that could be a choking hazard if swallowed. Keep these items away from children.
- This product is designed for indoor use only. Using the product outdoors could lead to product failure and personal injury.
- Alteration or modification of any factory components outlined in the checklist will automatically void your warranty.
- Place the **ART Cockpit** away from corrosive gas, water and dusty environments.

The **ART Cockpit** is designed for indoor use and dry work areas only. Under no circumstances does the manufacturer accept warranty claims or liability claims for damages caused from improper use or handling.

WHAT'S IN THE BOX

A. 6x M6x40 Bolts

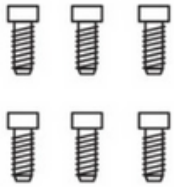

B. 6x Hand Screws

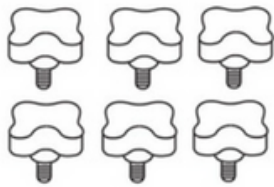

C. 8x Rubber Feet

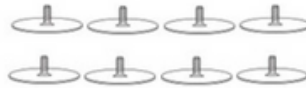

D. 2x M8x80 Half-Threaded Bolts



E. 8x M8x16 Hex Bolts

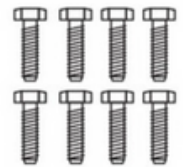

F. 1x Metal Spacer



G. 14x Washers



H. 8x M8x35 Bolts

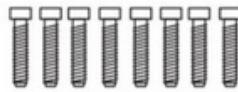

I. 4x Flange Nuts



J. 2x Allen Keys

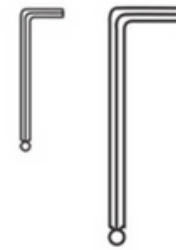

K. 1x Spanner



L. 4x Velcro Straps



M. 2x M6x16 Bolts



N. 8x M8 Nuts

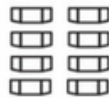

O. 6x M8 Square Nuts

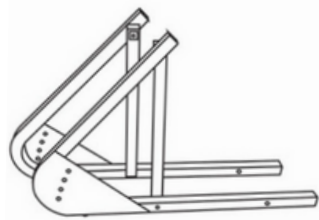

1. Front Frames

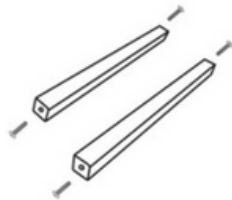

2. Centre Bars

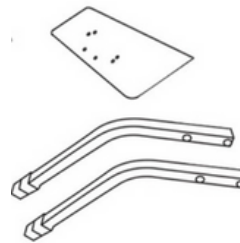

3. Wheel Deck + Supports

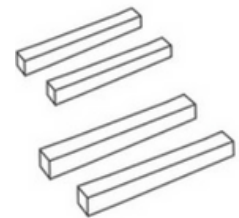

4. Extension Bars

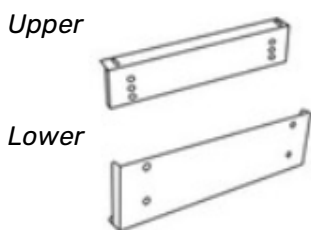

5. Seat Mounts x2

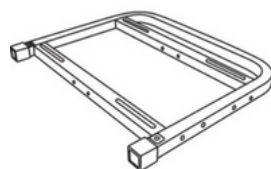

6. Rear Frame

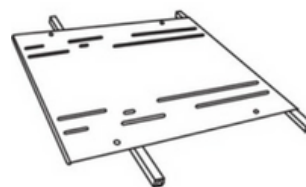

7. Pedal Tray

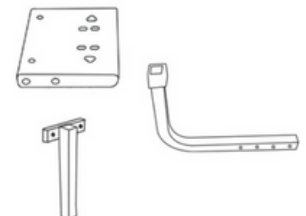

8. Gear Shifter Mount

ASSEMBLY INSTRUCTIONS

1 Assemble Front Section

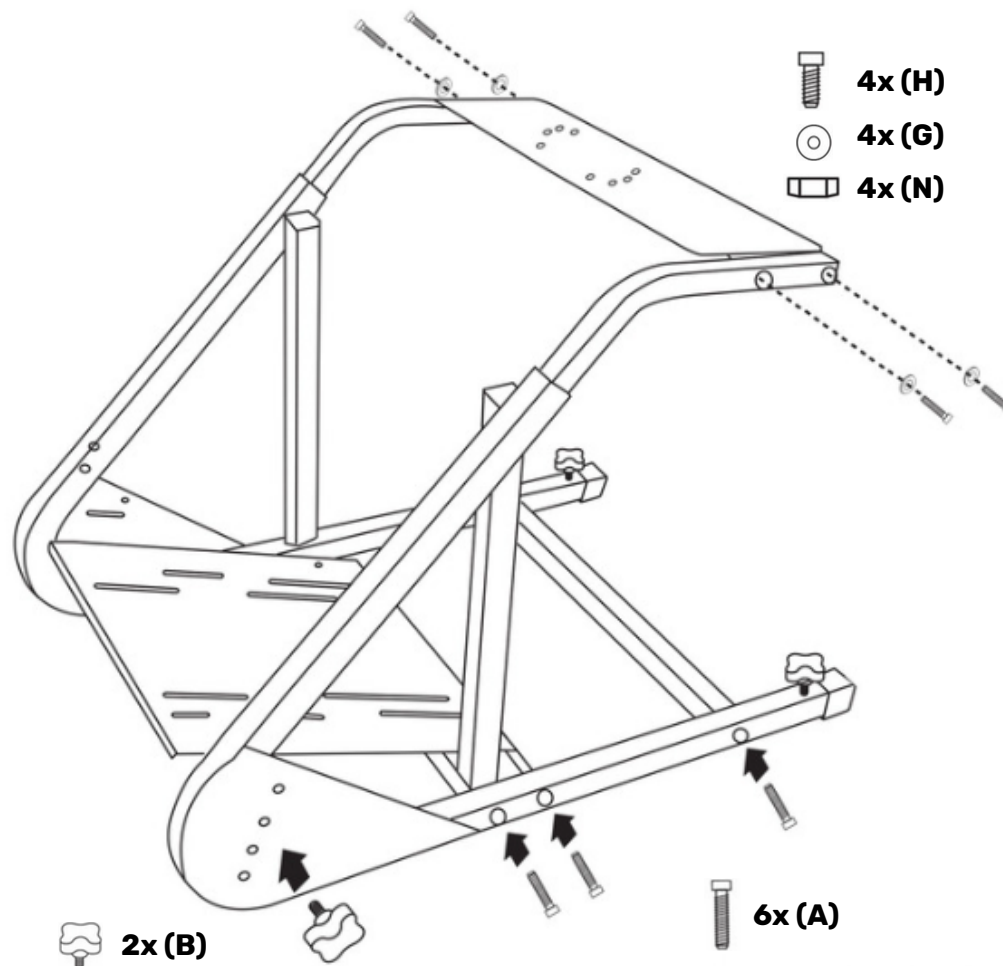

a Insert the wheel deck supports into the front frame as shown then bolt the wheel deck into position.

b Line up the Pedal Tray and bolt into place.

! Avoid over-tightening screws. As this may damage the product.

ASSEMBLY INSTRUCTIONS

2 Assemble Rear Section

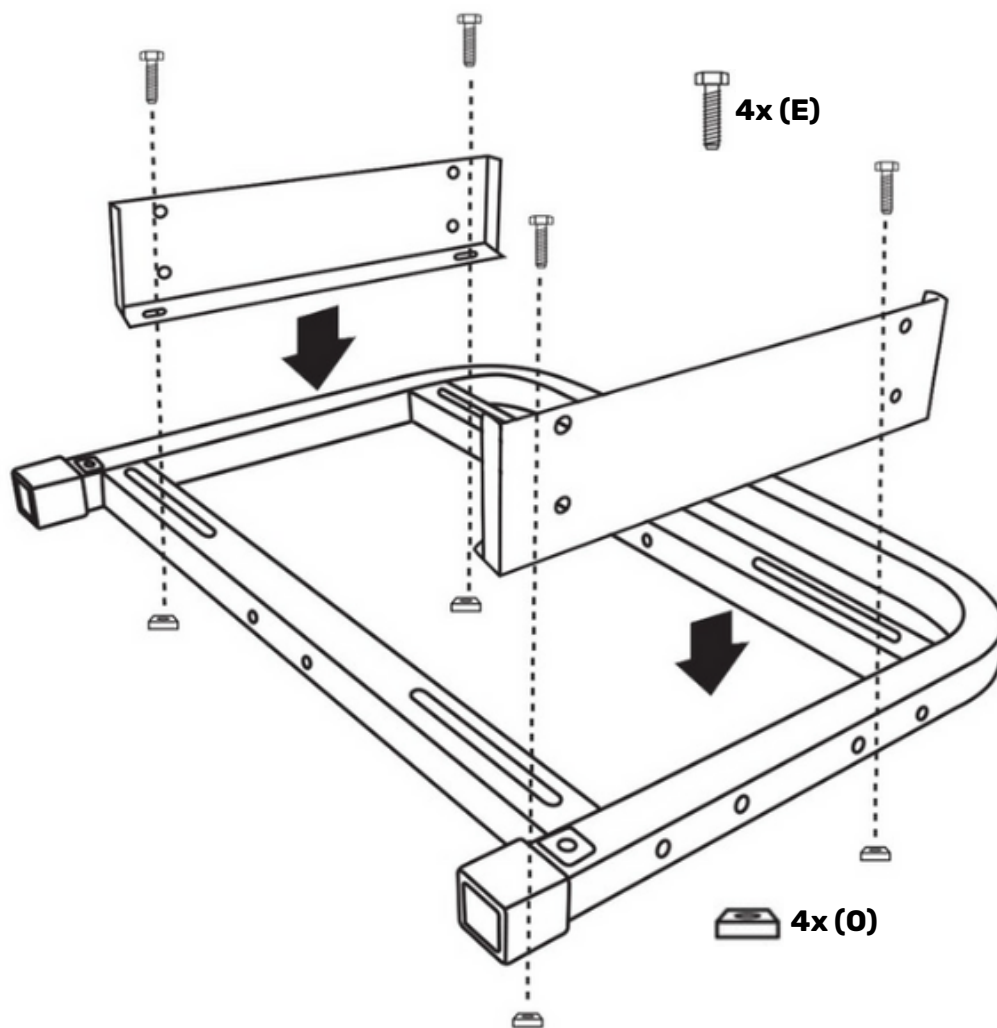

- a** Connect lower seat mount sections to rear frame. **Keep loosely fitted** to allow for easy adjustment when mounting seat.

! Avoid over-tightening screws. As this may damage the product.

ASSEMBLY INSTRUCTIONS

3 Mount Racing Seat

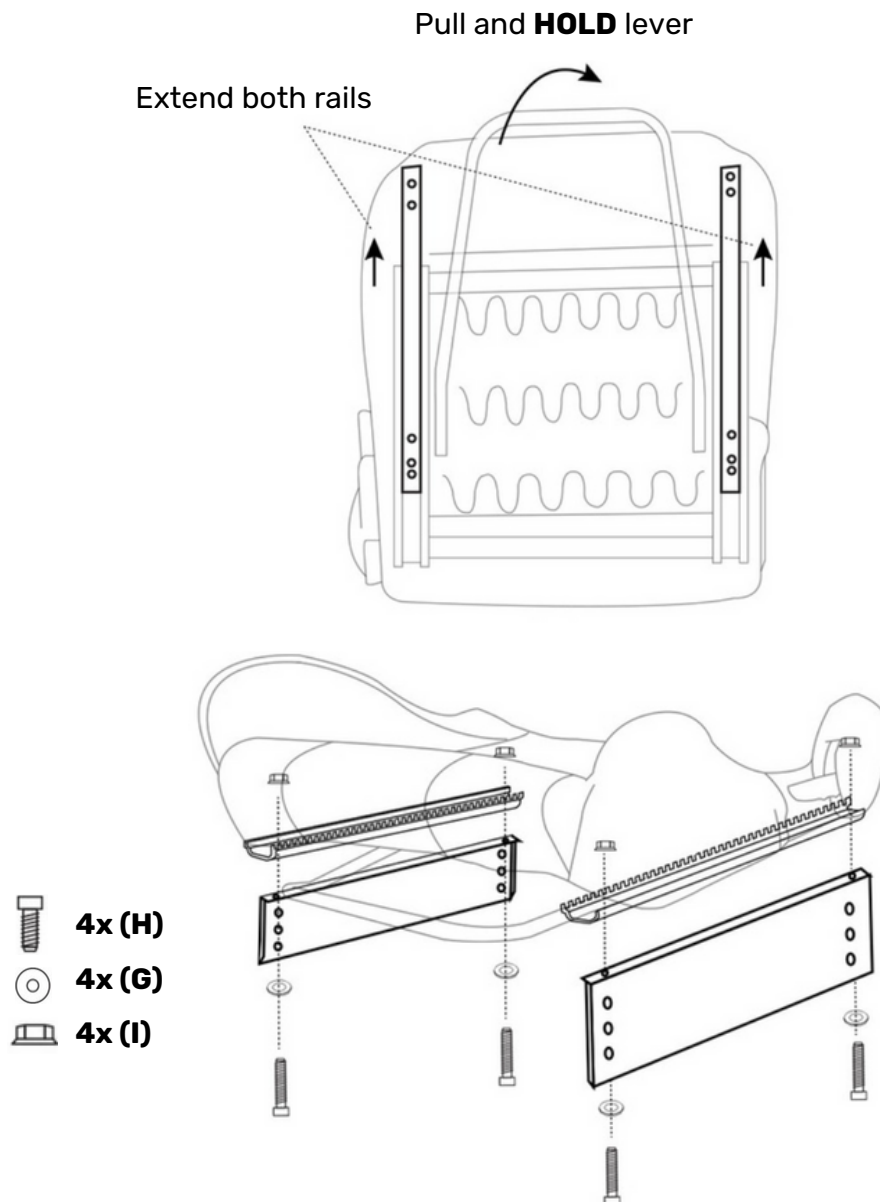

- a** Pull the seat lever to allow you to extend the seat rails.
- b** Bolt the upper sections of the seat mount to the seat rails. Adjust rails as needed to access rear bolt holes.

! Avoid over-tightening screws. As this may damage the product.

ASSEMBLY INSTRUCTIONS

3 Mount Racing Seat (*continued*)

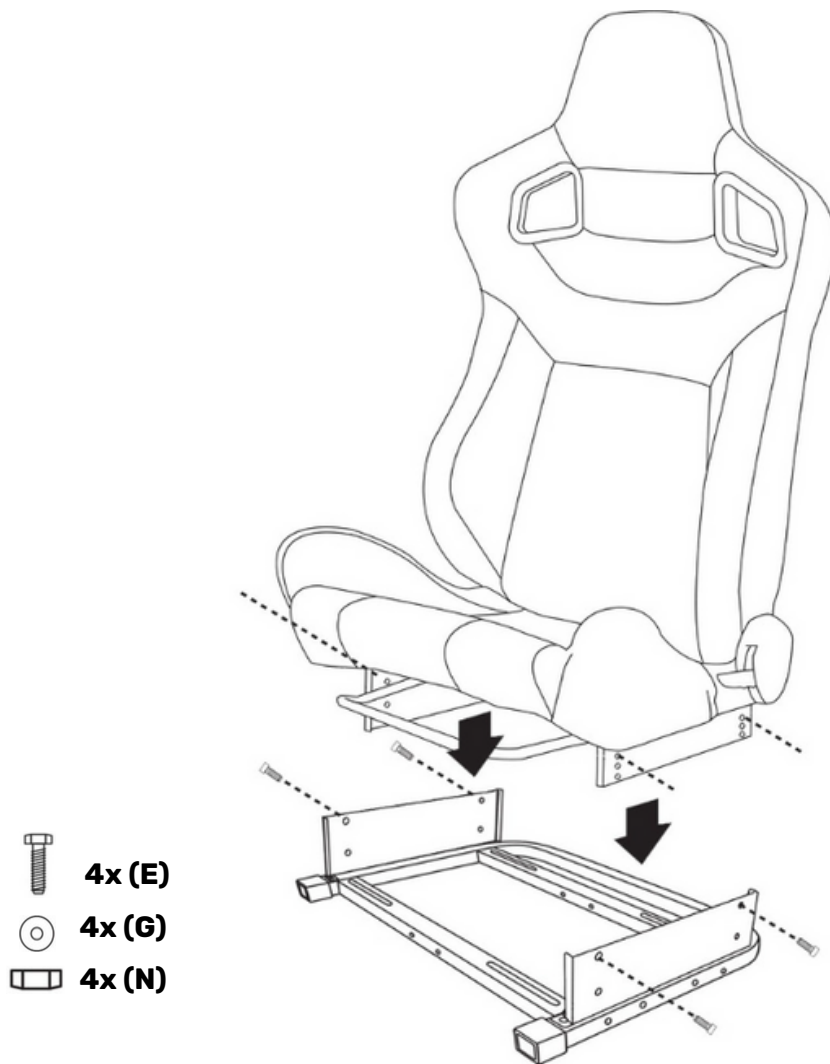

- a** Connect the upper and lower sections of your seat mount. Once fitted, centre the seat and mounts **then tighten all the nuts and bolts.**



Installation guide is for **GT Omega** racing seats. If you are using something else the process may be different.



Avoid over-tightening screws. As this may damage the product.

ASSEMBLY INSTRUCTIONS

4 Connect Front and Rear Sections

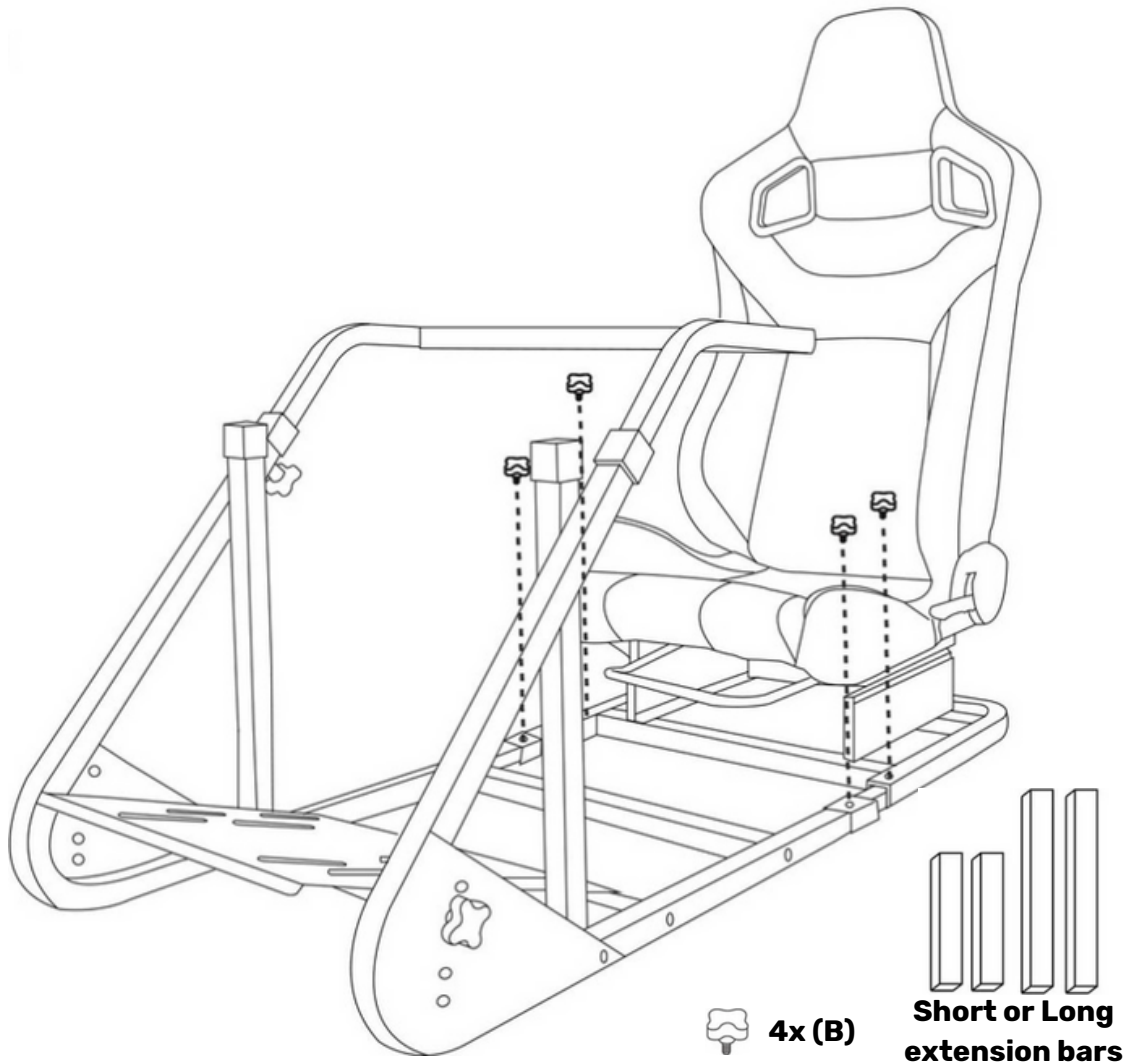

- a** Using a set of the extension bars, connect the front and rear sections and then secure using the hand screw bolts provided.



Longer extension bars are better for users with longer legs. It's easy to swap out the sets to adjust for users of different sizes!



Avoid over-tightening screws. As this may damage the product.

ASSEMBLY INSTRUCTIONS

5 Connect Gear Shifter Mount

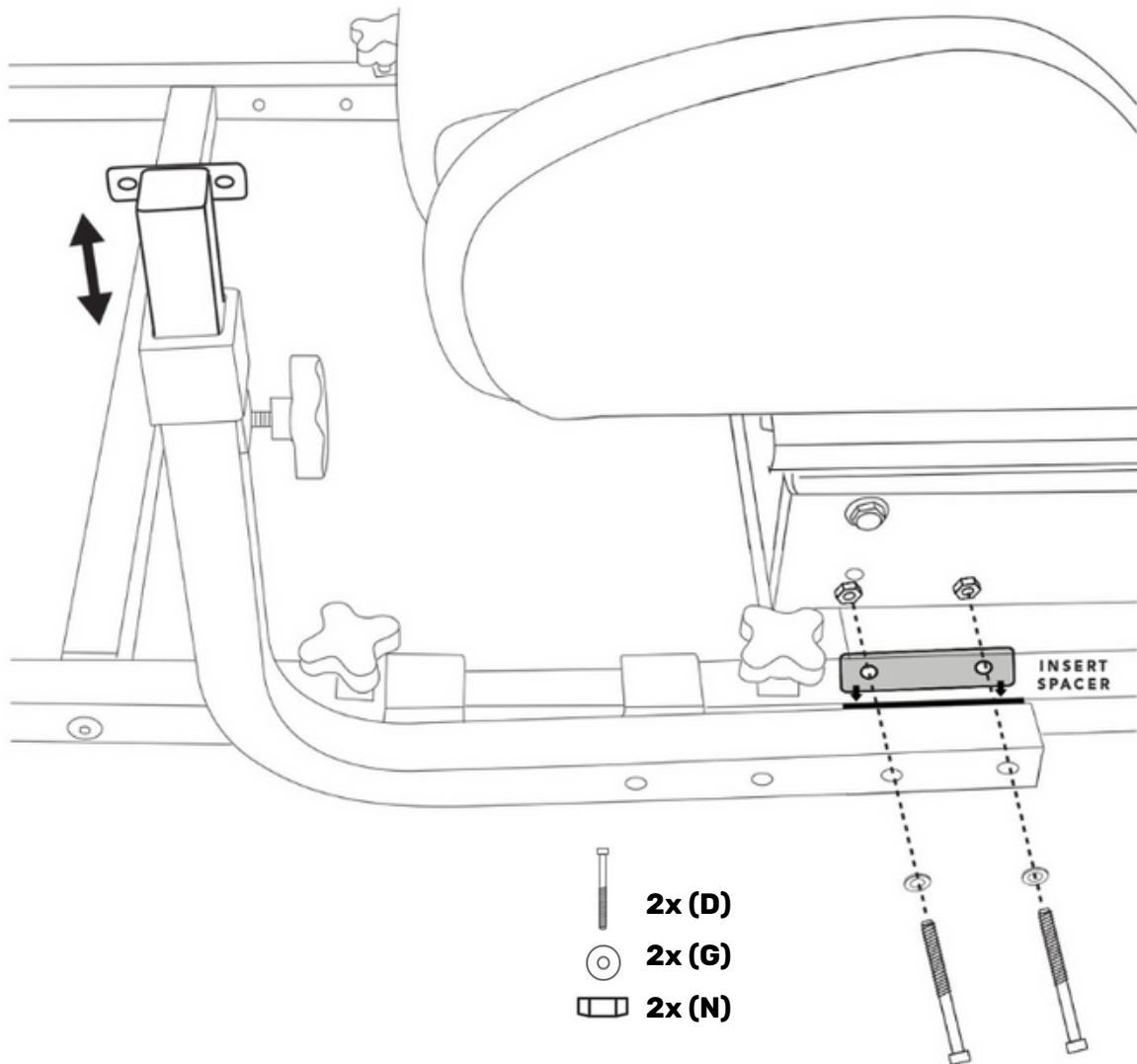

a Connect the gear shifter mount as shown. **Bolt securely.**



The gear shifter mount can be mounted further back or on the left or right side to suit your preference.

! Avoid over-tightening screws. As this may damage the product.

ASSEMBLY INSTRUCTIONS

5 Connect Gear Shifter Mount *(continued)*

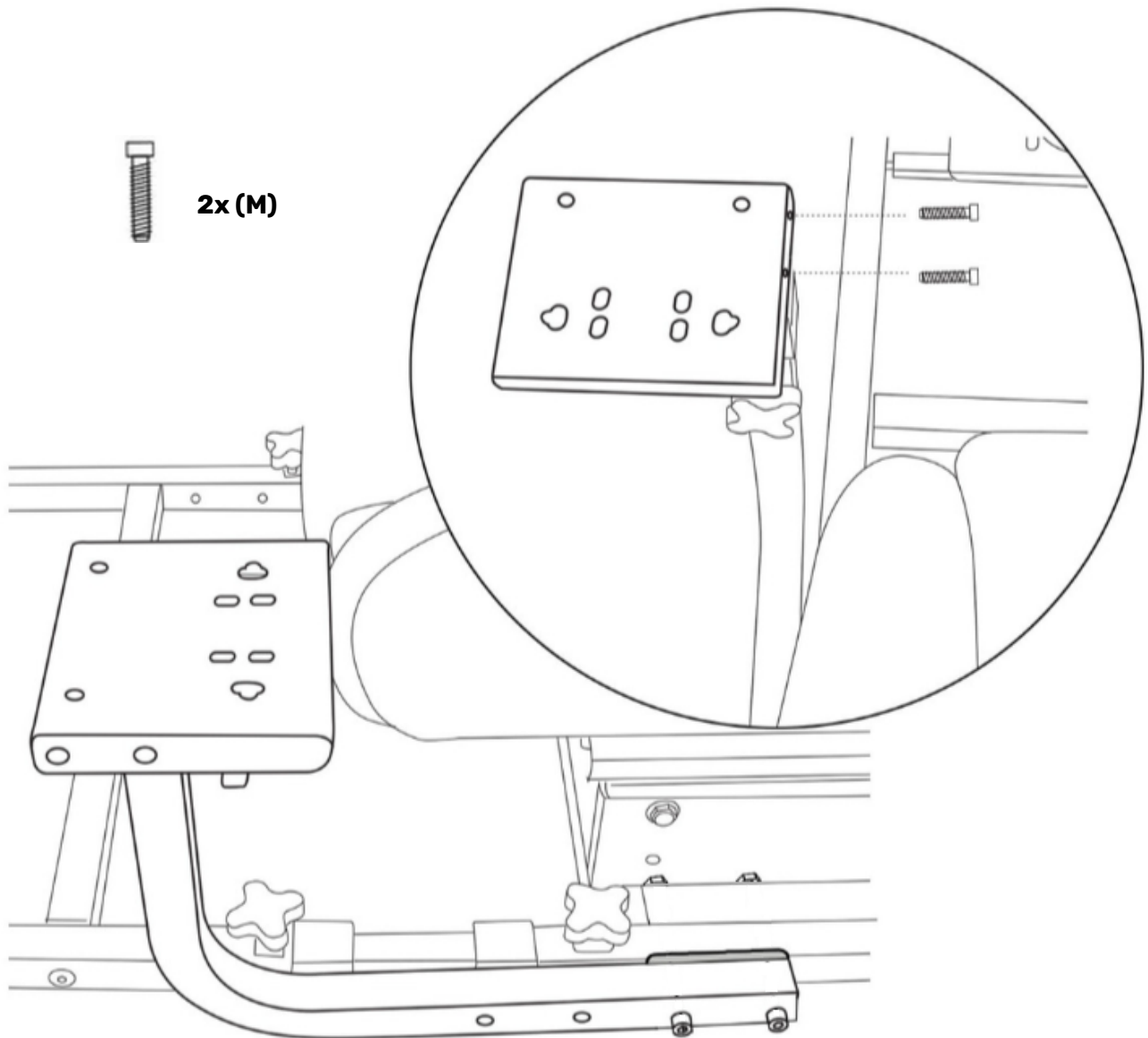

a Bolt the gear shifter plate firmly into place.

! Avoid over-tightening screws. As this may damage the product.

ASSEMBLY INSTRUCTIONS

6 Connect Feet to Cockpit

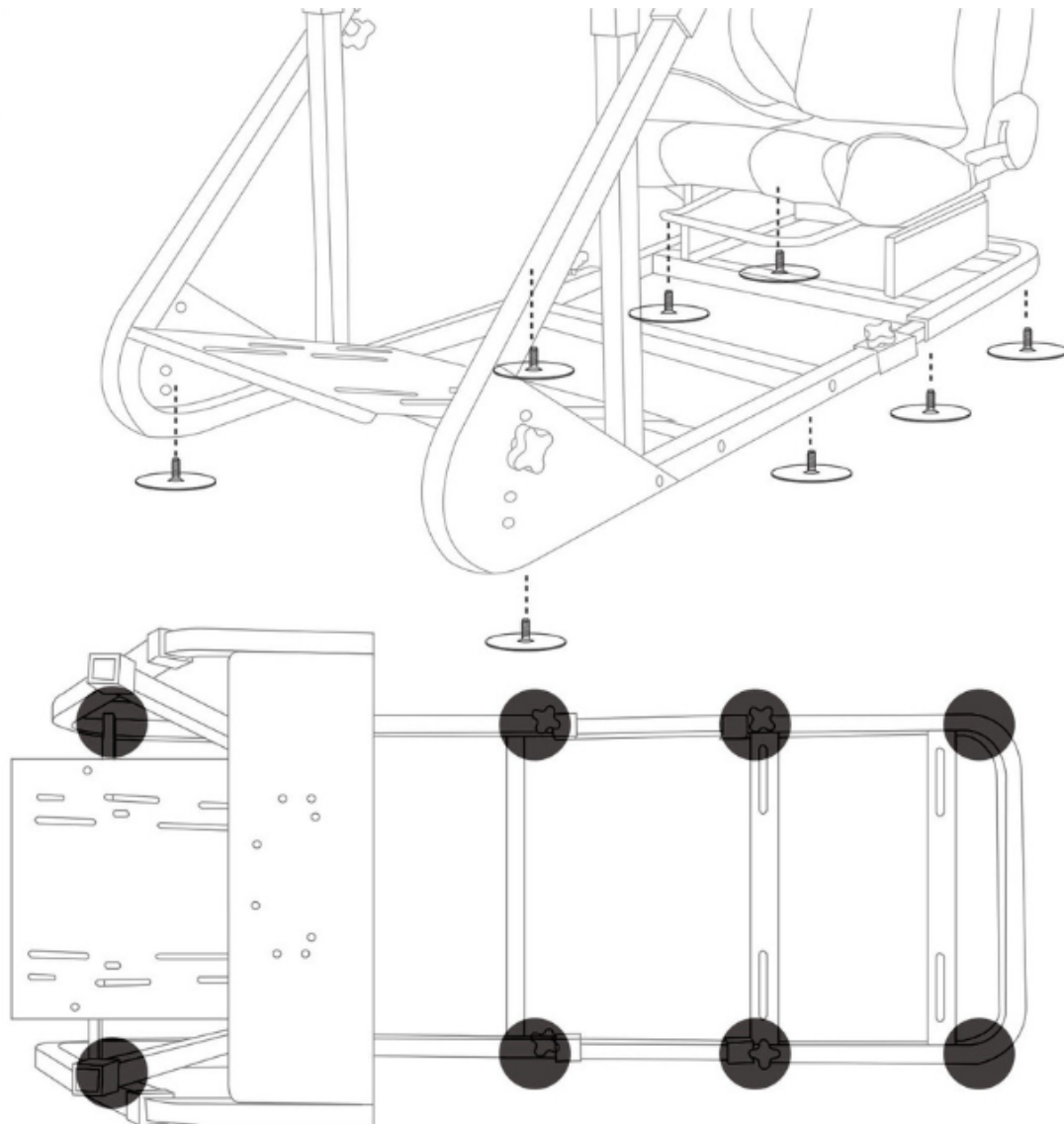

- a** Carefully turn the cockpit the cockpit on its side and screw in the feet.



The **ART Cockpit** feet are adjustable in height making them able to provide a stable experience on uneven floors.

- !** Avoid over-tightening screws. As this may damage the product.

ADJUSTMENT GUIDE

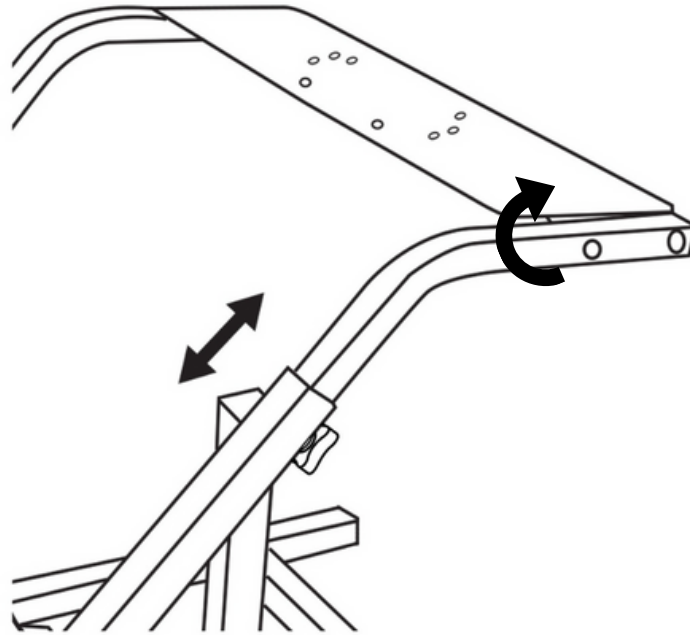

- a** Loosen hand screws on both sides to change wheel deck height.
- b** Loosen bolts on the wheel deck to adjust wheel deck angle.

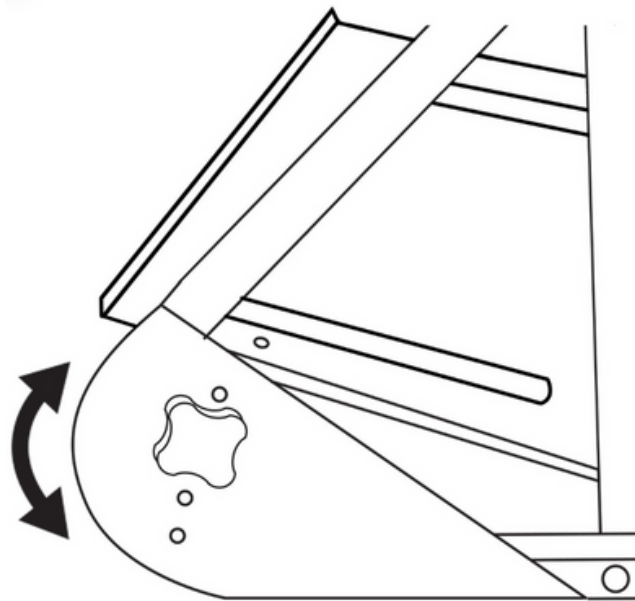

- c** Loosen hand screws on both sides to adjust pedal plate angle.

Unlock the full potential of your ART COCKPIT



Support Bars

Redistribute weight and torque more evenly across your ART Cockpit, reducing flex and providing a more consistent and rewarding racing experience.

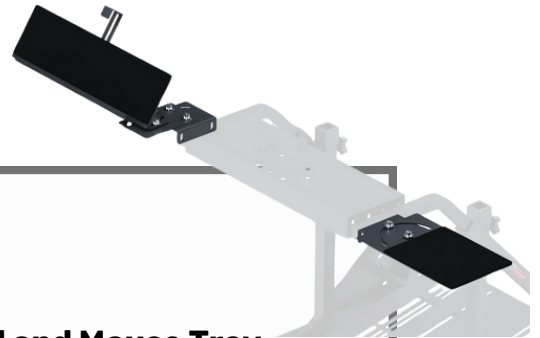

Keyboard and Mouse Tray

Stay in control without ever having to leave your seat. The non-slip rubber coating ensures that your keyboard and mouse will stay firmly planted while you play.



ART Single Monitor Mount

Practical and convenient: This **essential** upgrade completes your ART Cockpit and is fully adjustable to suit your needs!



To see these products and more,
visit us at gtomega.com 