

# SwiftAir

MVHR | CONTROL SYSTEM

USER MANUAL | ENGLISH VERSION OV1.2

INSTALLATION INSTRUCTION & OPERATION GUIDE

CONTROL PANEL MODEL VK2



## **ACCESSORIES**

External Boost Switch Model EBS-01

External Boost Connection Box Model EBCB-01

External Electrical Heater Model EEH-01

External Electrical Air Damper Model EEAD-01

External Relay Board Model ERB-01

### **External Boost Switch**

- External Boost Switch is not included in the delivery set (available as accessories for purchase)
- Up to 10 external boost switches can be connected to the control system via the connection board

### **External Boost Connection Box**

- External Boost Connection Box is not included in the delivery set (available as accessories for purchase)
- External Boost Connection Board
- Connecting external boost switches to the control system

### **External Electrical Heater**

- External Electrical Heater is not included in the delivery set (available as accessories for purchase)
- Up to 2 external electrical heaters can be connected to the control system via the relay board

### **External Electrical Air Damper**

- External Electrical Air Damper is not included in the delivery set (available as accessories for purchase)
- Up to 2 external electrical air dampers can be connected to the control system via the relay board

### **External Relay Board**

- External Relay Board is not included in the delivery set (available as accessories for purchase)
- Connecting external air dampers and external heaters to the control system

## 01/ CONTROL PANEL & ACCESSORIES INSTALLATION INSTRUCTION

- Before installing or maintaining the system, main power must be turned OFF to avoid personal injury due to electric shock
- Wiring should be strictly in accordance with the cable configuration requirements
- Protective measures must be taken to prevent the ventilation system failure, risk of electric shock and fire
- Below diagrams and tables illustrate the connection of the power and the control system
- Go to **TERMINAL BLOCK T1-A1** and **T2-D1** for the quick connection method of the standard model

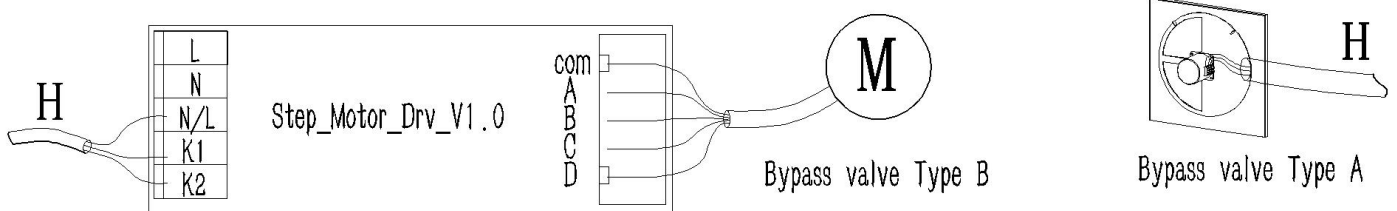
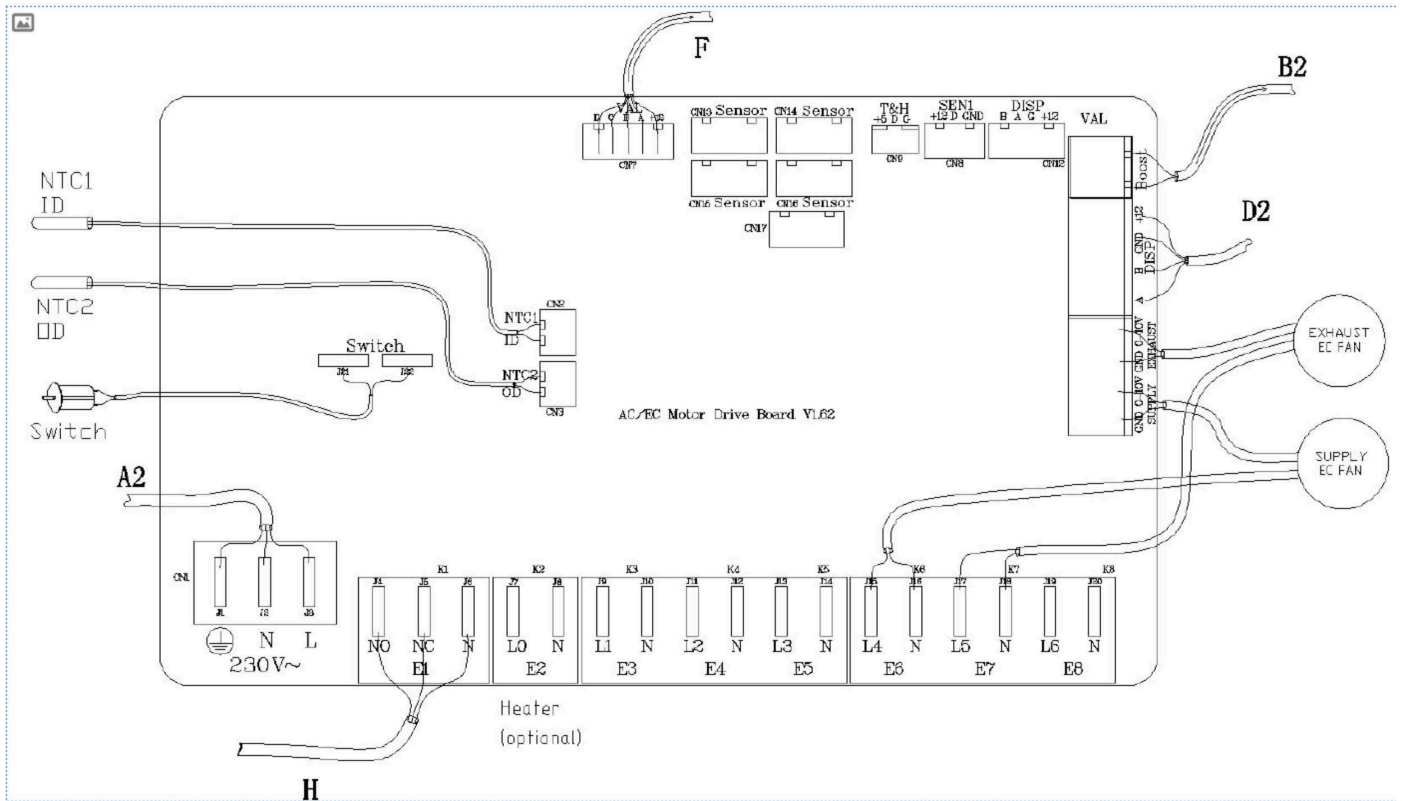

### AC/EC MOTOR DRIVE BOARD

A2	GND	→ Connect to Terminal Block [T1-A2] [GND]
	N	→ Connect to Terminal Block [T1-A2] [N]
	L	→ Connect to Terminal Block [T1-A2] [L]
E1	NO	Cable H
	NC	→ Connect to Bypass Valve
	N	For MVHR Series C / Series CS / Series W / Series TP Model
E2	LO	→ Connect to Internal Electrical Heater (optional)
	N	
[E3] [E4] [E5] Reserve		

E6	L4	Supply Fan Power Supply Connection
	N	
E7	L5	Extract Fan Power Supply Connection
	N	
[E8] Reserve		
[Supply] [GND] [0-10V] EC Supply Fan Speed Control		
[Exhaust] [GND] [0-10V] EC Extract Fan Speed Control		
D2	[+12]	→ Connect to Terminal Block [T2-D2] [DISP] [12V]
	GND	→ Connect to Terminal Block [T2-D2] [DISP] [G]
	B	→ Connect to Terminal Block [T2-D2] [DISP] [B]
	A	→ Connect to Terminal Block [T2-D2] [DISP] [A]
B2	Boost	→ Connect to Terminal Block [T2-B2] [Boost] [X1] [X2]
[F] [CN7]		→ Connect to External Relay Board (model ERB-01) [F]
[CN8]		Jumper [D] [GND] for EC Motor Type
[CN9] [CN12] [CN13] [CN14] [CN15] [CN16] [CN17] Reserve		
NTC1 (ID)		Exhaust Air Temperature Sensor
NTC2 (OD)		Outdoor Air Temperature Sensor
Switch		Safety Switch For MVHR Series ES / Series CS / Series W Model

<b>Bypass Valve Type A</b>		
Motor [N]		← Connect from AC/EC Motor Drive Board [H-E1] [N]
Motor [NO]		Through a Micro Switch → Connect to AC/EC Motor Drive Board [H-E1] [NO]
Motor [NC]		Through a Micro Switch → Connect to AC/EC Motor Drive Board [H-E1] [NC]

<b>Bypass Valve Type B</b>		
L		← Connect from AC/EC Motor Drive Board [A2-CN1] [J3]
N		← Connect from AC/EC Motor Drive Board [A2-CN1] [J2]
N/L		← Connect from AC/EC Motor Drive Board [H-E1] [N]
K1		← Connect from AC/EC Motor Drive Board [H-E1] [NO]
K2		← Connect from AC/EC Motor Drive Board [H-E1] [NC]
[Com] [A] [B] [C] [D]		Plug Cable → Connect to Stepping Motor

To Unit External To Unit Internal

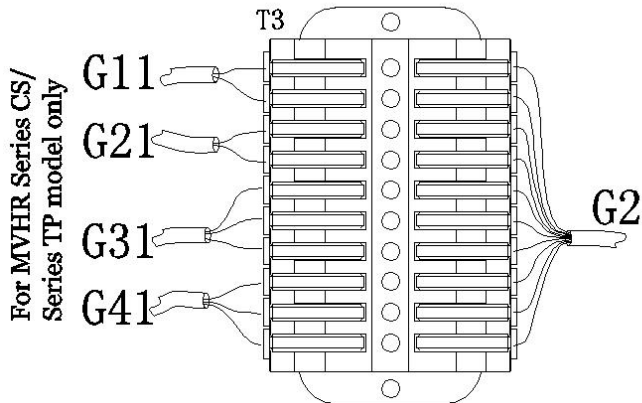

T3		
Dampers/Heater	NO12	GY
	COM12	WH
	NO11	GN
	COM11	BU
	NC10	BN
	NO10	BK
	N/OV	RD
	NC9	OG
	NO9	PU
	N/OV	YL

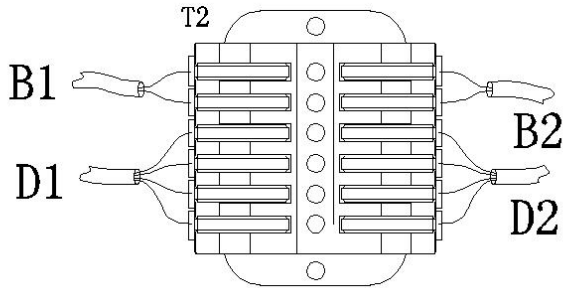

T2		
Boost	X1	GY
	X2	WH
DISP	12V	RD
	G	OG
	B	PU
	A	YL

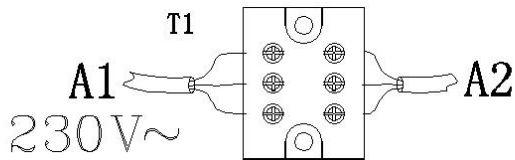

T1		
Power		YL/GN
	N	BU
	L	BN

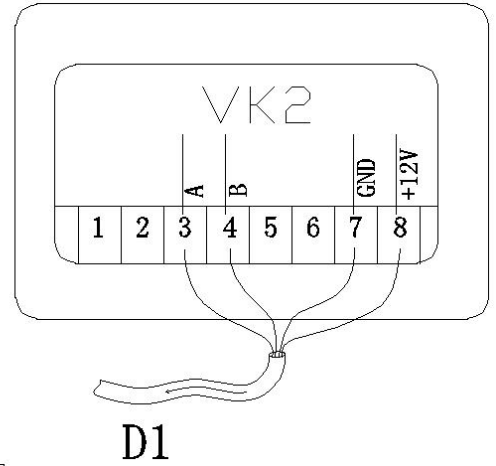

**TERMINAL BLOCK**

T1	A1	GND		→ Connect to Customer's Power Supply [GND]
		N		→ Connect to Customer's Power Supply [N]
		L		→ Connect to Customer's Power Supply [L]
T2	A2	GND	Color YL/GN	← Connect from AC/EC Motor Drive Board [A2] [CN1] [J1]
		N	Color BU	← Connect from AC/EC Motor Drive Board [A2] [CN1] [J2]
		L	Color BN	← Connect from AC/EC Motor Drive Board [A2] [CN1] [J3]
T2	B1	X1		→ Connect to External Boost Connection Board [B1] [X1] (optional)
		X2		→ Connect to External Boost Connection Board [B1] [X2] (optional)
	B2	X1	Color GY	← Connect from AC/EC Motor Drive Board [B2] [Boost] [X1] [X2]
		X2	Color WH	
	D1	12V	Color BN	→ Connect to VK2 Control Panel [+12V] [8]
		G	Color BU	→ Connect to VK2 Control Panel [GND] [7]
		B	Color BK	→ Connect to VK2 Control Panel [B] [4]
		A	Color GY	→ Connect to VK2 Control Panel [A] [3]
	D2	12V	Color RD	← Connect from AC/EC Motor Drive Board [D2] [+12] [DISP]
		G	Color OG	← Connect from AC/EC Motor Drive Board [D2] [GND] [DISP]
		B	Color PU	← Connect from AC/EC Motor Drive Board [D2] [B] [DISP]
		A	Color YL	← Connect from AC/EC Motor Drive Board [D2] [A] [DISP]
T3	G11	NO12		Reserve
		COM12		
	G21	NO11		→ Connect to External Electrical Heater Interlock (optional)
		COM11		

	G31	NC10		→ Connect to External Exhaust Air Damper - Close (optional)
		NO10		→ Connect to External Exhaust Air Damper - Open (optional)
		N/OV		→ Connect to External Exhaust Air Damper - Com. (optional)
	G41	NC9		→ Connect to External Intake Air Damper - Close (optional)
		NO9		→ Connect to External Intake Air Damper - Open (optional)
		N/OV		→ Connect to External Intake Air Damper - Com. (optional)
	G2	NO12	Color GY	← Connect from External Relay Board [K12] [NO12] (optional)
		COM12	Color WH	← Connect from External Relay Board [K12] [COM12] (optional)
		NO11	Color GN	← Connect from External Relay Board [K11] [NO11] (optional)
		COM11	Color BU	← Connect from External Relay Board [K11] [COM11] (optional)
		NC10	Color BN	← Connect from External Relay Board [K10] [NC10] (optional)
		NO10	Color BK	← Connect from External Relay Board [K10] [NO10] (optional)
N/OV		Color RD	← Connect from External Relay Board [K10] [N/OV] (optional)	
NC9		Color OG	← Connect from External Relay Board [K9] [NC9] (optional)	
NO9		Color PU	← Connect from External Relay Board [K9] [NO9] (optional)	
N/OV	Color YL	← Connect from External Relay Board [K9] [N/OV] (optional)		

VK2 Control Panel [D1]		
3	A	← Connect from Terminal Block [T2-D1] [A]
4	B	← Connect from Terminal Block [T2-D1] [B]
7	GND	← Connect from Terminal Block [T2-D1] [G]
8	12V	← Connect from Terminal Block [T2-D1] [12V]

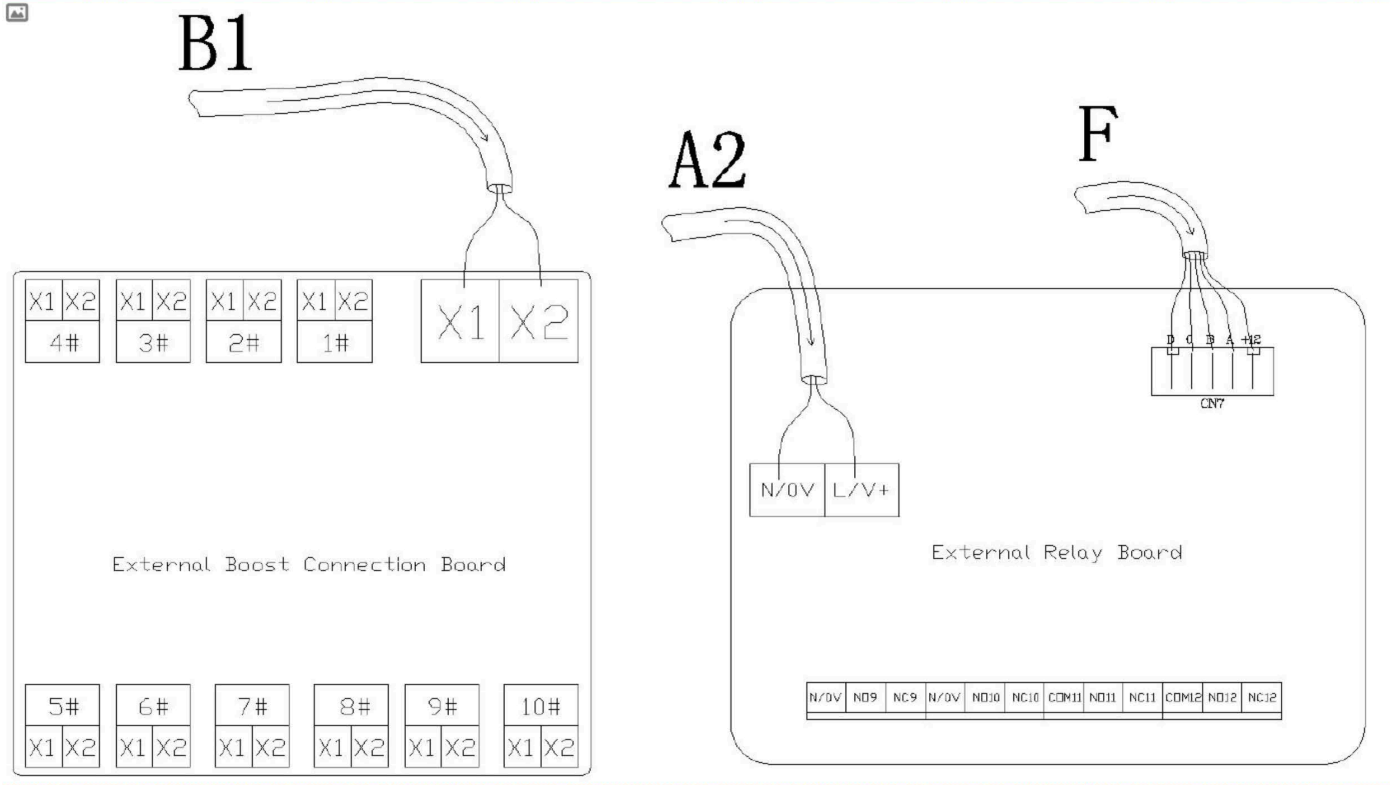

**EXTERNAL BOOST CONNECTION BOARD**

B1	X1	← Connect from Terminal Block [T2-B1] [Boost] [X1] (optional)
	X2	← Connect from Terminal Block [T2-B1] [Boost] [X2] (optional)
	[1#] - [10#] [X1]	→ Connect to External Boost Switch (model EBS-01) (optional)
	[1#] - [10#] [X2]	→ Connect to External Boost Switch (model EBS-01) (optional)

**EXTERNAL RELAY BOARD**









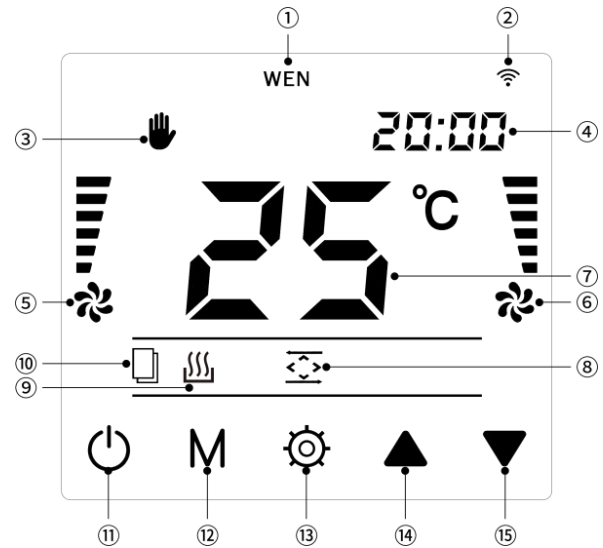





A2	N/0V	← Connect from AC/EC Motor Drive Board [A2-CN1] [J2] [J3]
	L/V+	
F	D	← Connect from AC/EC Motor Drive Board [F] [CN7]
	C	
	B	
	A	
	12V	
	[N/0V]	→ Connect to Terminal Block [T3-G2]
	[NO9] [NC9]	
	[N/0V]	
	[NO10] [NC10]	
	[COM11]	
	[NO11] [NC11]	
	[COM12]	
	[NO12] [NC12]	

## 02/ CONTROL PANEL OPERATION GUIDE



- Control Panel Model VK2 is not included in the delivery set (available as accessories for purchase)









- ① Current day indication
- ② Current WiFi connection status indication
- ③ Current operating mode indication
- ④ Current time indication
- ⑤ Current supply fan speed level indication
- ⑥ Current extract fan speed level indication
- ⑦ Current indoor temperature level indication
- ⑧ Current bypass function ON/OFF indication
- ⑨ Current electrical heater ON/OFF indication
- ⑩ Filter cleaning or replacement notification
- ⑪ Ventilation system control power ON/OFF switch key
- ⑫ Manual/Timer operating mode switch key
- ⑬ Timer parameter setting key
- ⑭ Parameter up key
- ⑮ Parameter down key



- Short press the  key to turn ON or OFF the ventilation system. When the ventilation system is OFF the screen only shows the  icon and the output is OFF
- Short press the  key to switch operating mode, the operating mode switches between manual mode and timer mode, the  icon displays in the manual mode, the  icon displays in the timer mode
- When the supply fan is operating, short press the  key to turn ON or OFF the electrical heater. After the supply fan stops operating, the electrical heater automatically turns OFF, the  icon displays when the electrical heater turns ON (heating function only available when heater installed)
- Short press the  key or the  key in timer mode to open or close the bypass damper manually, the  icon displays when the bypass damper opens, the  icon displays when the bypass damper closes, then switch the operating mode back into manual mode for normal operation (bypass function only available for MVHR SERIES C / SERIES CS / SERIES W / SERIES TP MODEL)
- In manual operating mode, short press the  key to adjust the supply fan speed level, short press the  key to adjust the extract fan speed level (bypass free-cooling can be realized by turning OFF the extract fan)
- Short press the  key and the  key at the same time to start the boost function within 2 seconds, the supply



fan and the extract fan run at the maximum fan speed level in boost mode, the two fan speed indicators flash rapidly during boost mode, the previous operation state restores after running for 20 minutes (by pressing the  key and the  key at the same time again during boost mode to stop the boost function)

- Defrost function automatically starts when the exhaust air (to outdoor) temperature sensor from the ventilation unit automatically detects the temperature at the heat exchanger, the ventilation system enters into the automatic defrost mode if the temperature detected is lower than  $-2^{\circ}\text{C}$ , defrost mode runs for 15 minutes (defrost mode operation interval is 45 minutes). The extract fan runs at the maximum fan speed level while the supply fan stops running in defrost mode, the extract fan speed indicator flashes slowly during defrost mode, the previous operation state restores after defrost function ends
- In manual mode, long press the  key to check the temperature of the exhaust air (to outdoor) at the heat exchanger, long press the  key to check the temperature of the intake air (from outdoor)
- Long press the  key for 2 seconds to enter into the timer parameter setting, first enter into the local time correction, short press the  key to switch the week, hour, and minute, the corresponding parameters then flash, and modify the values by pressing the  and  keys. After the local time correction, short press the **M** key to enter into the hour setting of Monday period 1, short press the  key to switch the hour, minute, and fan speed, and modify the values by pressing the  and  keys, after the settings completed, short press the **M** key to enter into the Monday period 2 to set....., repeat the previous steps until all settings of the 28 time periods completed. (If the keys are not operated for more than 10 seconds during the setting process, the controller will automatically return to the normal operating state and save the setting parameters). For example: set the Monday period 1 at 8:00 at fan speed level 1, period 2 at 9:00 at fan speed level 2, period 3 at 15:00 at fan speed level 3 and period 4 at 23:00 at fan speed level 0. When the current day is Monday, the ventilation system operates as follows: 0:00-7:59 runs at the fan speed at the last time period of the previous day, 8:00-8:59 runs at fan speed level 1, 9:00-14:59 runs at fan speed level 2, 15:00-22:59 runs at fan speed level 3 and 23:00-24:00 runs at fan speed level 0. That is, when the current time reaches the set time, the ventilation system runs at the set fan speed level at the set

time until the next time period

- Long press the ▲ key for 5 seconds in timer mode to check the time of the filter, the original current time indication position displays the time (hours) that the filter operated, after the operated time of the filter exceeds the maximum operating time of the filter, the 📄 icon flashes
- Long press the ▼ key in the timer mode for 5 seconds to clear the filter time, long press the ⚙️ key (a sound of beep appears twice) to enter into the setting state of the maximum operating time of the filter, and adjust the parameters through pressing the ▲ and ▼ keys. (Setting range: 720-2999 hours, factory default: 2190 hours). (If the keys are not operated for more than 10 seconds during the setting process, the controller will automatically return to the normal operating state and save the setting parameters)
- Scan the QR code below with the smart phone to download the Tuya Smart APP to connect the ventilation system to the WiFi network, open the APP and follow the prompts to register an account and log in. Long press the M key for 5 seconds to let the ventilation system enter into the network configuration state (the 📶 icon flashes rapidly), then press the + icon on the upper right corner of the APP to add the ventilation system (select [Small Home Appliances] and then select [Ventilation System (BLE+WiFi)]), and follow the instructions on the APP to complete the connection to the WiFi network. After the network configuration completed successfully (the 📶 icon will be always ON), the ventilation system can be remotely controlled through the APP

- **Dimension:** 86x86x40mm
- **Mounting Hole Distance:** 60mm (standard)
- **Terminal:** 2.5 mm<sup>2</sup> wire max.
- **Rated Voltage:** AC230V
- **Rated Frequency:** 50/60Hz
- **Standby Power Consumption:** ≤2.0W
- **Drive Board Power Capacity:** ≤1500W
- **Output Interface:** EC/AC
- **Temperature Display Range:** -9°C to 99°C
- **Operating Temperature:** -10°C to +50°C
- **Operating Humidity:** 5%RH to 90%RH (non-condensing)
- **Storage Temperature:** -10°C to +60°C
- **Storage Humidity:** ≤60%RH



- If you have any specific problems during the use or maintenance of this product, contact the supplier or the maintenance department. Measures shall be taken after approval, otherwise the company will not be responsible for the consequences caused by the user's unauthorized changes
- The company will not bear any responsibility for the adverse consequences caused by the user's modification of the ventilation unit or the electronic control system without the permission of the company
- Due to the failure to install or use the ventilation unit as required, the company will charge corresponding fees for the after-sales service
  
- The contents of this user manual and the specifications of this product are subject to change without prior notice
- Download the latest user manual from [www.swift-air.com](http://www.swift-air.com)
- Contact us if you have questions regarding the configurations of this product
  
- The schematic diagram in this user manual is subject to the actual object

WARNING: DO NOT DISPOSE THE VENTILATION UNIT OR THE CONTROL PANEL OR THE ACCESSORIES IN DOMESTIC WASTE. PART OF THE PRODUCT MATERIALS CAN BE RECYCLED AND PART OF THE PRODUCT MATERIALS SHOULD NOT BE DISPOSED IN DOMESTIC WASTE. AT THE END OF THE SERVICE LIFE OF THE PRODUCT, PLEASE DISPOSE ACCORDING TO THE RELEVANT NATIONAL REGULATIONS

[www.Swift-Air.co.uk](http://www.Swift-Air.co.uk)

***SwiftAir***