

// 04

FIXED ADAPTOR

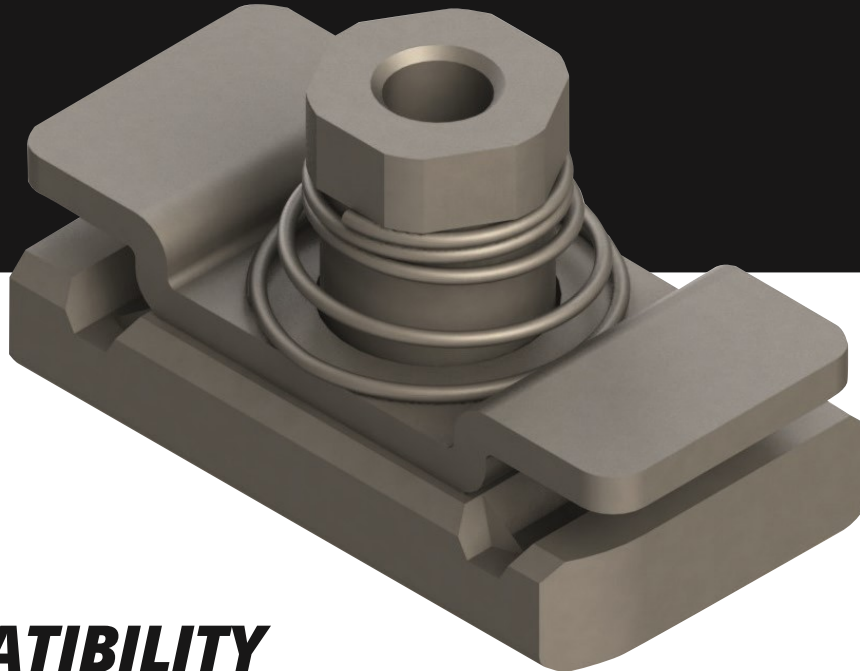

// COMPATIBILITY

WITH CHANNEL RAILS

HILTI <i>Channel system MQ for medium load)</i>	HALFEN <i>Medium duty channel system)</i>	UNISTRUT®
MQ-21, MQ-21U, MQ-21D	HM 41/22, HL 41/22, HM 41/22 D	P1000, P1000T, P1001, P1001T
MQ-31,	HZM 41/22, HZL 41/22, HZM 41/22 D	P2000, P2000T
MQ-41, MQ-41U, MQ-41D	HM 41/41, HL 41/41, HM 41/41 D	P3300, P3300T10, P3301, P3301T10
MQ-52, MQ-52-72D	HZM 41/41, HZL 41/41, HZM 41/41 D	P4000, P4000T10
MQ-72, MQ-72U	HM 41/62, HL 41/62, HM 41/62 D	P5000T, P5001T, P5500T, P5501T
	HM 41/83, HL 41/83	

Please contact us to check compatibility with additional types of channel rails.



// FIXED ADAPTOR FOR SERIES A

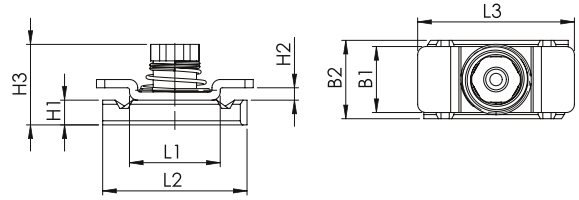
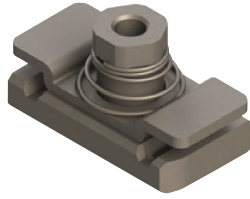

SIZE	BA Fixed adaptor																		
	L1	L2	L3	B1	B2	H1	H2	H3	d6										
1	BA-A/B1	22	35	38	16	19	6	3	19,5	M6									
2																			
3																			
4																			
5											0.87	1.38	1.50	0.63	0.75	0.24	0.12	0.77	¼-20 UNC
6																			
7																			
8																			

// FIXED ADAPTOR FOR SERIES B

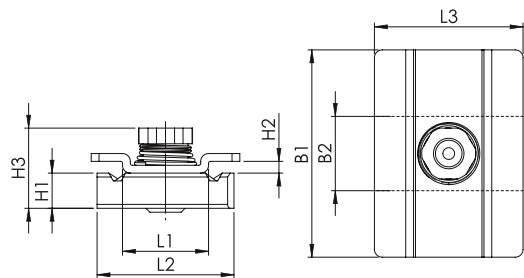

SIZE	BA Fixed adaptor									
	L1	L2	L3	B1	B2	H1	H2	H3	d6	
1	BA-A/B1	22	35	38	16	19	6	3	19,5	M6
					0.63		0.24		0.77	¼-20 UNC
2	BA-B2-3	0.87	1.38	1.50	53	0.75	9	0.12	23,5	M8
3					2.09					
4	BA-B4-5	0.87	1.38	1.50	80	0.75	0.35	0.12	0.93	5/16"-18 UNC
5					3.15					

dimensions $\frac{\text{mm}}{\text{Inch}}$



Available: galvanized and stainless steel
Also available in UNC

// FIXED ADAPTOR FOR SERIES C

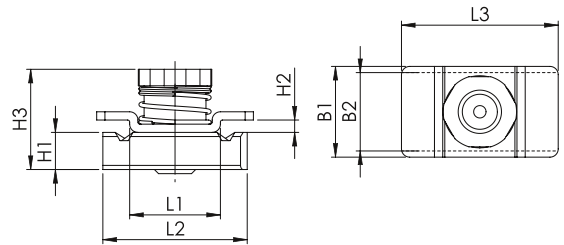
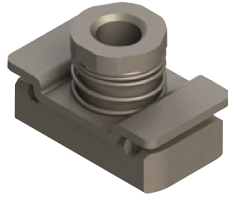

SIZE	BA Fixed adaptor								
	L1	L2	L3	B1	H1	H2	H3	d6	
1	22	35	38	22	9	3	24,3	M10	
2			1.50	0.87				0.96	3/8-16 UNC
3			0.87	1.38				45	25
4	0.87	1.38	1.77	0.98	0.35	0.12	1.02	7/16-14 UNC	

dimensions $\frac{\text{mm}}{\text{Inch}}$

// RECOMMENDED SCREW LENGTHS

WHEN USING FIXED ADAPTOR BA FOR SERIES C

SIZE	Hexagon head screw (with cover plate) x 4	Hexagon socket head screw (without cover plate)	Stacking bolt
1	M10 x 40	M10 x 20 *	M10 x 20 *
	3/8-16 UNC x 1 1/2	3/8-16 UNC x 3/4 *	3/8-16 UNC x 3/4 *
2	M10 x 55 *	M10 x 35 *	M10 x 35 *
	3/8-16 UNC x 1 1/3 *	3/8-16 UNC x 1 3/8 v*	3/8-16 UNC x 1 3/8 *
3	M10 x 65 *	M10 x 50 *	M10 x 50 *
	3/8-16 UNC x 1 1/4 *	3/8-16 UNC x 2 *	3/8-16 UNC x 2 *
4	M12 x 100	M12 x 75 *	M12 x 75 *
	7/16-14 UNC x 4	7/16-14 UNC x 3 *	7/16-14 UNC x 3 *

* for screws with special length (different from the catalogue) price on request

// BASIC DIMENSIONAL REQUIREMENTS

FOR CHANNEL RAILS TO BE USED WITH FIXED ADAPTOR BA

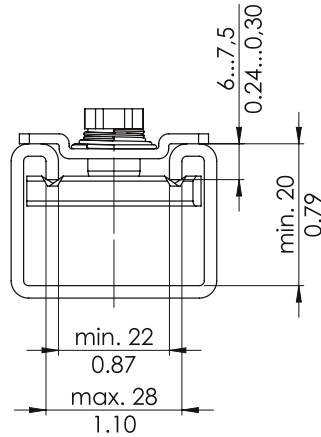

// EXAMPLE OF ORDER

BA-A/B1/Zn
 BA-B2-3/Mat.A4
 BA-C1-3/Zn/UNC

BA	-	A/B1	/	Zn
----	---	------	---	----

BA=Fixed adaptor

Serie
 A/B1
 B2-3
 B4-5
 C1-3
 C4

Features
 Zn= zinc plated
 Mat.A4= stainless steel A4
 UNC= UNC thread