

**TUBE CLAMPS SERIES C (HEAVY SERIES) | DIN 3015, PART 2 | COMPONENTS**

Complete range please refer to pages 43 to 48.

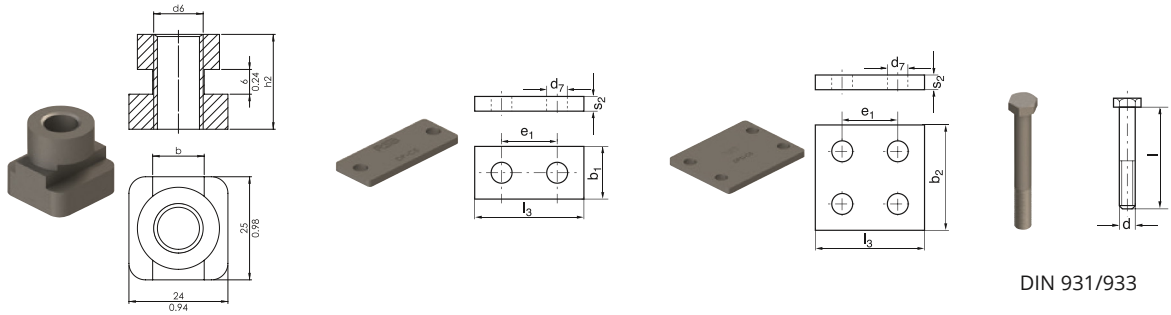

SIZE	TM-C Rail nut			DP-C Cover plate					DPD-C Cover plate, double					SS-C Hexagon head screw				
	h <sub>2</sub>	b	d <sub>6</sub>	l <sub>3</sub>	e <sub>1</sub>	b <sub>1</sub>	s <sub>2</sub>	d <sub>7</sub>	l <sub>3</sub>	e <sub>1</sub>	b <sub>2</sub>	s <sub>2</sub>	d <sub>7</sub>	d	x	l		
1	TM-C 1	20 0.79	12 0.47	M 10 3/16-16 UNC	DP-C 1	55 2.17	33 1.30	30 1.18	8 0.31	11 0.43	DPD-C 1	55 2.17	33 1.30	60 2.36	8 0.31	11 0.43	SS-C 1	M 10 x 40 3/8-16 UNC x 1 1/2
2					DP-C 2	70 2.76	45 1.77	30 1.18	8 0.31	11 0.43	DPD-C 2	70 2.76	45 1.77	60 2.36	8 0.31	11 0.43	SS-C 2	M 10 x 60 3/8-16 UNC x 1 3/8
3					DP-C 3	85 3.35	60 2.36	30 1.18	8 0.31	11 0.43	DPD-C 3	85 3.35	60 2.36	60 2.36	8 0.31	11 0.43	SS-C 3	M 10 x 70 3/8-16 UNC x 2 3/4
4	TM-C 4	23 0.91	12,5 0.49	M 12 7/16-14 UNC	DP-C 4	115 4.53	90 3.54	45 1.77	10 0.39	14 0.55	DPD-C 4	115 4.53	90 3.54	90 3.54	10 0.39	14 0.55	SS-C 4	M 12 x 100 7/16-14 UNC x 4
5					DP-C 5	152 5.98	122 4.80	60 2.36	10 0.39	18 0.71	DPD-C 5	152 5.98	122 4.80	120 4.72	10 0.39	18 0.71	SS-C 5	M 16 x 130 5/8-11 UNC x 5 1/4
6					DP-C 6	205 8.07	168 6.61	80 3.15	15 0.59	22 0.87	DPD-C 6	205 8.07	168 6.61	160 6.30	15 0.59	24 0.87	SS-C 6	M 20 x 190 3/4-10 UNC x 7 1/2
7					DP-C 7	251 9.88	205 8.07	90 3.54	15 0.59	28 1.10	DPD-C 7	250 9.88	205 8.07	180 7.09	15 0.59	28 1.10	SS-C 7	M 24 x 220 7/8-9 UNC x 8 3/4
8					DP-C 8	320 12.60	265 10.43	120 4.72	25 0.98	35 1.38	DPD-C 8	322 12.60	265 10.43	240 9.45	25 0.98	35 1.38	SS-C 8	M 30 x 300 1 1/8-7 UNC x 12
9					DP-C 9	470 18.50	395 15.55	160 6.30	30 1.18	35 1.38	DPD-C 9	470 18.50	395 15.55	330 12.99	30 1.18	35 1.38	SS-C 9	M 30 x 450 1 1/8-7 UNC x 17 1/2
10					DP-C 10	630 24.80	534 21.02	180 7.09	30 1.18	35 1.38	DPD-C 10	630 24.80	534 21.02	360 14.17	30 1.18	35 1.38	SS-C 10	M 30 x 560 1 1/8-7 UNC x 22

dimensions  $\frac{\text{mm}}{\text{Inch}}$

All metal parts available in stainless steel.

