

MX20AENC TS7 Built-in Blast Chiller / Freezer

Standard Features

- Designed to be built-in (on 5 sides)
- 7" ergonomic touch screen with large keys for ease of use
- User friendly operation with easy to use functions:
 - Hard or soft chill / freeze mode
 - Easy switch to probe or timer mode
 - Self Adaptive intelligent chilling mode
- Auxiliary functions: ice cream hardening, ventilated drying, multiple timers, customisable multiple phases, raw fish sanitation
- 40 program cycles with favourites key – shortcuts to last 9 programs used
- Pre-chilling cycle key to maximise efficiency
- Automatic hold mode after each cycle
- Manual defrosting with automatic control of time
- 3 point core temperature probe
- Timer mode or continuous run
- Integrated door latch to aerate cabinet when not in use
- Automatic fan stop when opening the door
- External and internal finish made of 304 stainless steel
- Heated door frame to reduce condensation
- Injected polyurethane foam insulation - 60mm thick



Please refer to Moffat price list for options and accessories

Technical data

Tray capacity	4 x 1/1GN trays
Tray clearance	74mm
External dimensions	W 900mm x D 695mm x H 820mm
Load capacity	20kg chill / 10kg freeze*
Electrical connections	1P+N+E, 230-240V, 50/60Hz, 10A, 1.6kW
Nett weight	115kg
Air-cooled condensing unit - Refrigerant type R452A	
Ambient temperature requirement +15°C — +32°C	

* Note – Load capacities may vary depending on the thermal conductivity of the food being chilled, the thickness of product and container used

Dimensions

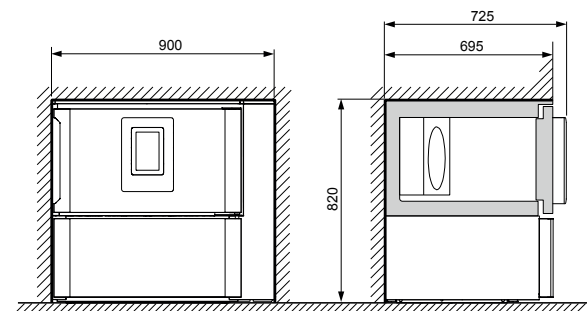

(A) Electrical supply
(CU) Useful

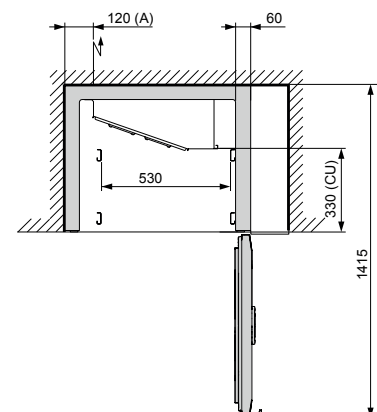

Australia
moffat.com.au

Moffat Pty Limited
740 Springvale Road
Mulgrave
Victoria 3170
Australia
Telephone +613-9518 3888
Facsimile +613-9518 3833
vsales@moffat.com.au

New Zealand
moffat.co.nz

Moffat Limited
45 Illinois Drive
Izone Business Hub
Rolleston 7675
New Zealand
Telephone +64 3-983 6600
Facsimile +64 3-983 6660
sales@moffat.co.nz

Disclaimer: All unit capacities are based on subjective testing. Moffat accepts no liability for production values. In line with policy to continually develop and improve its products, Moffat Limited reserves the right to change specifications and design without notice.

© Copyright Moffat Ltd
AN-FRI-S-2101



an Ali Group Company



The Spirit of Excellence