

**Step1: Side cabinet installation**  
 Please connect the drawer, standing boards with back board firstly; and secondly connect with bottom board

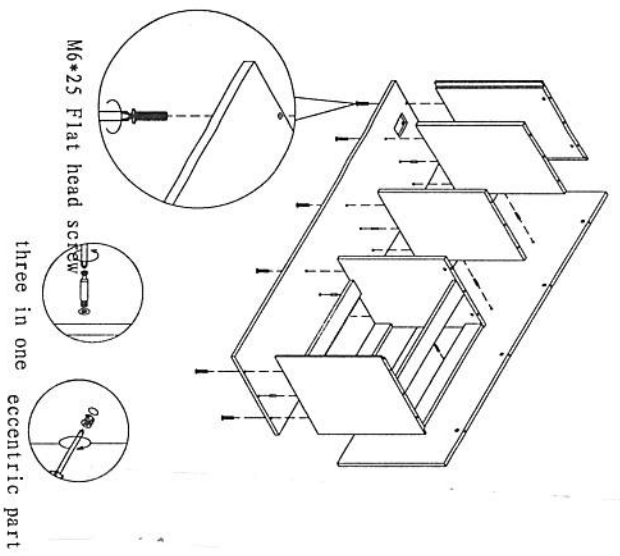

M6\*25 Flat head screw  
 three in one eccentric part

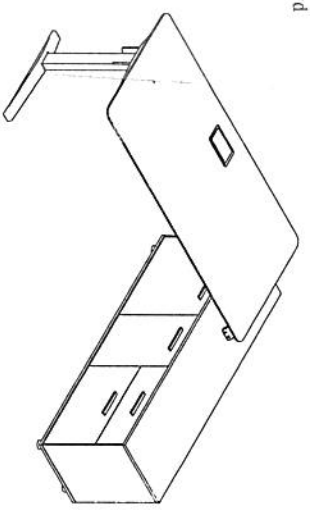

ITEM NO: **GOPS-APP20** LHS/RHS  
 NAME: Manager desk with lifting system  
 Dimension: 2000\*1820\*750-1100

**Step3: Cabinet feet installation**

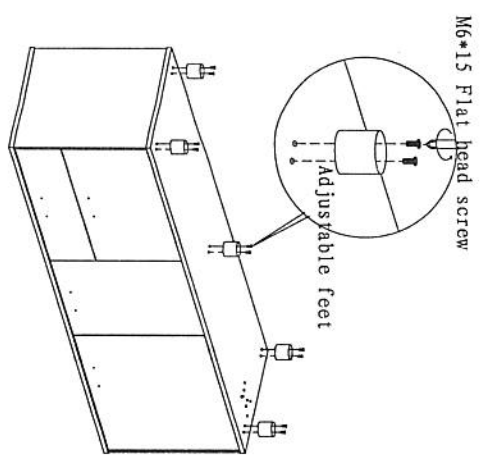

M6\*15 Flat head screw  
 adjustable feet

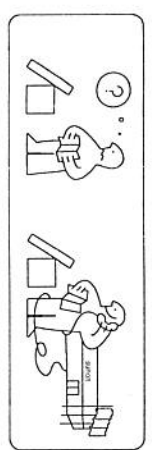
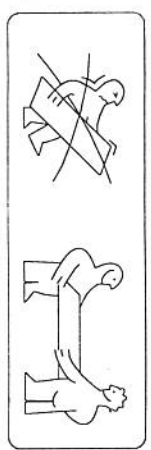
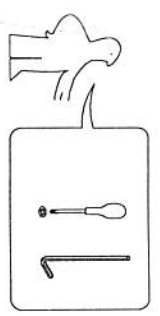

**Step 2: Side cabinet installation**  
 After finishing the installation of top board, please install the drawer and door boards

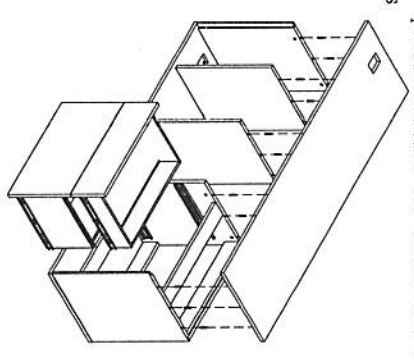

M6\*25 Flat head screw  
 three in one eccentric part

Step 4: Handle installation

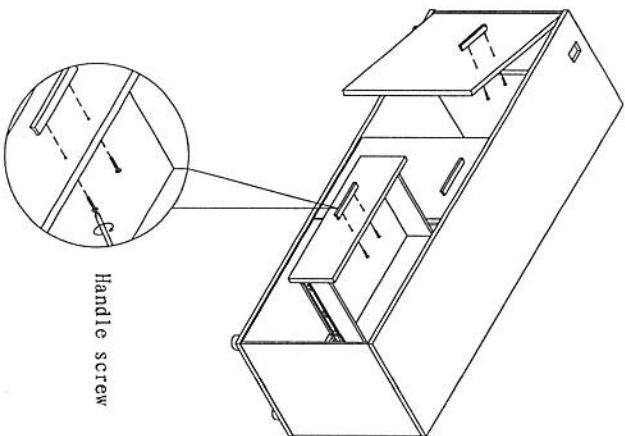

Handle screw

Step 5: Electric lifting steel leg installation  
After installing the plastic shell, please insert the leg into side cabinet

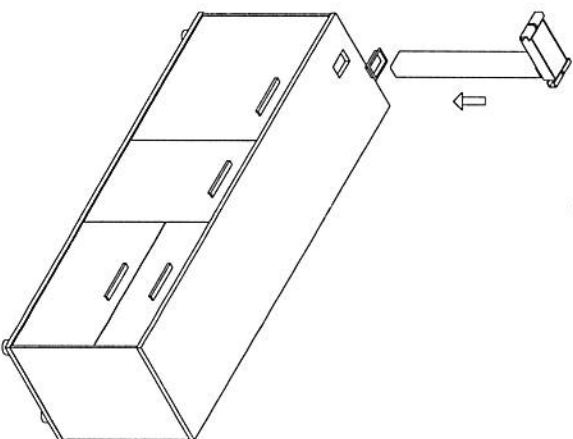

Step6: Connecting plate installation

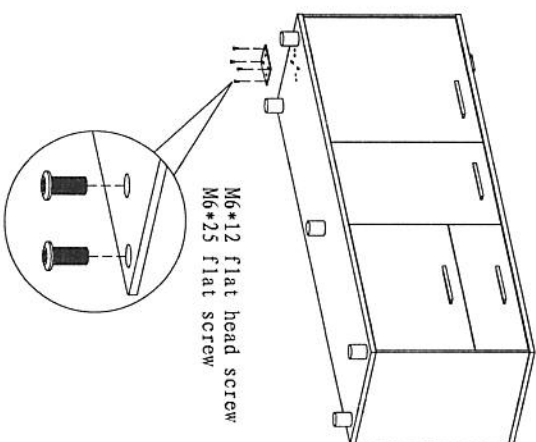

M6\*12 flat head screw  
M6\*25 flat screw

Step 7: Feet pad and electric lifting steel leg installation

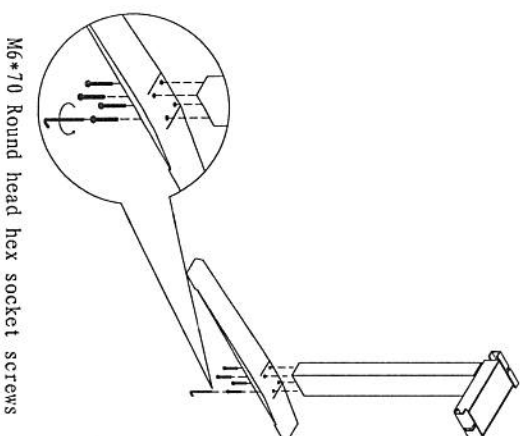

M6\*70 Round head hex socket screws

Step8: Steel beam cover the steel leg and use the two L-shape steel to fix them.

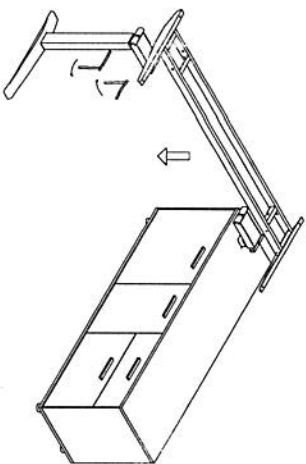

Step9: Wire channel and motor installation

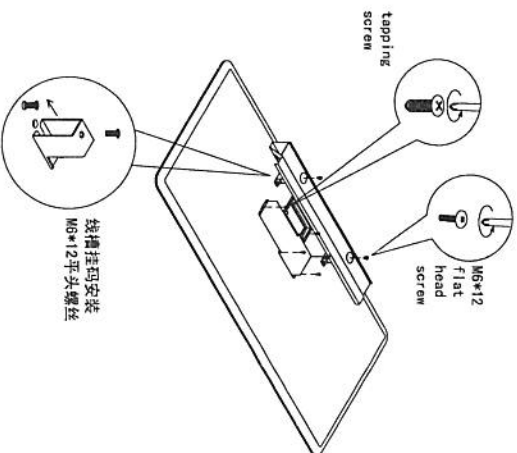

tapping screw

M6\*12 flat head screw

线槽挂码安装  
M6\*12平头螺丝

Step9: Modesty panel installation  
Install the conenctor on modestly panel firstly and then install the other conenctor underneath the desktop

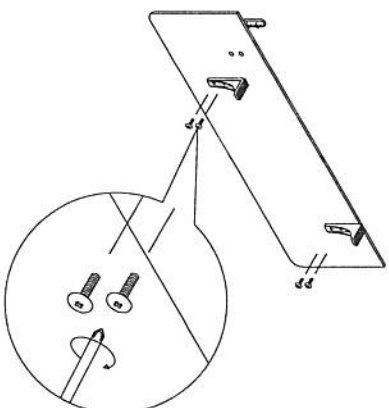

Step9: Desktop and steel frame installation

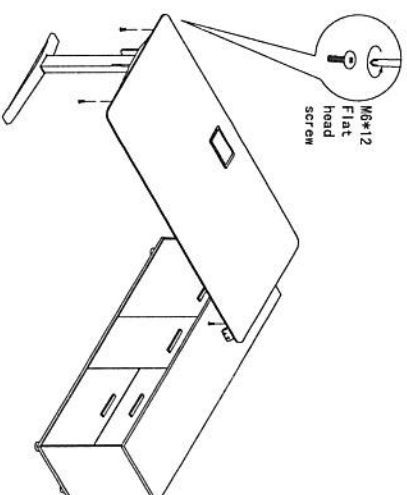

M6\*12 flat head screw