

# Modulus Flip Table

## Installation Guide

---



**TOOLS REQUIRED:** Powered screwdriver



# MODULUS FILP TABLE

## Installation Guide

\* To prevent possible scratches or damage, assemble the table upside down on a soft surface such as a blanket, carpet or packaging.



\* Attach Leg to the Top assembly by using Bolts, spring washer, flat washer. Tighten using the Allen Wrench provided.

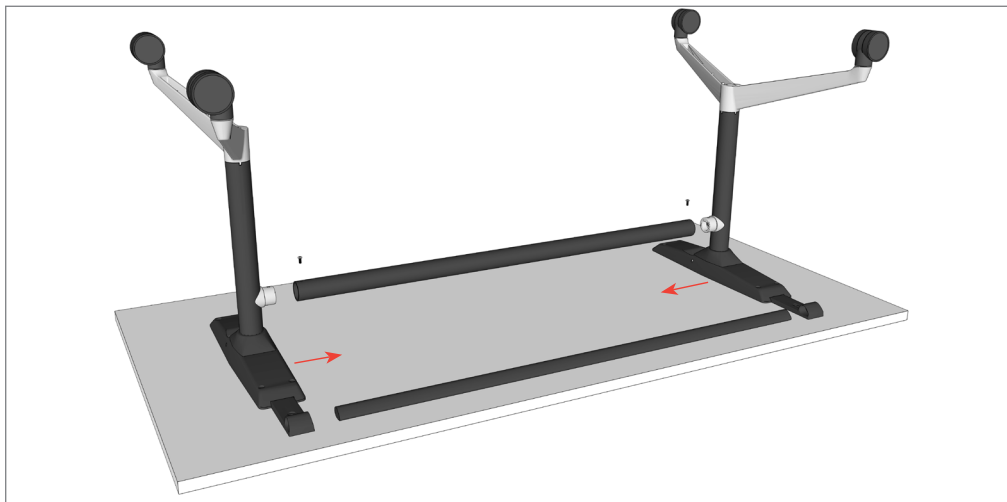
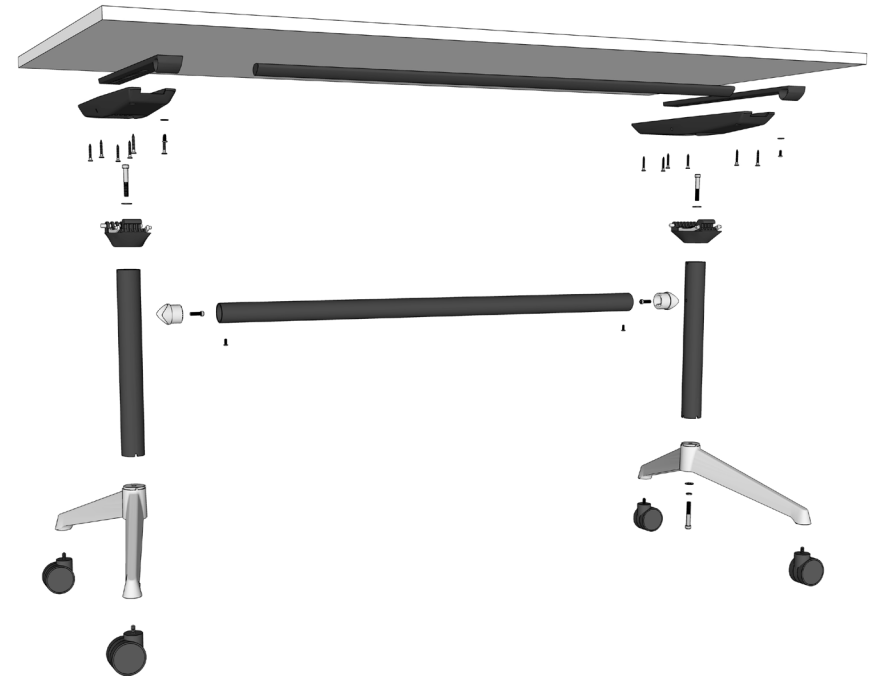

**STEP 1:** Place the pull bar (a) and cross tube (b) in the correct location pictured above, slide the 2 end legs in place

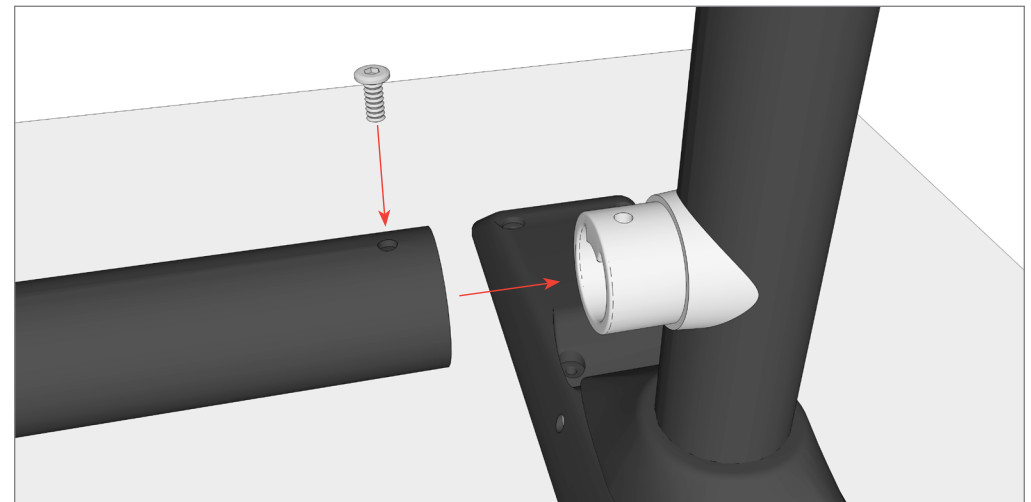

**STEP 2:** Fully tighten 2 small screws into the cross tube.

# MODULUS FILP TABLE

## Installation Guide

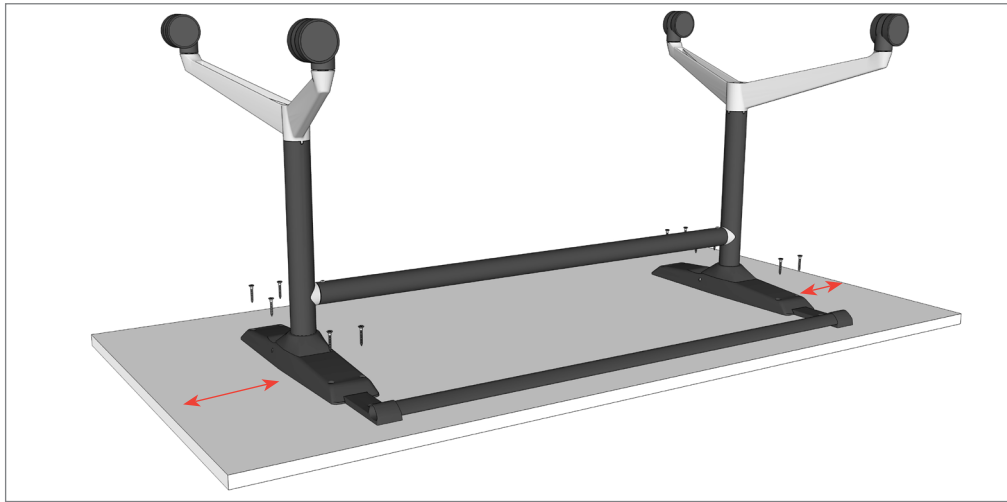

**STEP 3:** Ensure the frame is located in the centre of the worksurface.

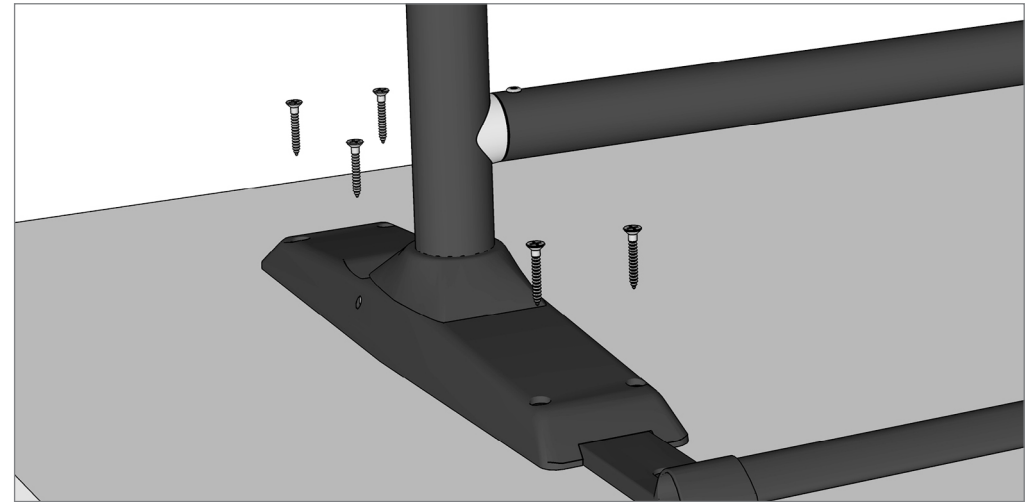

**STEP 4:** Fully tighten all 6 screws on each mechanism.

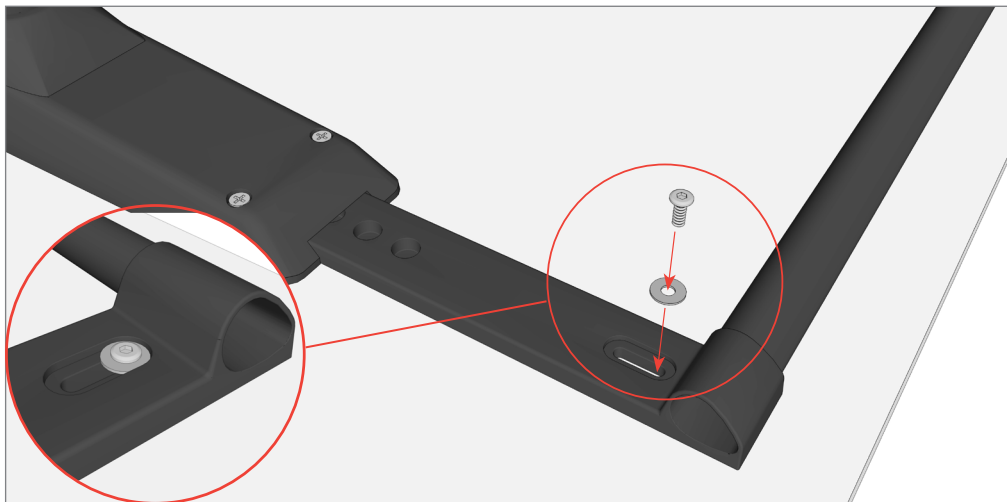

**STEP 5:** On all tables with width larger than 700mm, secure the pull bar with the supplied washer and screw in the location pictured above (slot end closest to the pull-bar). Leave screw 1 turn from tight so the pull-bar can be operated smoothly.



**COMPLETE:** Using 2 people rotate table into upright position.

# MODULUS FILP TABLE - CONNECTORS/LINKS

## Installation Guide

### Drilling Patterns for Optional Connectors/Links

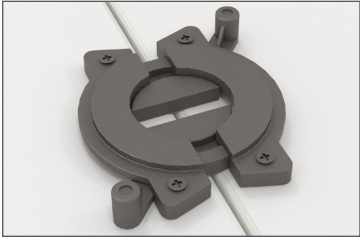

Locked

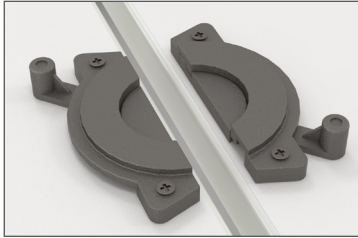

Unlocked

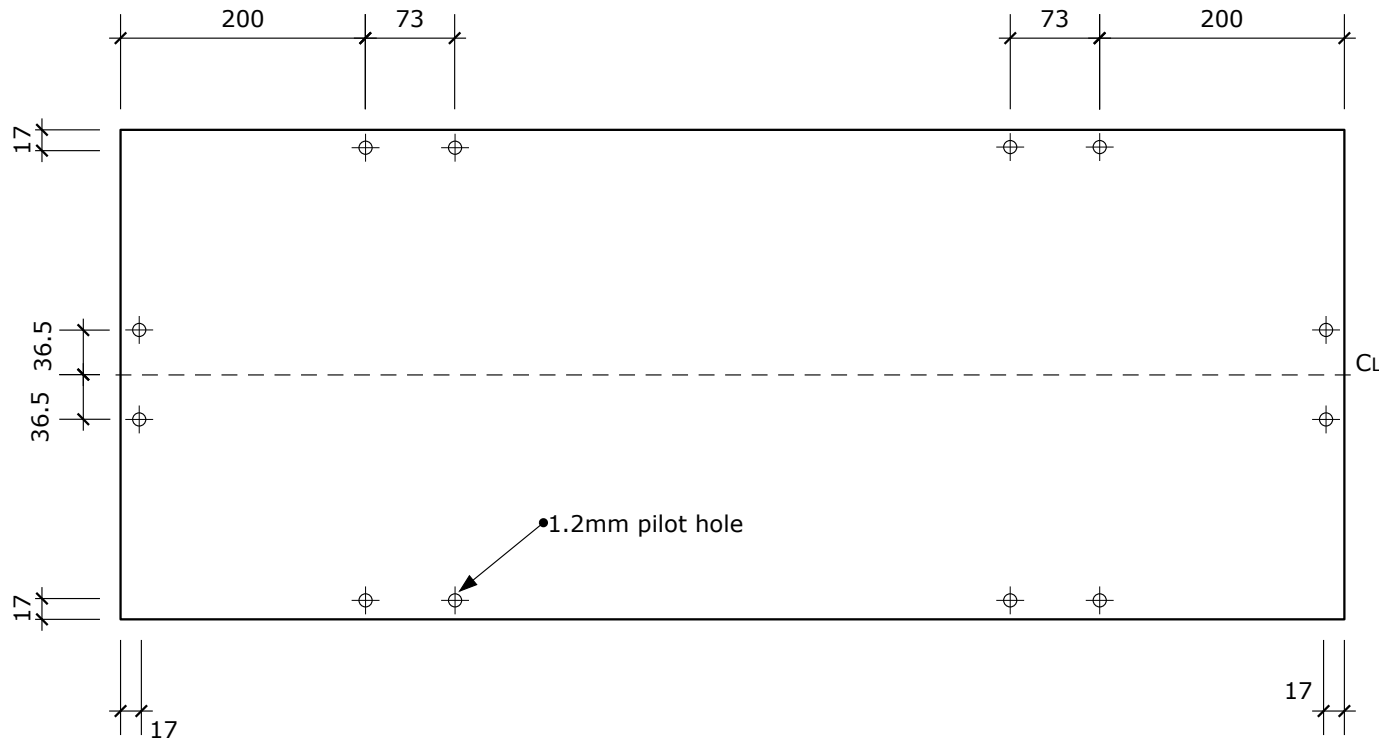

# MODULUS FLIP TABLE

## Installation Guide

### Drilling Patterns for Modulus/Uni Flip Tables Mechanism & Pull Bar

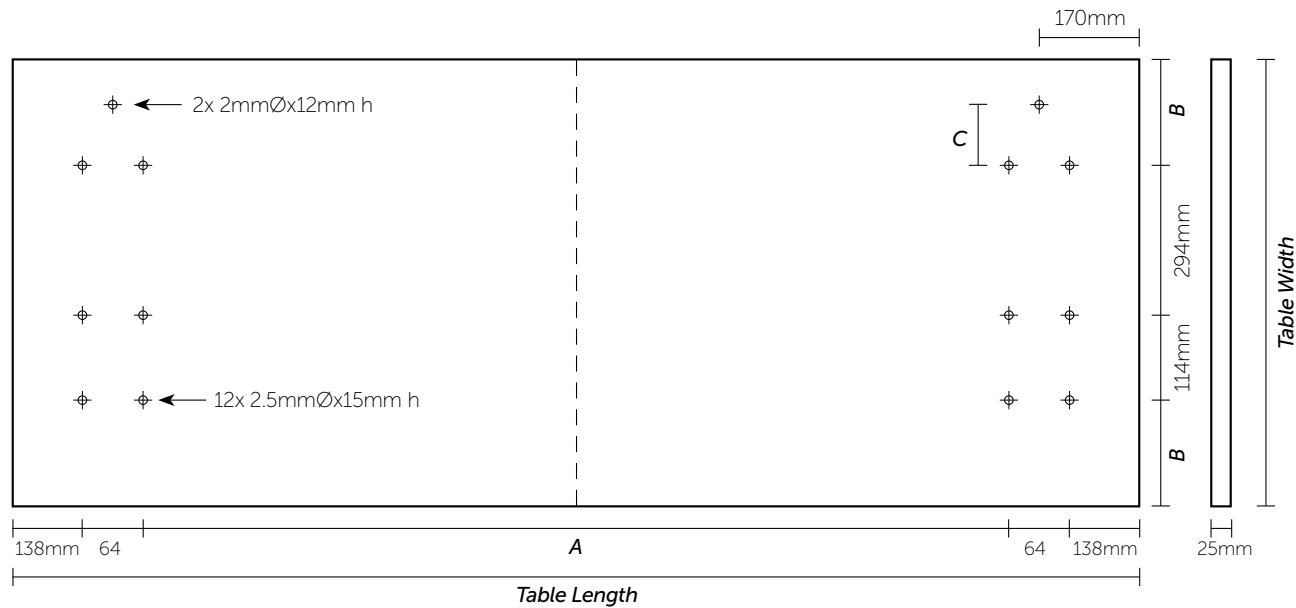

Width-600mm	A	B	C
1200mm	796	96	NA
1500mm	1096	96	NA
1800mm	1396	96	NA

Width-750mm	A	B	C
1200mm	796	171	100
1500mm	1096	171	100
1800mm	1396	171	100

Width-900mm	A	B	C
1200mm	796	246	175
1500mm	1096	246	175
1800mm	1396	246	175

