

# ALPINE DAYBED

## ASSEMBLY INSTRUCTIONS

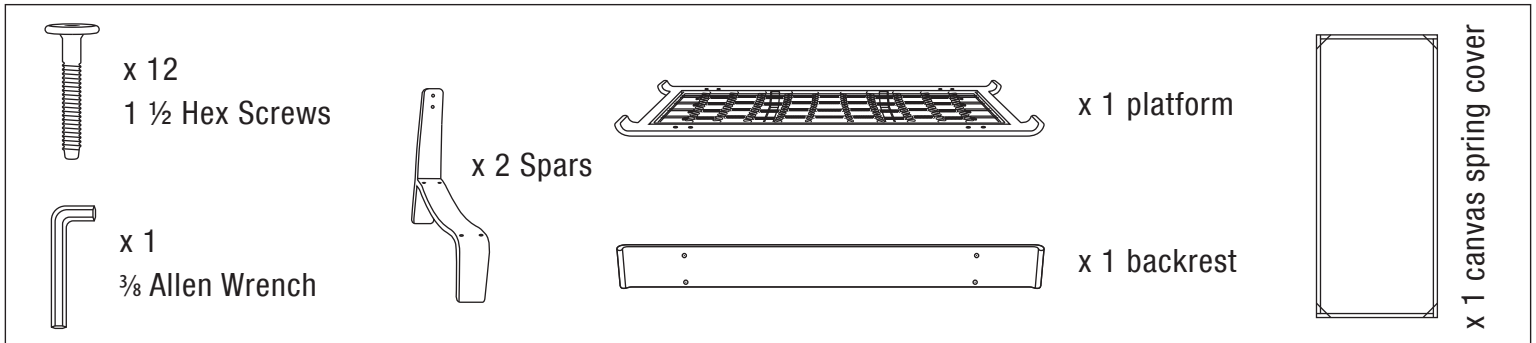

① Lay both of the spars on their backs with the feet facing away from you.

② Align the holes on the backrest with the holes on the spars. Insert screws into the holes and loosely tighten.

③ Once all the screws are in the holes tighten fully in a diagonal pattern.

④ Flip the spars and backrest upright onto the feet.

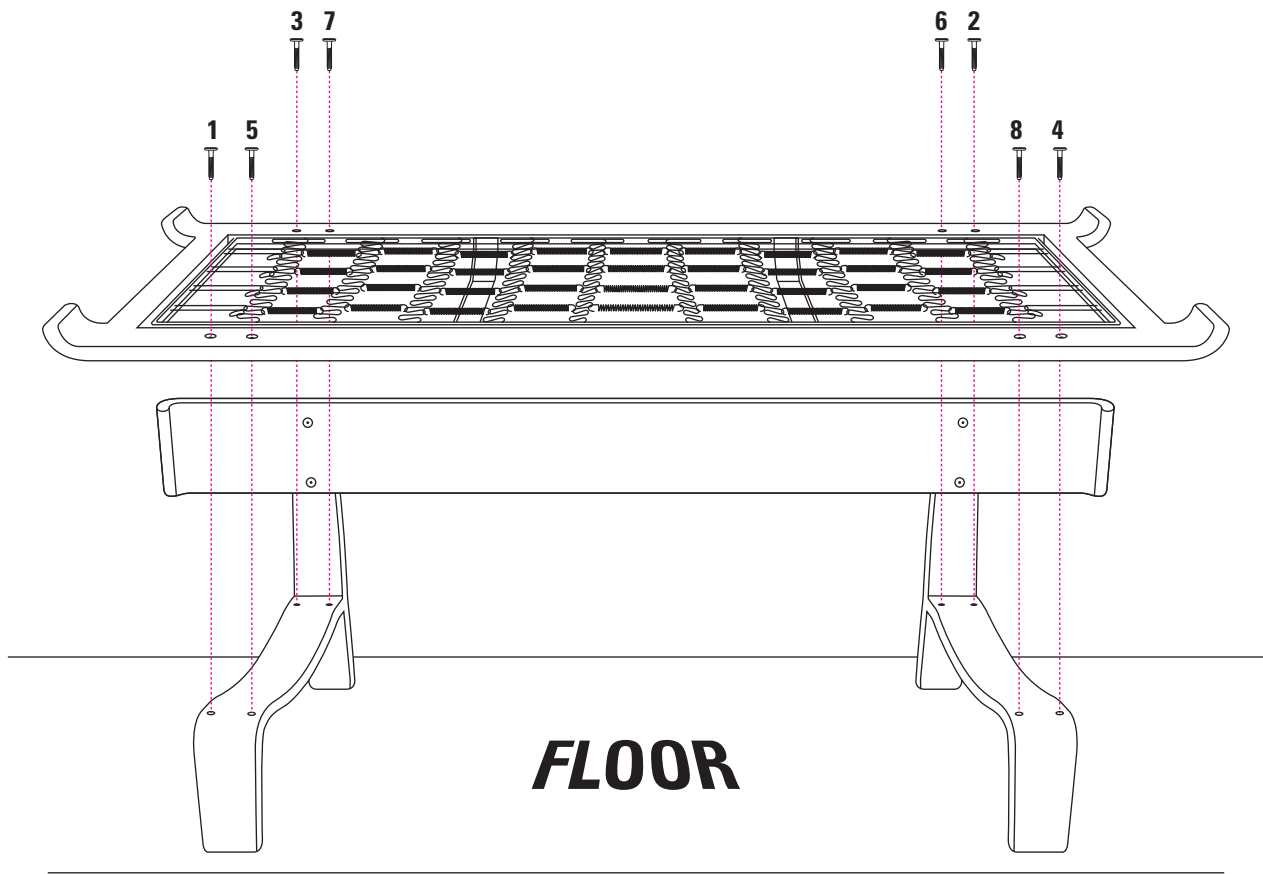

- ⑤ Align the holes on the platform with the holes on the spars.  
Insert the screws into the holes in the order shown above and loosely tighten.
- ⑥ Once all the screws are in the holes  
tighten fully in the order shown above.

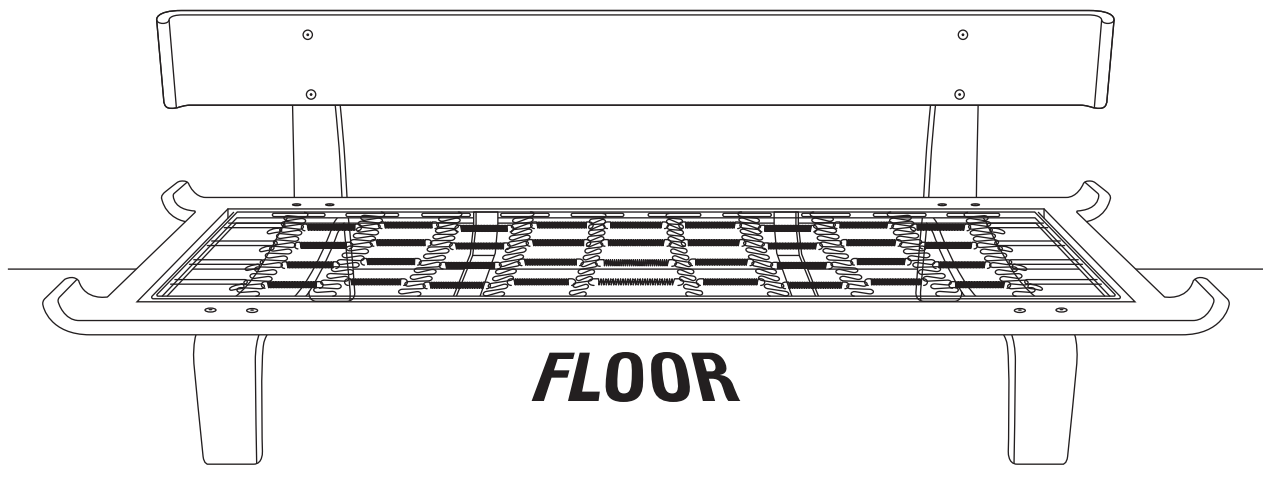

- ⑦ To attach the canvas spring cover, slide the elastic over the corners of the metal frame containing the springs.

**Done!**