

**OMGE** GUIDE PER **APPLICAZIONI SPECIALI** / RUNNERS FOR **SPECIAL APPLICATIONS**

**Peko 3402**

**120 kg** PORTATA  
CARRYING CAPACITY

**GUIDA IN ACCIAIO TRAFILATO AD ALTA CAPACITÀ DI CARICO**

HIGH LOAD CAPACITY COLD DRAWN CARBON STEEL SLIDE



**ESTRAZIONE 90%**  
90% EXTENSION



**FISSAGGIO LATERALE**  
SIDE MOUNTING

**ESEMPIO DI APPLICAZIONE / EXAMPLE OF APPLICATION**



Portata massima kg 120.

Guida realizzata in acciaio trafilato a freddo ad estensione 90% particolarmente indicata per applicazioni speciali ad incasso del profilo esterno.

La capacità di carico si riferisce alla portata della guida con fissaggio verticale, un eventuale fissaggio in orizzontale riduce notevolmente la portata.

La robustezza della guida garantisce un perfetto funzionamento con minima flessione in posizione di estrazione anche al carico massimo.

A richiesta è possibile produrre lunghezze specifiche in accordo alle esigenze del cliente.

Carrying capacity kg 120.

90% extension slide made of cold drawn steel particularly intended for special outer profile built-in applications.

The carrying capacity is referred to the slide installed in vertical position, the installation in horizontal position involves a significant reduction of the load capacity.

The strength of the slide ensures a perfect functioning with a minimum bending even at the maximum load when the slide is extended.

On demand we can manufacture different lengths according to the customer needs.

**Peko 3402** SPECIFICHE TECNICHE / TECHNICAL SPECIFICATIONS

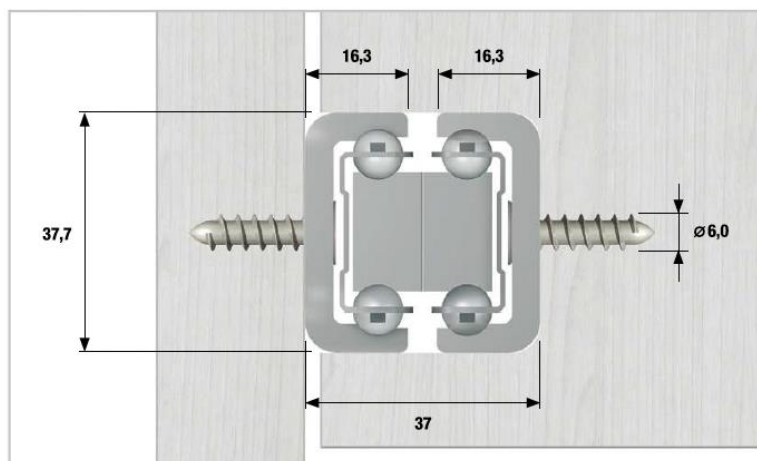

Profilo interno in acciaio trafilato a freddo con spessore 11 mm.  
 Profilo esterno in acciaio trafilato a freddo con spessore 4,50 mm.  
 Gabbia in acciaio con sfere in acciaio 5/16".  
 Finitura acciaio zincato.

Internal profile made of cold drawn steel with thickness 11 mm.  
 External profile made of cold drawn steel with thickness 4,50 mm.  
 Steel cage with steel balls 5/16".  
 Finishing zinc plated steel.



**SCHEMA FORATURA / HOLE PATTERN**

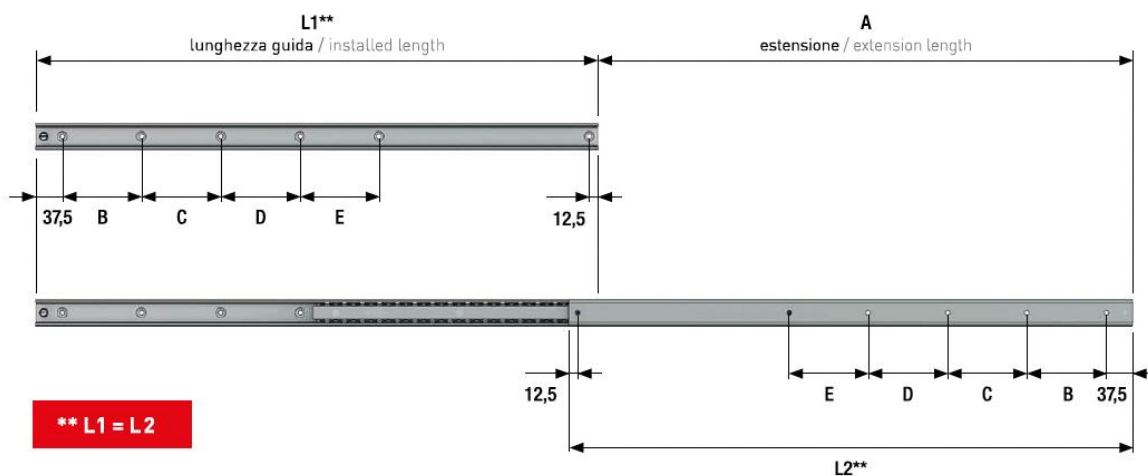

**\*\* L1 = L2**

Codice XXXX* Code XXXX*	L1/L2 mm	A mm	B mm	C mm	D mm	E mm	Imballo Packing
<b>0600</b>	600	533	150	150	—	—	<b>4</b>
<b>0800</b>	800	733	150	150	150	—	<b>4</b>
<b>1000</b>	1000	933	150	150	150	—	<b>4</b>
<b>1200</b>	1200	1133	150	150	150	150	<b>4</b>

\*Codice / Ordering Code: **03402/000/00/XXXX/00**