

T-ABLE XL

ISTRUZIONI DI MONTAGGIO ASSEMBLY INSTRUCTIONS

MODELLI:
MODELS:

- 411/78.1900.22X - T-Able XL per modulo da 600 mm spalle da 15 a 20 mm
T-Able XL for 600 mm module, sides thickness: 15-20 mm
- 411/78.1910.22X - T-Able XL per modulo da 900 mm spalle da 15 a 20 mm
T-Able XL for 900 mm module, sides thickness: 15-20 mm
- 411/78.1920.22X - T-Able XL per modulo da 1200 mm spalle da 15 a 20 mm
T-Able XL for 1200 mm module, sides thickness: 15-20 mm

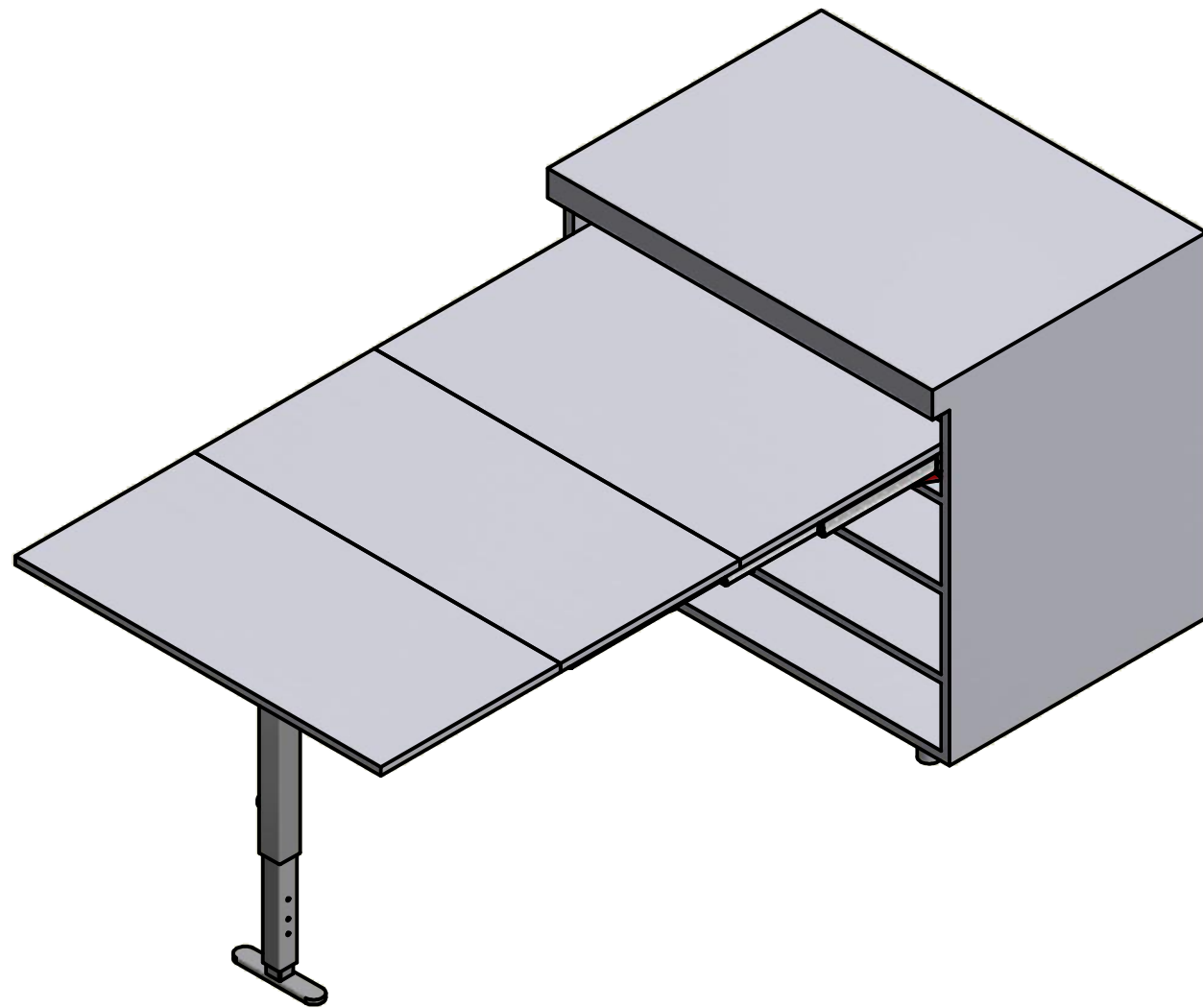

CONTENUTO DELLA CONFEZIONE INCLUDED IN THE PACKAGING

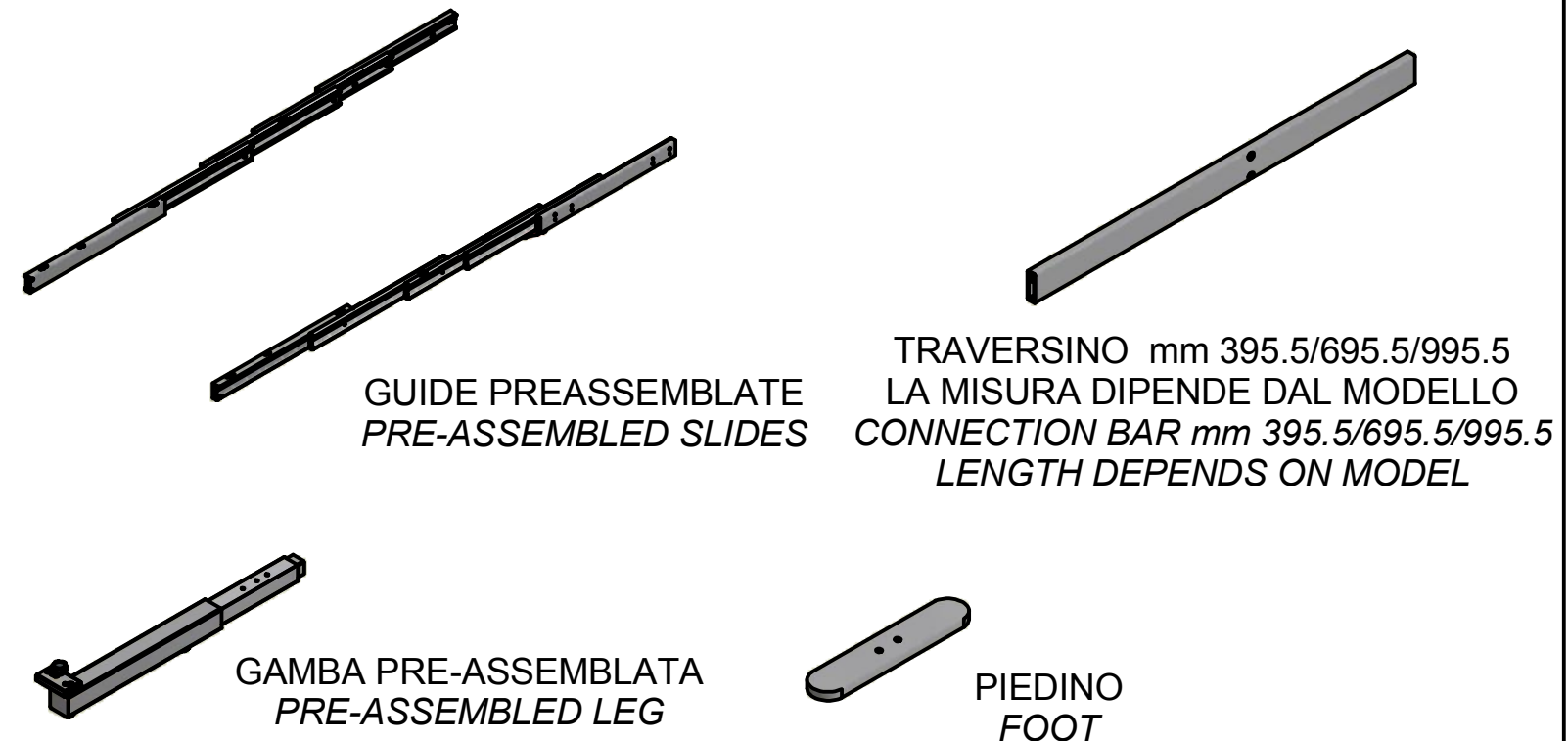

SACCHETTO ACCESSORI - ACCESSORIES

- A. Chiave esa. n.3 - n° 3 Allen key
- B. Chiave esa. n.4 - n° 4 Allen key
- C. Chiave esa. n.5 - n° 5 Allen key
- D. Distanziale per spalla - Side spacer (x 20)
- E. Bussola in ottone M6 12x8 mm - M6 12x8 mm brass bush (x 14)
- F. Vite TCBCE M5x10 ISO 7380 - M5x10 ISO 7380 screw (x 8)
- G. Vite TCCE M6x12 - M6x12 socked head cap screw (x 12)
- H. Vite TPS M6x16 - M6x16 screw (x 2)
- I. Vite trilobata M6x25 - M6x25 self threading screw (x 2)
- J. Vite TCCE M6x60 - M6x60 socked head cap screw (x 4)
- K. Perno blocco piano - Pin for blocking plane (x 1)

DIMENSIONI DI MASSIMA GENERAL DIMENSIONS

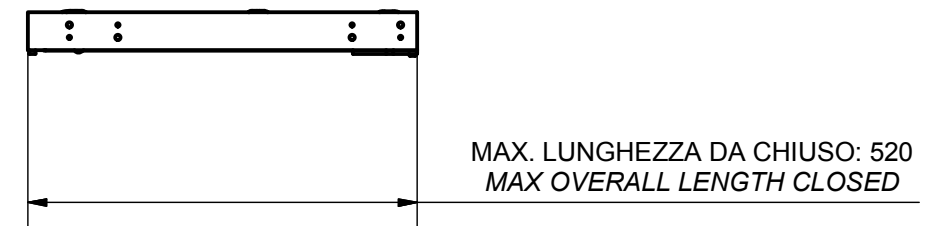
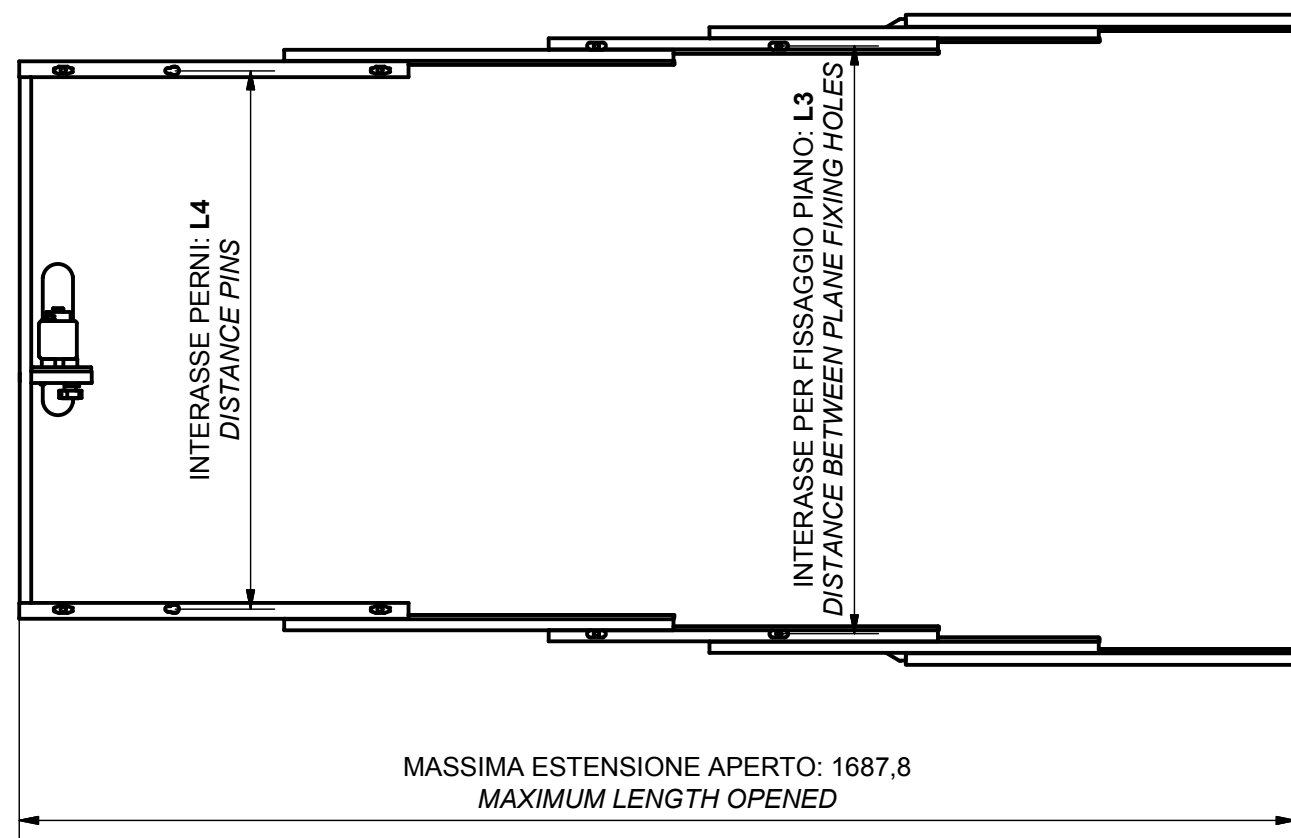
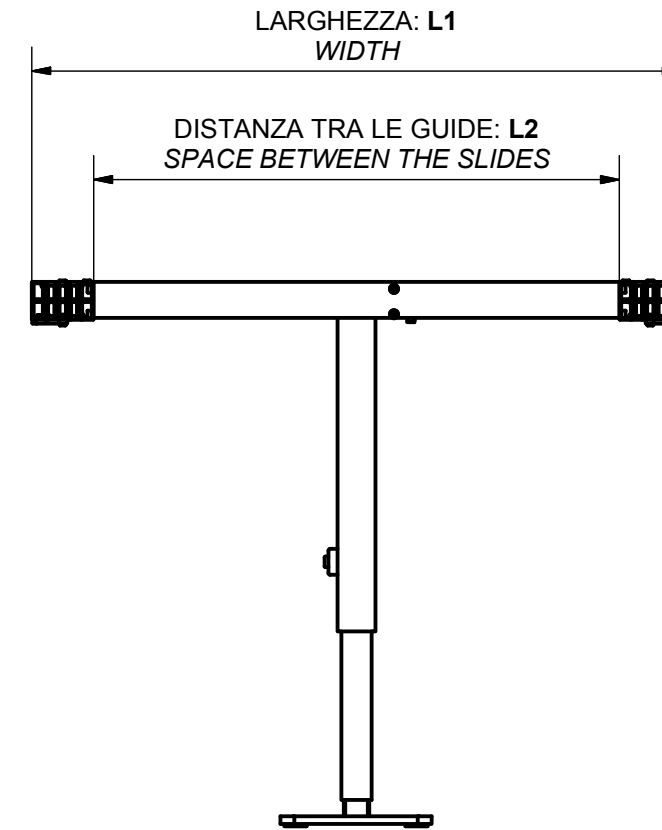
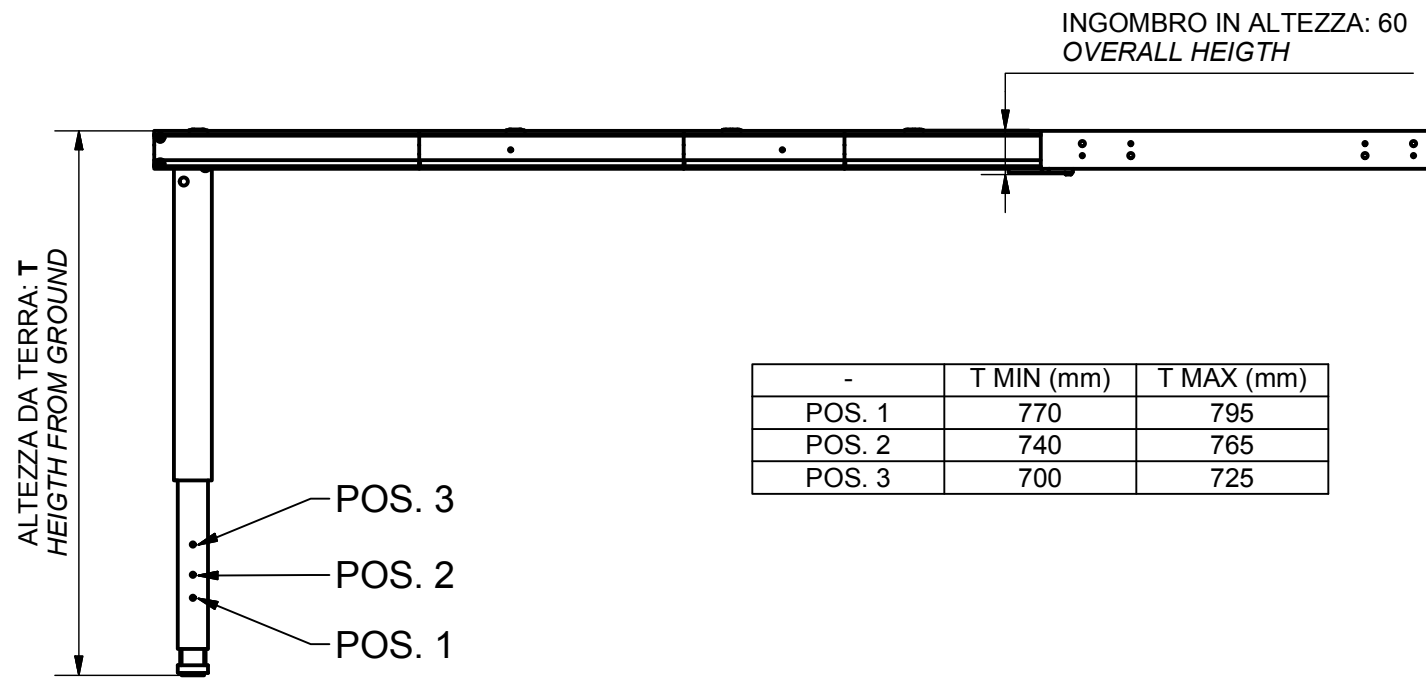

CODICE - CODE	MODULO - MODULE	L1 - MIN/MAX (mm)	L2 (mm)	L3 (mm)	L4 (mm)
411/78.1900.22X	600	560/570	395.5	478	412
411/78.1910.22X	900	860/870	695.5	778	712
411/78.1920.22X	1200	1160/1170	995.5	1078	1012

DIMENSIONI GENERALI MOBILE GENERAL CABINET DIMENSIONS

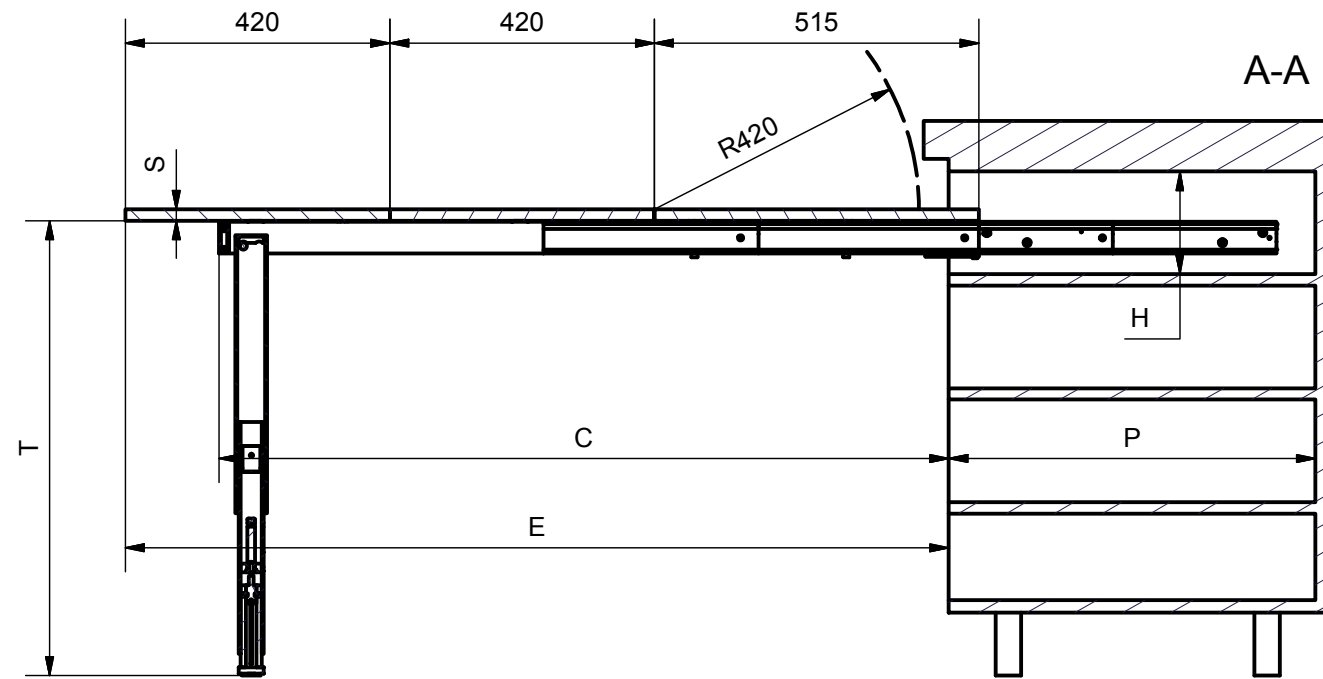

DIMENSIONE - DIMENSION	SIMBOLO - SYMBOL	-
LUCE VERTICALE - VERTICAL FREE SPACE	H	MIN: 130 mm
PROFONDITA' INTERNA - INTERNA FREE SPACE	P	MIN: 520 mm
LARGHEZZA INTERNA MODULO - CABINET INTERNAL WIDTH	L	MIN: 560 mm MAX: 1170 mm
SPESSORE SPALLA - SIDE THICKNESS	S1	15-20 mm
SPESSORE PIANI - PLANES THICKNESS	S	18-22 mm
LARGHEZZA PIANI - PLANES WIDTH	Z	L-5 mm
APERTURA MAX PIANI - MAX OPENING PLANES	E	1310 mm
APERTURA MAX MECCANISMO - MAX OPENING MECHANISM	C	1168 mm
ALTEZZA DA TERRA - HEIGTH FROM GROUND	T	MIN: 700 mm MAX: 795 mm

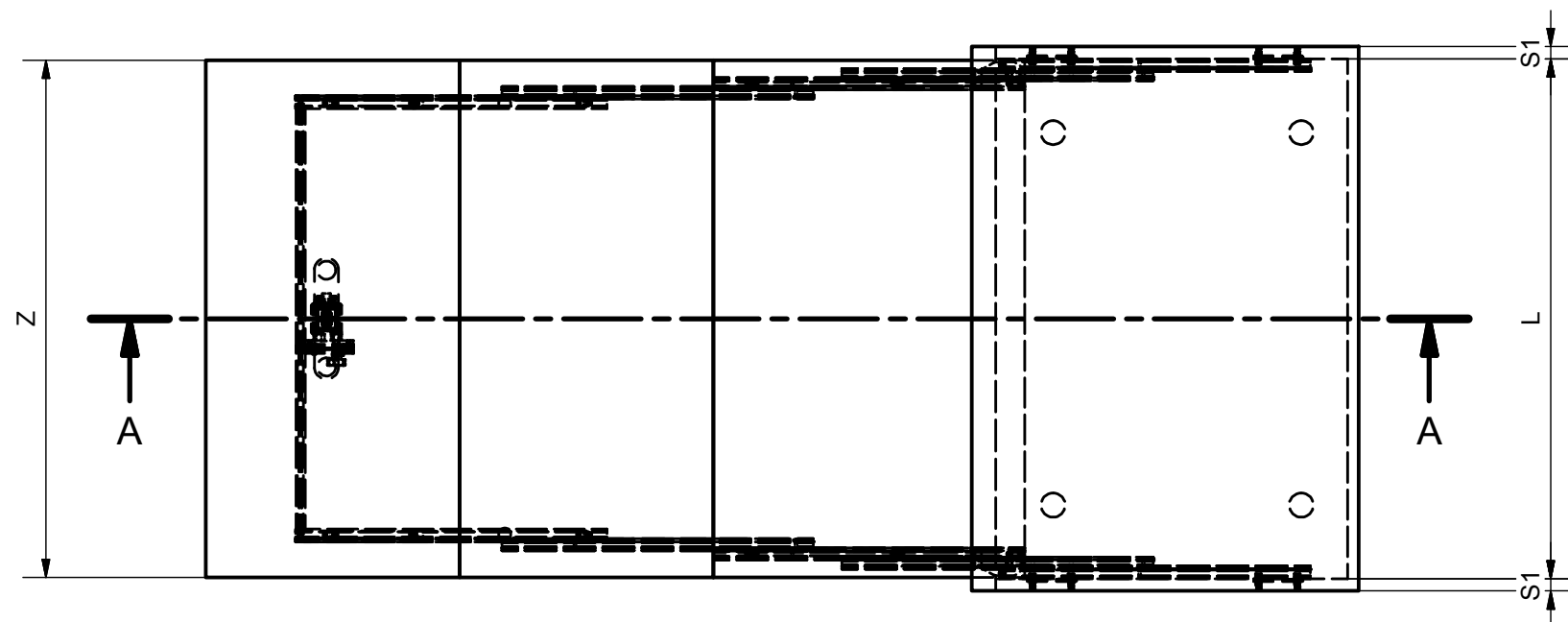

POSIZIONE FORI FISSAGGIO MECCANISMO

HOLES FOR MECHANISM POSITION

A: Posizione fori diam. 8x13 per bussole M6

Position of diam. 8x13 holes for M6 bushes

B: Posizione scarichi da Ø10x5 per testa viti fissaggio distanziali

Position of Ø10x5 holes for the heads of screws fixing the spacers

Per spalle di spessore < 20 mm usare i distanziali in ferro a corredo fissandoli sulle guide esterne.

For cabinet sides <20 mm use included steel spacers fixing them on the external slides

Spalla da 20 mm - nessun distanziale

Spalla da 19 mm - 1 distanziale

Spalla da 18 mm - 2 distanziale

Spalla da 17 mm - 3 distanziale

Spalla da 16 mm - 4 distanziale

Spalla da 15 mm - 5 distanziale

Side thickness 20 mm - no spacer

Side thickness 19 mm - 1 spacer

Side thickness 18 mm - 2 spacers

Side thickness 17 mm - 3 spacers

Side thickness 16 mm - 4 spacers

Side thickness 15 mm - 5 spacers

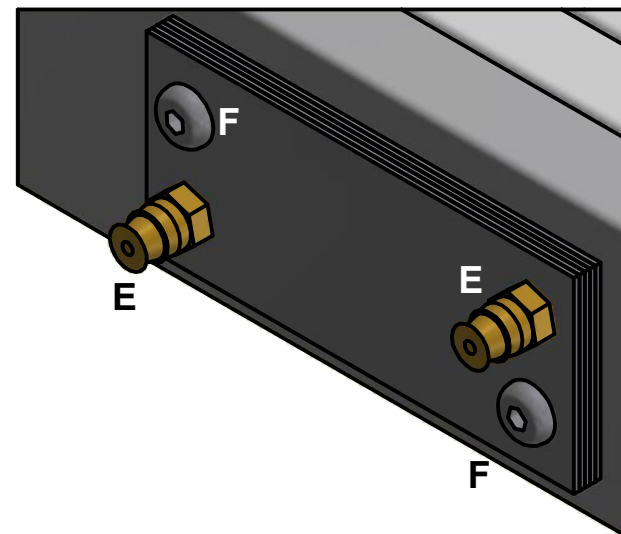

La quota indicata di 53 mm, lascia uno spazio tra lato inferiore guide e pianetto sottostante di circa 25 mm

The indicated 53 mm dimension is to allow a free space between the bottom of the slides and the plane of 25 mm



A. Chiave esa. n.3 - n.3 Allen key



D. Distanziale per spalla - Side spacer (x 20)



E. Bussola in ottone M6 12x8 mm - M6 12x8 mm brass bush (x 4)



F. Vite TCBCE M5x10 ISO 7380 - M5x10 ISO 7380 screw (x 8)

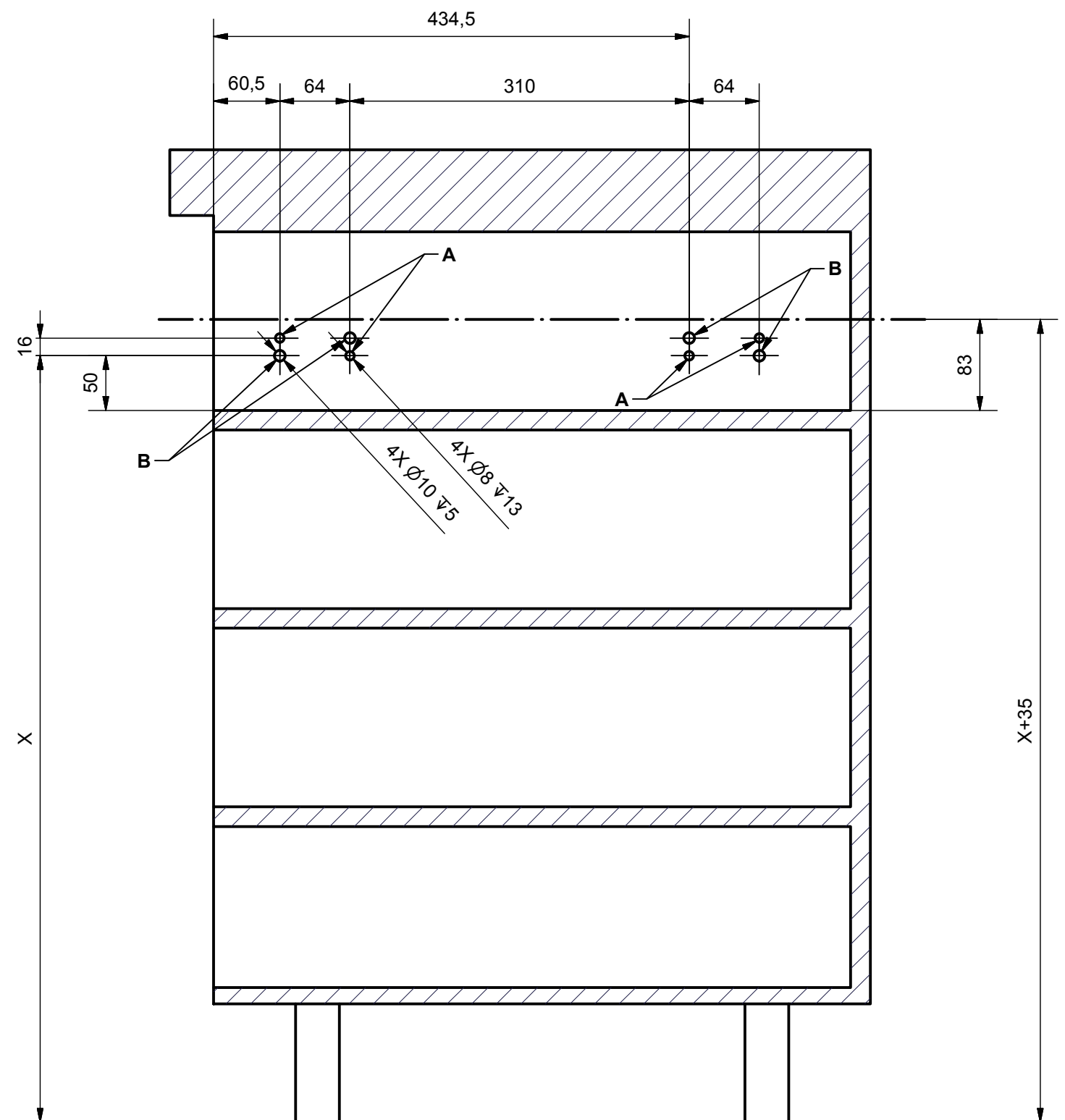

DIMENSIONI E FISSAGGIO PIANI

PLANES DIMENSIONS AND MOUNTING

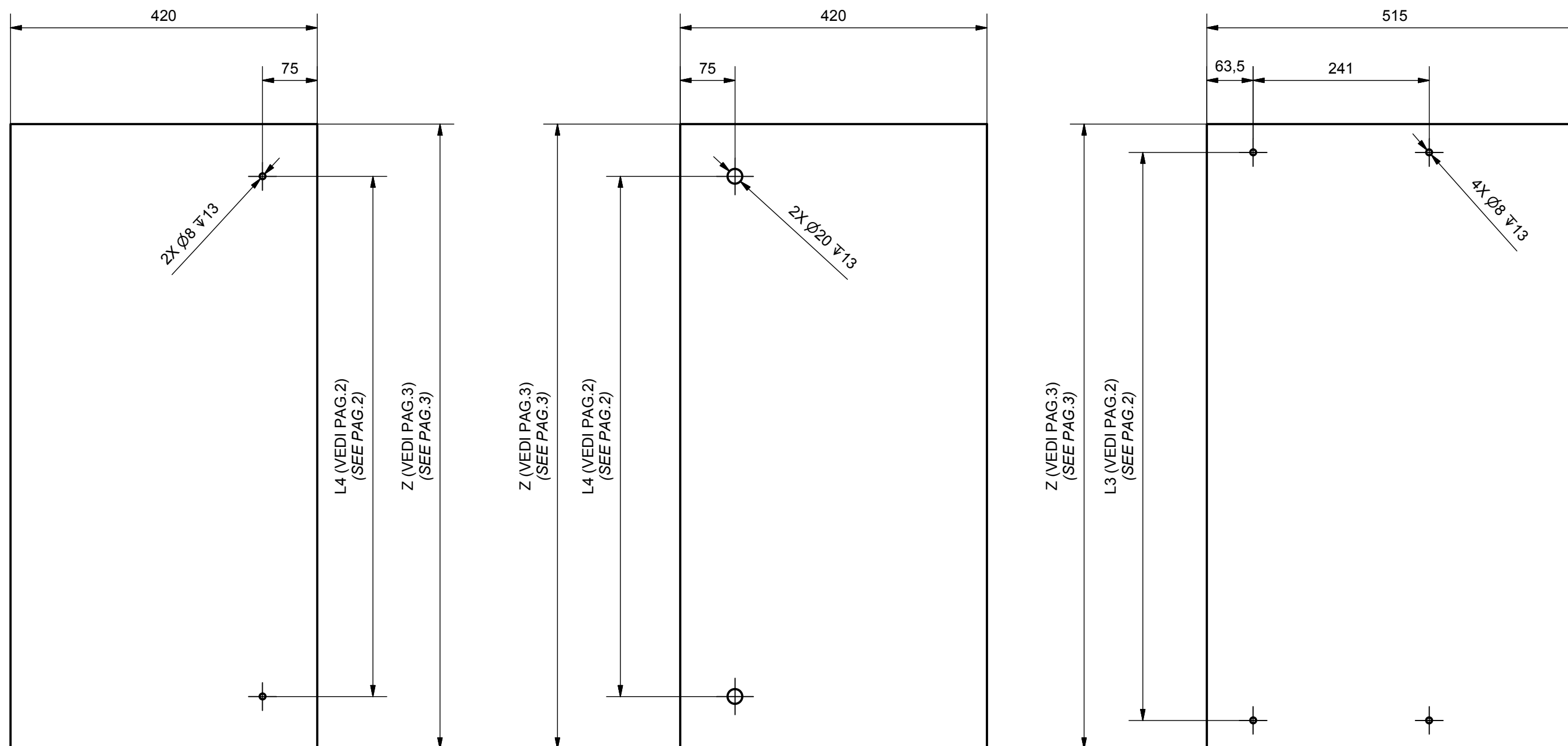

VISTA DAL BASSO - BOTTOM VIEW

MONTAGGIO DEL MECCANISMO SUL MOBILE MOUNTING OF THE MECHANISM ON THE CABINET

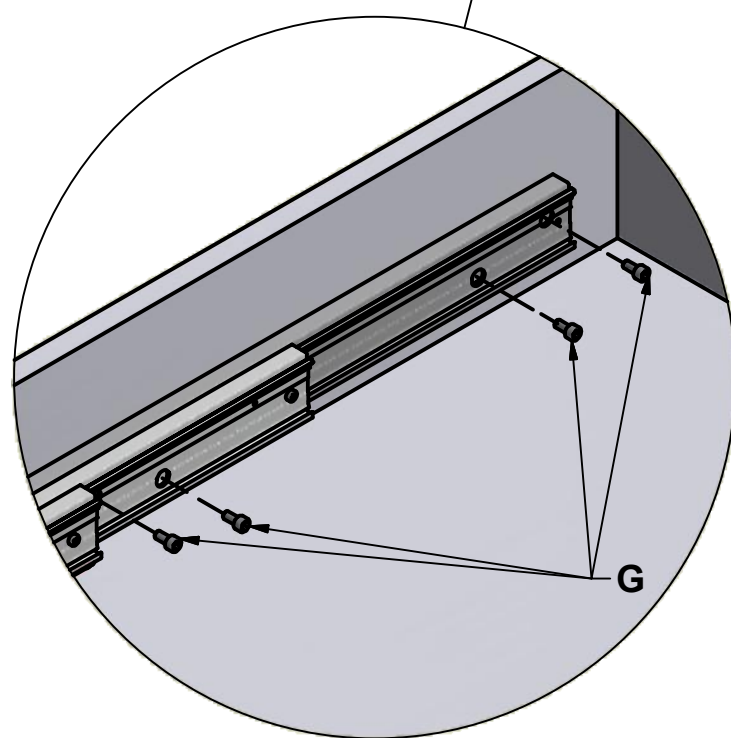
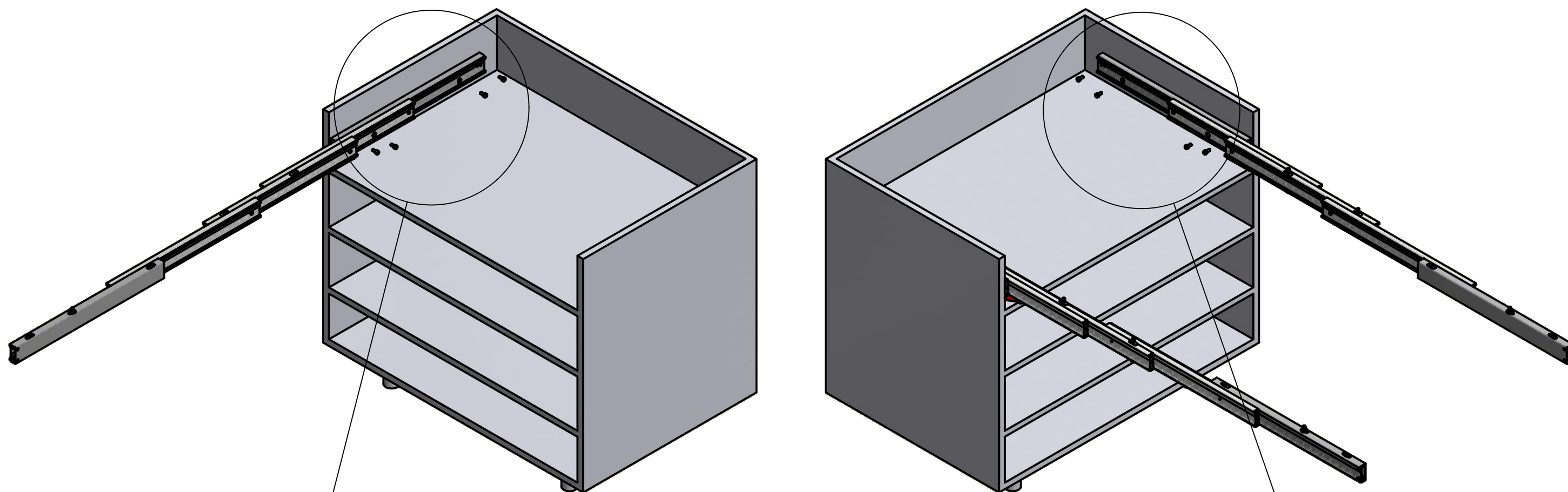

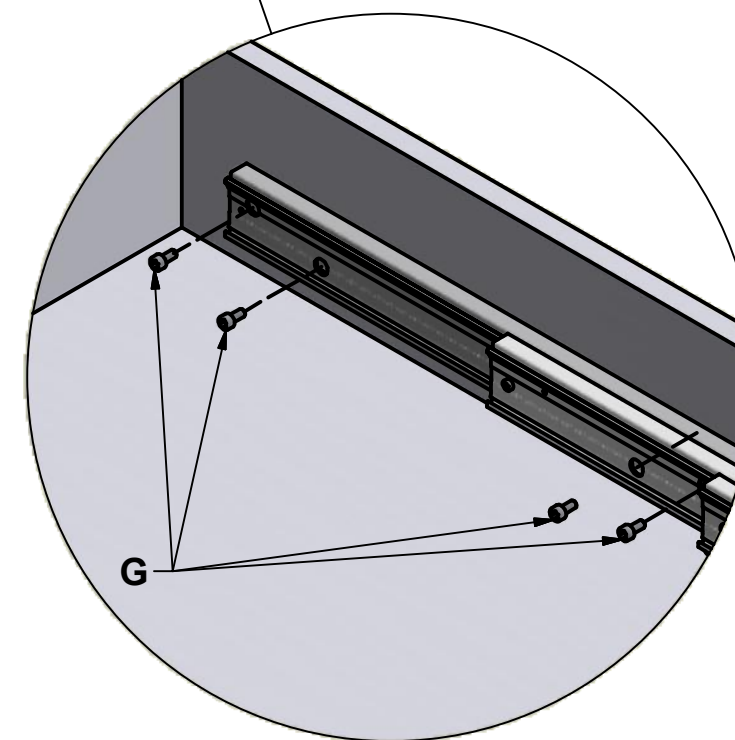

 G. Vite TCCE M6x12 - *M6x12 socked head cap screw (x 4)*

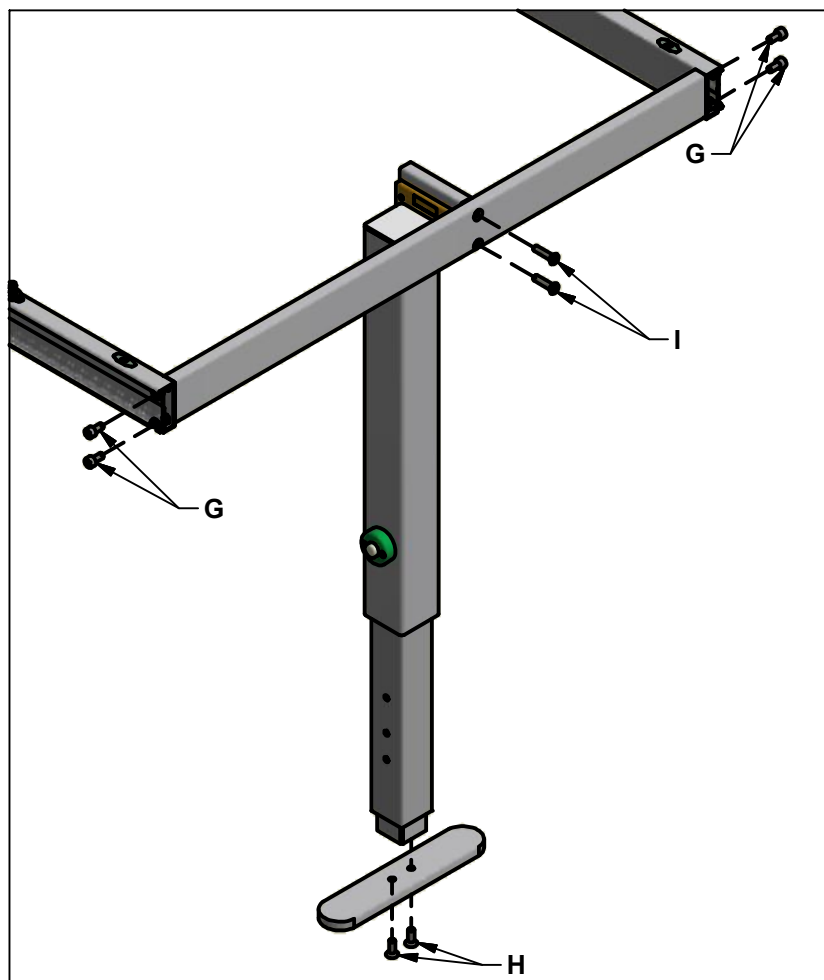
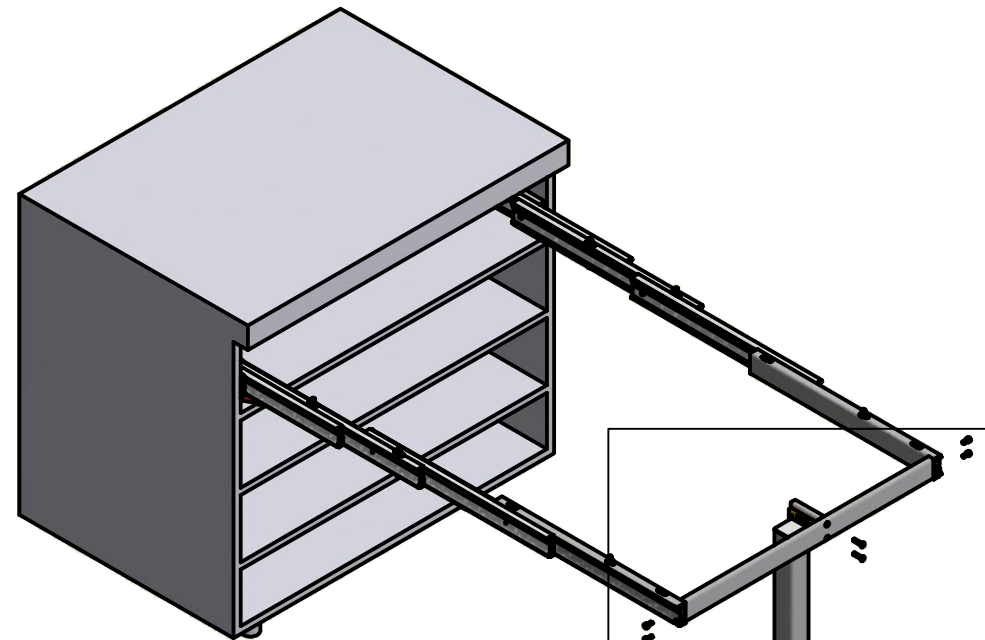

MONTAGGIO DI TRAVERSO, PIATTONE E GAMBE CONNECTION BAR, PLATE AND LEGS ASSEMBLY



-  G. Vite TCCE M6x12 - M6x12 socked head cap screw (x 4)
-  H. Vite TPS M6x16 - M6x16 screw (x 2)
-  I. Vite trilobata M6x25 - M6x25 self threading screw (x 2)

REGOLAZIONE ALTEZZA GAMBA HEIGHT REGULATION LEG

Inserire in questi fori la chiave da 4 per ruotare grano che permette regolazione della altezza della gamba di circa 25 mm

Insert in these holes the n. 4 allen key to allow leg height regulation of about 25 mm

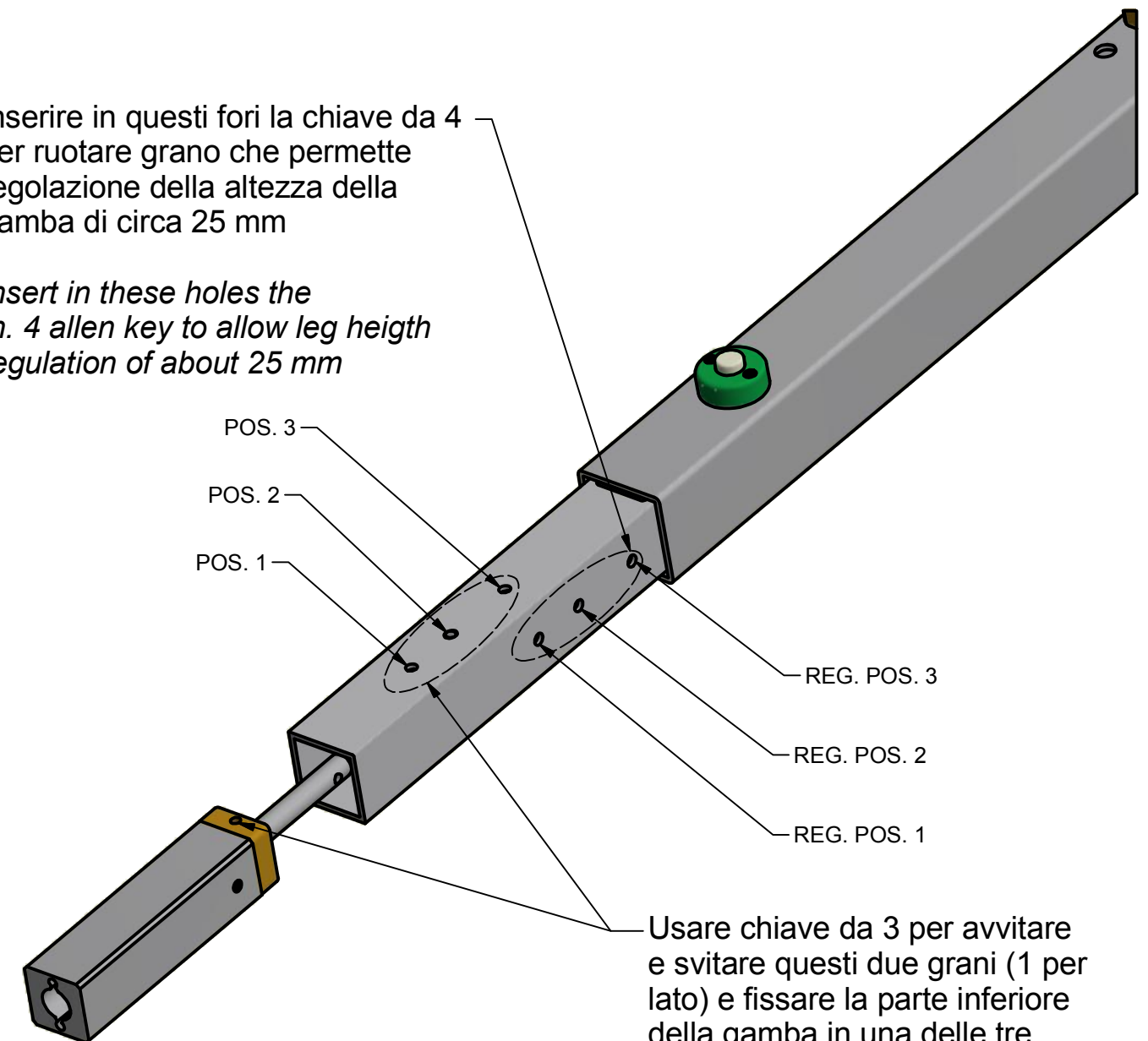

Usare chiave da 3 per avvitare e svitare questi due grani (1 per lato) e fissare la parte inferiore della gamba in una delle tre posizioni disponibili.

Use the n. 3 allen key to screw and unscrew this grain and positioning the lower part of the leg in one of the three allowable positions

PREPARAZIONE E FISSAGGIO DEI PIANI

PLANES ASSEMBLY

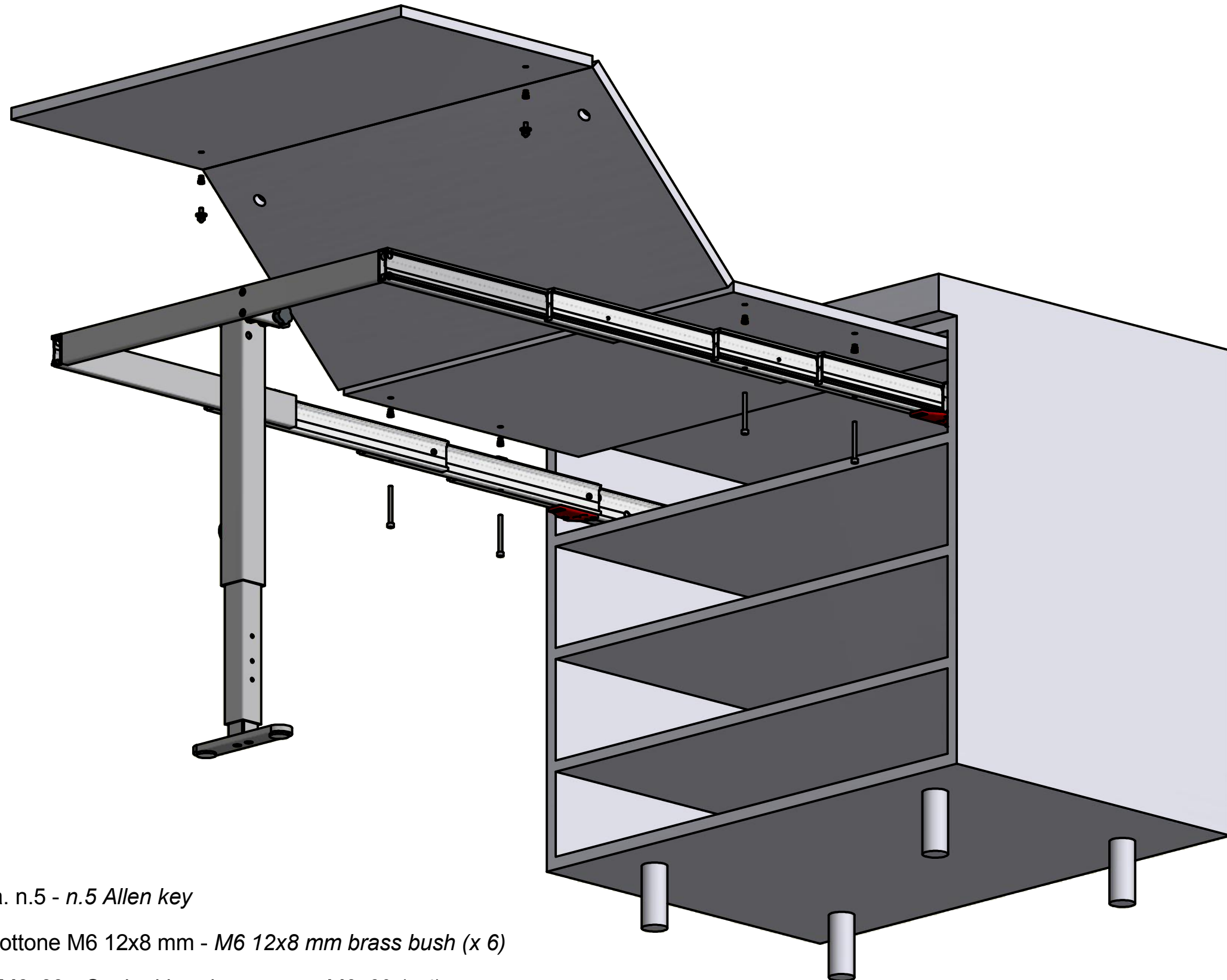

C. Chiave esa. n.5 - *n.5 Allen key*



E. Bussola in ottone M6 12x8 mm - *M6 12x8 mm brass bush (x 6)*



J. Vite TCCE M6x60 - *Socket head cap screw M6x60 (x 4)*



K. Perno blocco piano - *Pin for blocking plane (x 2)*

SEQUENZA DI FUNZIONAMENTO

FUNCTIONING SEQUENCE

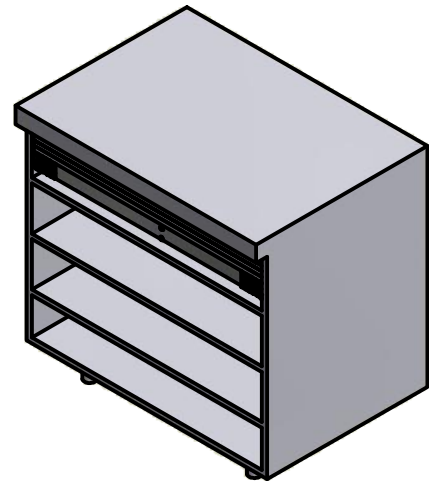

CHIUSO
CLOSED

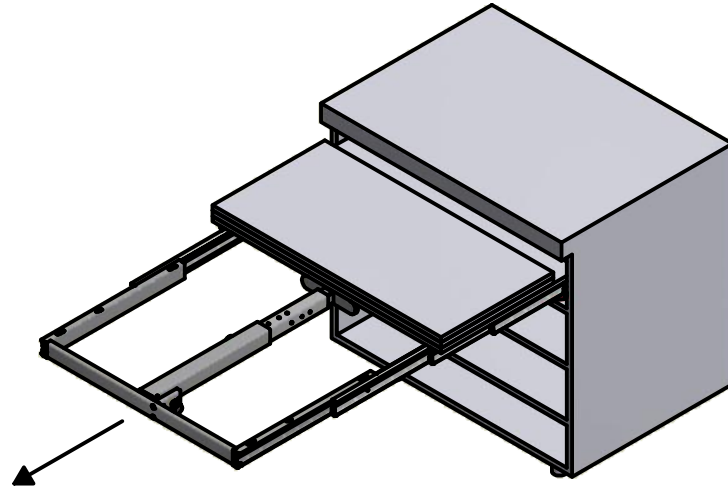

APERTURA DELLE GUIDE
SLIDES OPENING

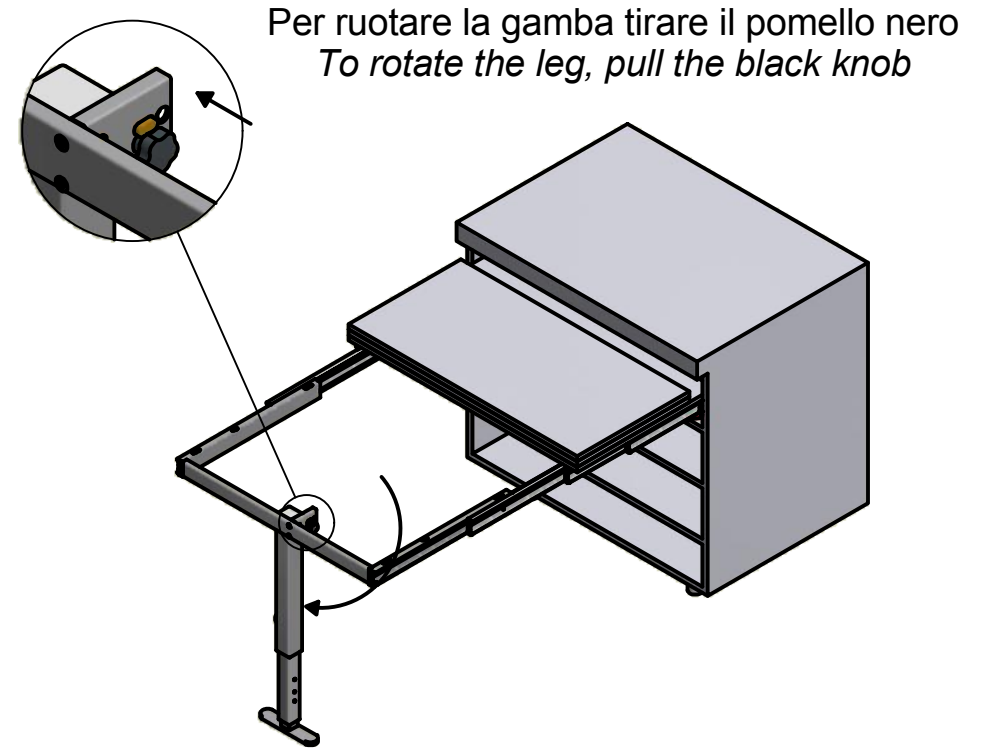

SBLOCCO E ROTAZIONE DELLA GAMBA
LEG RELEASE AND ROTATION

Per ruotare la gamba tirare il pomello nero
To rotate the leg, pull the black knob

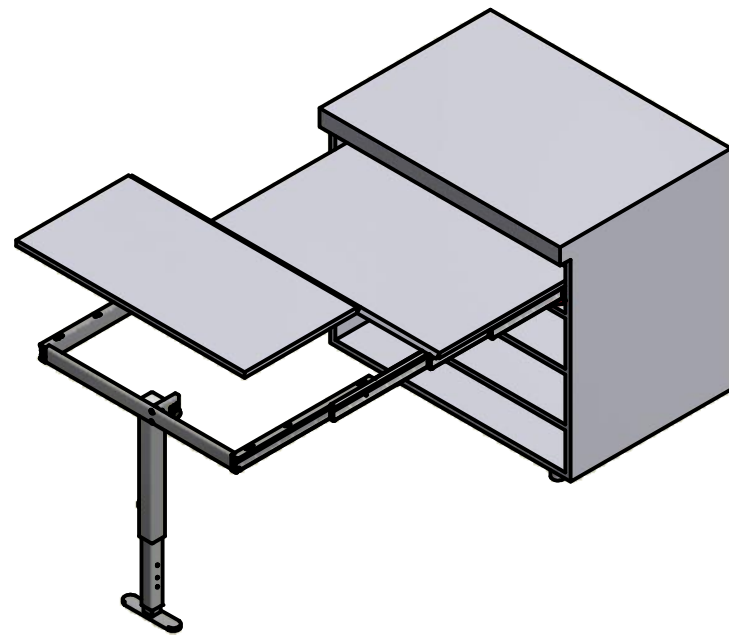

APERTURA DEI PIANI
PLANES OPENING

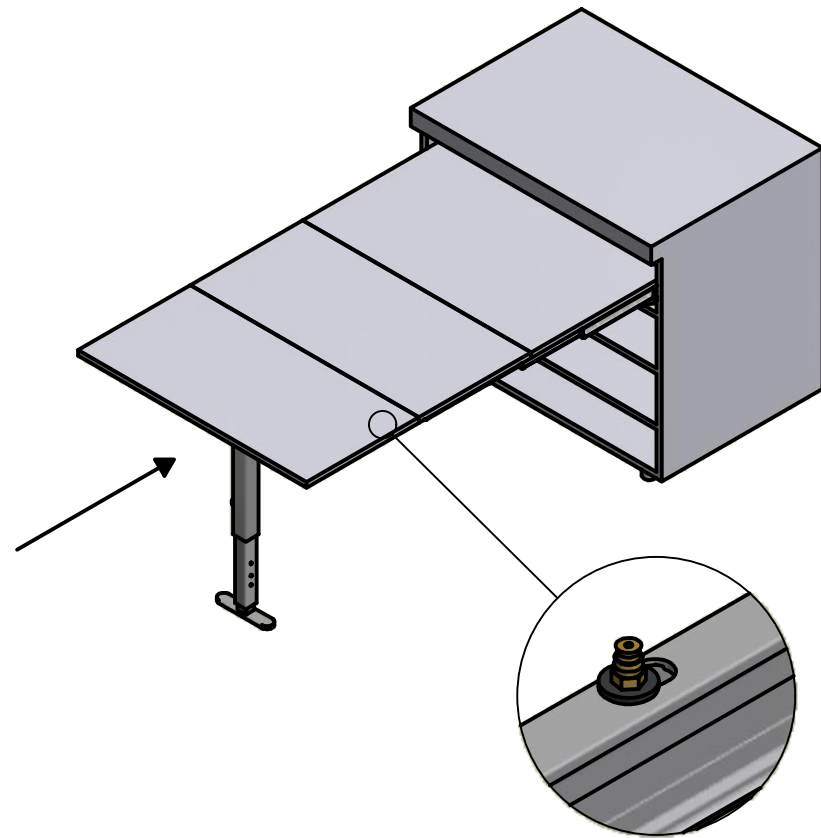

APERTO, SPINGERE LE GAMBE VERSO L'INTERNO
OPENED, PUSH THE LEG TOWARDS THE CABINET

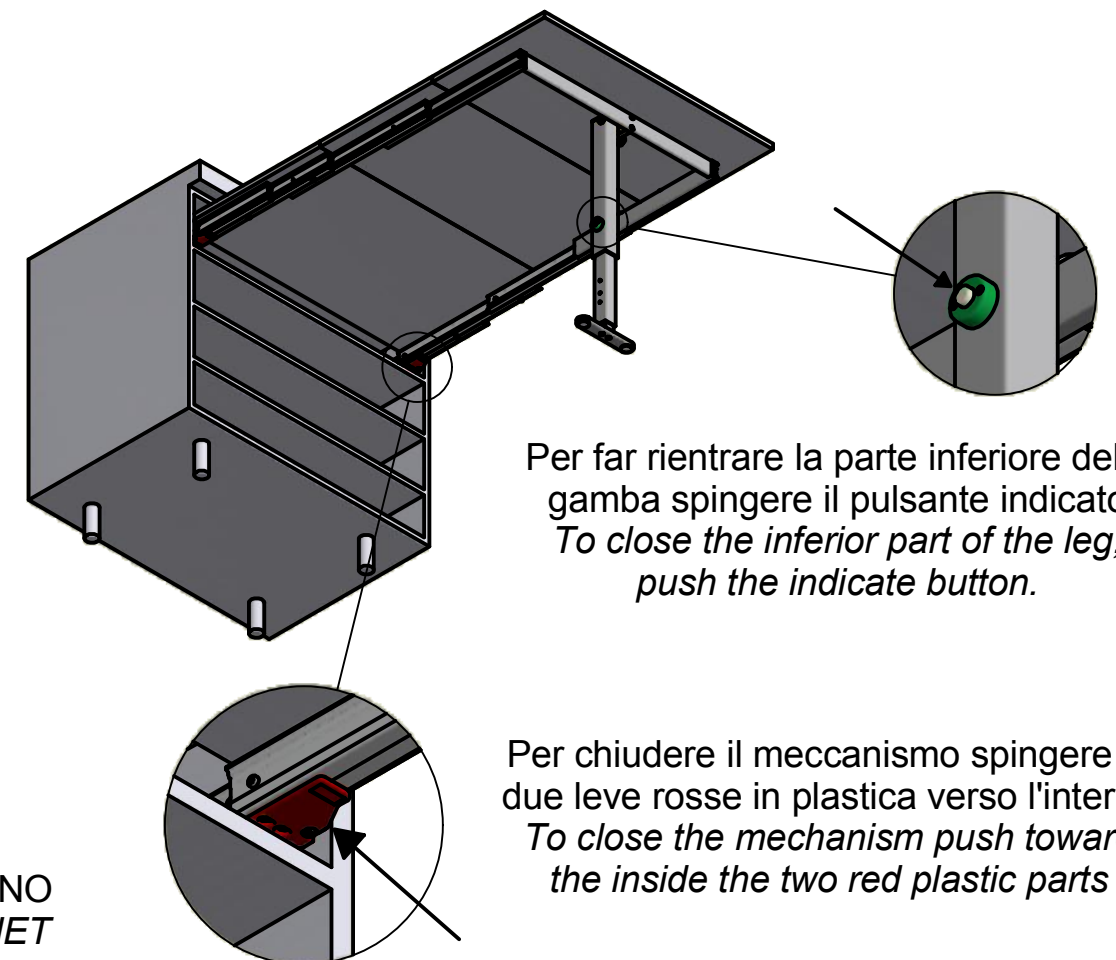

Per far rientrare la parte inferiore della gamba spingere il pulsante indicato
To close the inferior part of the leg, push the indicate button.

Per chiudere il meccanismo spingere le due leve rosse in plastica verso l'interno
To close the mechanism push toward the inside the two red plastic parts