

Vendetta

Version 2.0

Assembly Instructions

support@cruzbike.com



CRUZBIKE

1. General information

General Safety Information

⚠️ WARNING – to avoid serious injuries:

1. If you are unsure about **fitting, testing and adjusting brakes or gearing on a bicycle**, you should take your bicycle to a professional bicycle mechanic for adjustment. Improperly adjusted brakes or drivetrain components could cause severe injury or death.
2. If you are unsure of **the frame assembly instructions**, you should take your bicycle to a professional bicycle mechanic for assembly. An improperly assembled frame could cause severe injury or death.
3. Riding any cruzbike is a learned skill. Be sure to acquire those skills, seeking help and support as needed.

Assembly

This instruction set describes the assembly sequence but there may be minor differences in specification of your model.

Add components following manufacturer's instructions. This document does not describe how to fit components, however the Vendetta frame provides standard mounting points for standard road bike components. Refer to **Page 2, Preparation** before beginning.

Using a stand

The best place to clamp the frame is on the slider tube with the front of the bike up so that the back of the bike hangs down and does not swing. Using a trainer on the front wheel is good for component assembly, and placing bike and trainer on a low bench is also helpful.

2. Preparation

Attend to the following before commencing assembly:

- Unpack the items and unwrap them, except for tube protection which may be retained until the bicycle is ready to be ridden.
- Identify the box containing the headset bearings, (do not unpack them yet).¹
- Identify the frameset is complete, by reference to the parts diagrams on this and the following pages.
- If you do not have all the parts, contact sales@cruzbike.com and provide the part number.
- Obtain a set of metric hex head wrenches (also known as allen keys) in sizes 5mm, 4mm, 3mm and 2mm.
- The chainstay connects to the boom via the bottom bracket bearing cups. The assembly cannot be completed unless you have a bottom bracket bearing set. **Important!** You will also need the special bottom bracket cup wrench to tighten them.
- If the wheel axles don't easily fit the dropouts, use a file to remove excess paint.

¹ If the details of headset are new to you, two of many useful links explaining them are *Sheldon Brown's authoritative glossary* and this *general description with diagrams* that describe the Integrated Headset as found on Vendetta.

| ITEM NO. | PART NUMBER | QTY. |
|----------|--------------------------------|------|
| 1 | VN Main Frame | 1 |
| 2 | VN Fork | 1 |
| 3 | VN Chainstay | 1 |
| 4 | VN Boom | 1 |
| 5 | VN Slider | 1 |
| 6 | VN Dropbars | 1 |
| 7 | VN Seat | 1 |
| 8 | VN Seat Cushions | 1 |
| 9 | VN Headrest | 1 |
| 10 | VN Bearing cups | 2 |
| 11 | QR Short | 1 |
| 12 | VN Boom Clamp | 1 |
| 13 | VN Ruber washer | 8 |
| 14 | VN Headrest Clamp | 4 |
| 15 | QR Long | 1 |
| 22 | ISO 7045 - M5 x 20 - Z --- 20N | 4 |

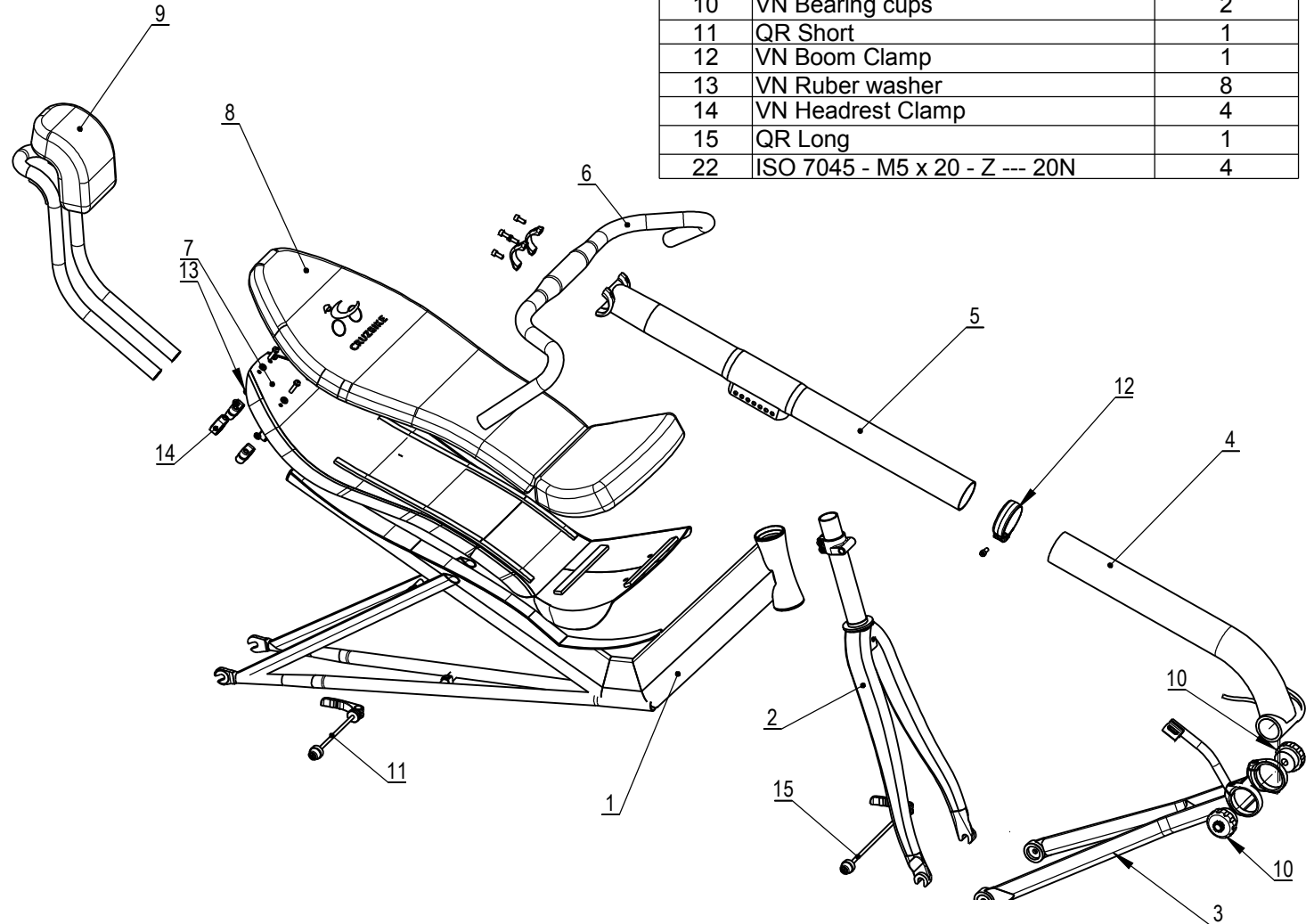

3. Main Frame & Fork

Attach the Seat Shell

- **Important!** The seat shells attach with velcro . If there are holes in the front edge of the seat pan, fit bolts through these holes into the frame.
- Position the seat shell over the frame and smooth down.

Fit the fork

Instead of a stem, Vendetta uses its Pivot Clamp to clamp the headstack. Separate the lower bearing parts from the upper.

Place the lower ones over the fork steerer, the lowest piece is a silver split ring that spreads over the base of the fork steerer.

Place the fork steerer into the frame, then slide the upper bearing stack onto it.

Place the spacers and the Pivot clamp over the fork steerer, making sure the Pivot Clamp clears the top of the fork neck by up to 1/8" or 3mm. Then add the cap, and tighten the cap bolt.

Tighten the bearing stack. Make the two Pivot Clamp bolts finger tight. (Later, after the Front Triangle is added, tighten the two Pivot Clamp bolts.)

Attach the Headrest

Add the four plastic clamps to the headrest tube. The top pair point in, the lower pair point out. The nut side of the clamp points down.

Fit the four bolts through the seat back and place two rubber bushings over each bolt to

cushion between the seat shell and the clamp. Then slide the headrest into the clamps. Using the hex key in your fingers, make the bolts firm.

Place two small pieces of Velcro in the crease of the headrest tube (at 'A'.), to hold the headrest cushion, which slides over.

Fit the cushions

Stick the velcro strips to the Seat Back and Seat Pan, as shown.

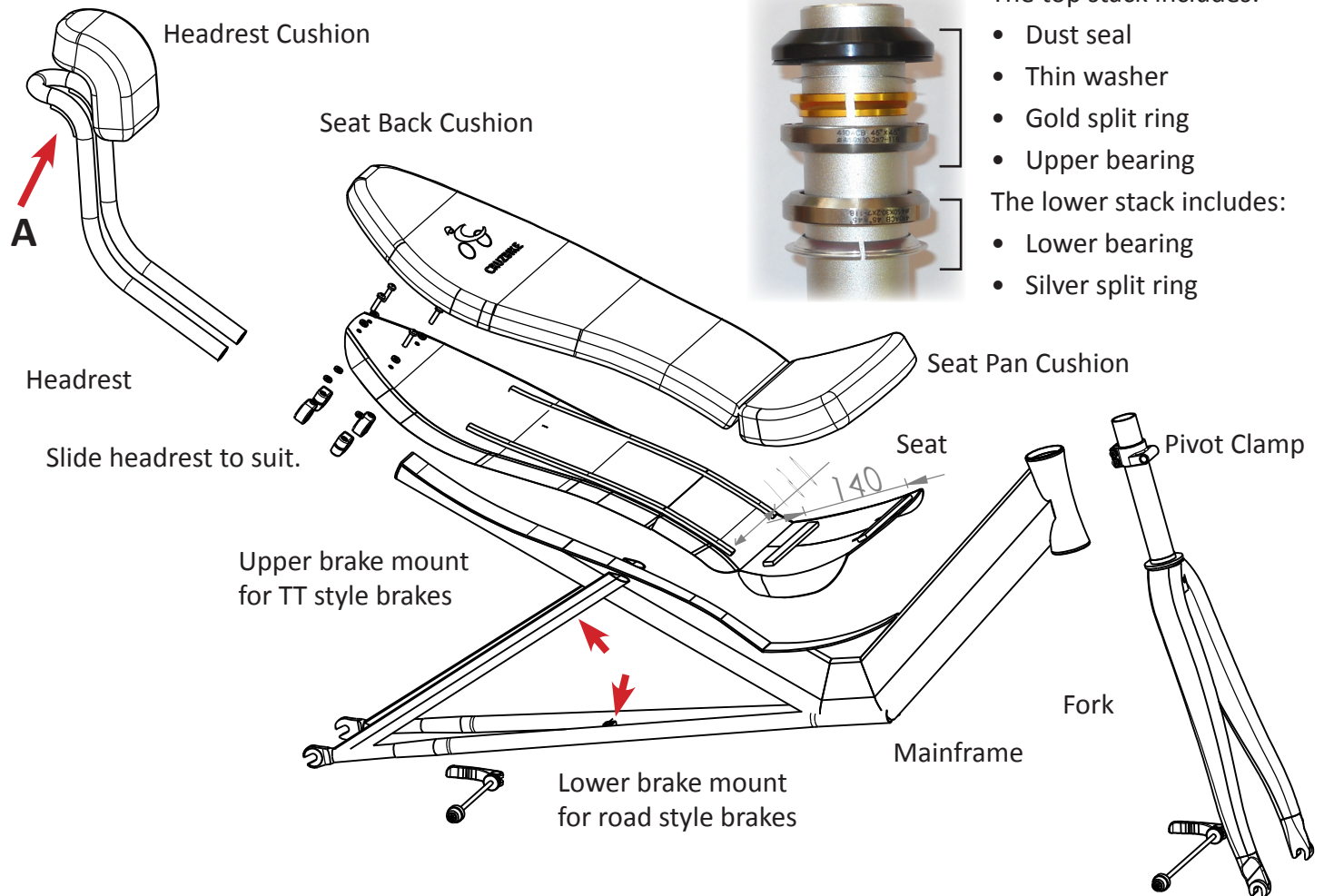

4. Front Triangle

Fit the Boom to the Chainstay

To do this step, you need to have the bottom bracket bearing cups. **Important!**

- Place the Chainstay on the bench and hold the Boom in place,
- Thread the bottom bracket bearing cups in each side, working through the chainstay ring and into the bottom bracket shell.
- Slide the Chainstay rings away to the right to tighten the left bearing cup. Repeat for the other side. Tighten the bearing cups to manufacturer's specification with the appropriate tool.
- Make the Chainstay Ring clamp bolts finger tight only. Back each bolt off half a turn. **Important - we need this to rotate during adjustment!** (Fully tighten the Ring Clamp bolts after sizing adjustment.)

Fit RD Hanger & Slider

Insert the RD hanger to the inside of the right Chainstay dropout. Optionally fix with Cyanoacrylate (Supa glue).

Add the Boom Clamp to the Boom, insert the Slider and tighten the boom clamp until the slider is a light sliding fit.

Connect the Front Triangle

Gently spread the chainstay legs apart and fit the dropout housings over the lugs on the fork dropouts.

Lower the Slider Cage over the Pivot Clamp and fit the Pivot Clamp Pin to the forward

post pair of holes in the Pivot Cage. Fit the handlebars.

The following clamps must be tightened:

- Boom Clamp;
- Pivot Clamp Pin;
- Pivot Clamp Bolts;

- Chainstay ring clamps - make sure boom is centred between chainstay ring clamps; and

- Front wheel quick release.

Preparing the FD cable loop

The front derailleur cable should loop the Bottom Bracket in a gear

cable housing of about 250mm, the cable enters the top, runs over and underneath the BB, and through the gap between the BB and chainstay:

This completes the frame assembly. The bike is now ready for standard road bike components to be added.

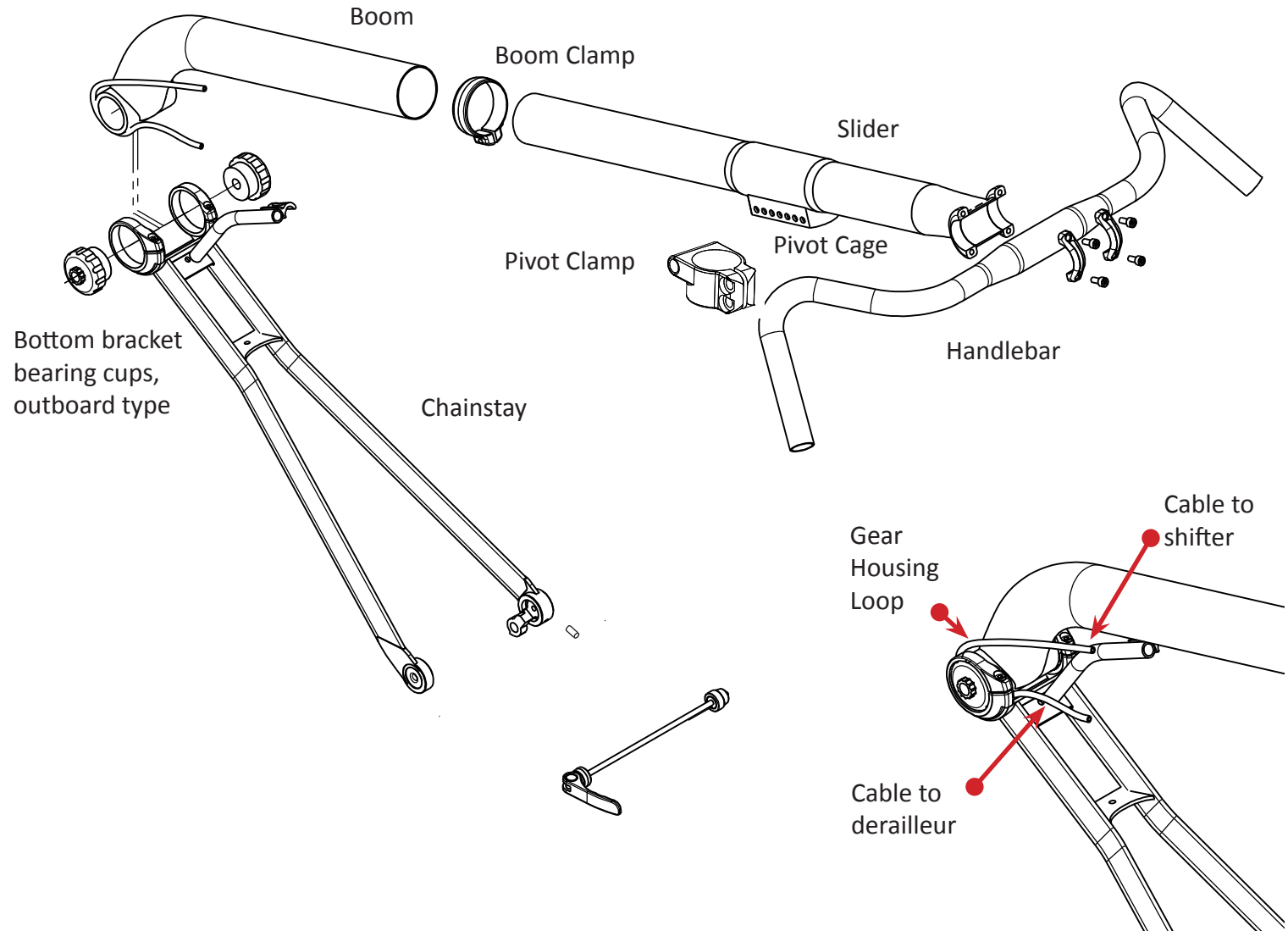

6. Fit to Rider

Add a pair of wheels and a crankset and fit the bike to the rider.

Adjust the leg reach. Have the rider put their heel on the pedal with an extended leg, and tighten the boom clamp in that position.

After several weeks riding, decide if the bars should be moved further forward. Do this adjustment where the Pivot Clamp connects to the Pivot Cage. You can also choose how many spacers to have above and below the pivot clamp.

The following are loosened and tightened as required:

- Chainstay Ring Clamps
- Front wheel skewer
- Boom Clamp
- Pivot Clamp Pin
- Pivot Clamp Bolts

Vendetta comes in three frame sizes. There is some overlap between the sizes.

| C-Seam | Small | Medium | Large |
|--------------------|-------|--------|-------|
| minimum | 710 | 815 | 930 |
| maximum | 855 | 970 | 1085 |
| range | 145 | 155 | 155 |
| overlap | 40 | 40 | |
| X-Seam | | | |
| if crank length is | 160 | 165 | 175 |
| minimum | 870 | 980 | 1,105 |
| middle | 943 | 1,058 | 1,183 |
| maximum | 1,015 | 1,135 | 1,260 |

C-Seam means distance from the seat back to the

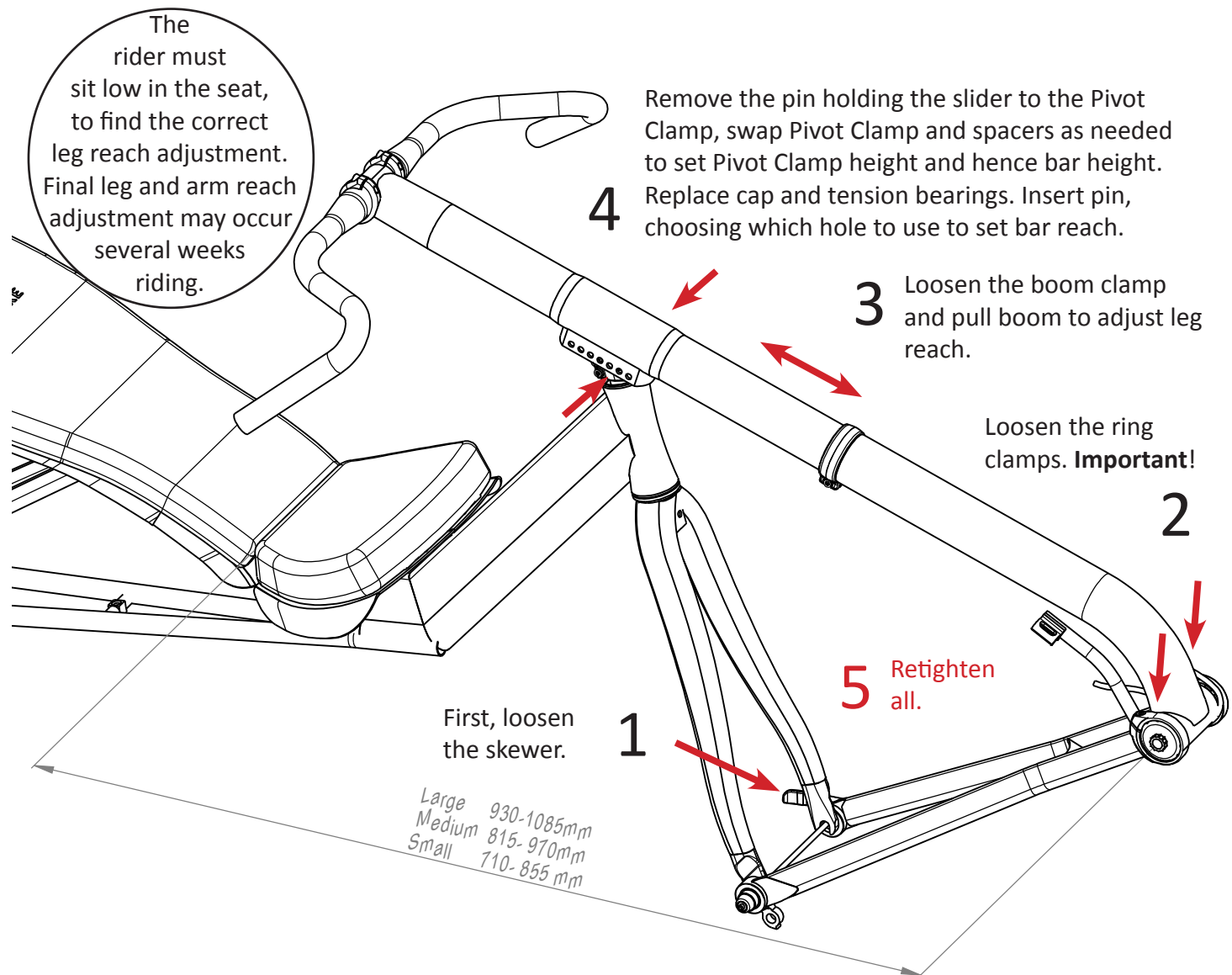

center of the Crank axle.

X-Seam means distance from the seat back to the centre of the pedal spindle.

Additional discussion on choosing the correct frame and handlebar shape is found here: <http://cruzbike.com/how-choose-your-vendetta-setup>

Component assembly

Adjust to the rider before running the cables. Do not trim the FD cable, in case additional length is needed when fully adjusted to the rider.

All components should be assembled according to their manufacturer's instructions.