

Owner's Manual

Powerhouse Quartz Dryer



Table of Contents



I. Introduction	3
II. Specifications	4
III. Parts for Assembly	5
IV. Safety Procedures	6
V. Assembly	
Step 1: Leveling the Dryer and Installing the Legs	7
Step 2: Attaching the Support Struts	10
Step 3: Attaching the Outfeed	11
Step 4: Attaching the Infeed	12
Step 5: Installing the Belt	13
Step 6: Adjusting the Belt Tracking System	14
Step 7: Installing the Reflectors	15
Step 8: Connecting to the Engine	16
VI. Elements	17
VII. Controls	18
VIII. Recirculation System	19
IX. Ventilation	20
X. Temperature Control Programming	21
XI. Wiring Diagram	23
XII. Limited Warranty	34

Introduction



Congratulations on your purchase of the Powerhouse Quartz Dryer.

Check the crate for damages. DO NOT accept the crate if there are any damages caused by improper handling during shipping. Immediately report any damages to the carrier and contact Workhorse Products at, 800-778-8779.

Be sure to inspect the crate contents IMMEDIATELY, while the carrier is still present. Even though our packaging has been designed to handle normal shipping conditions, we cannot foresee damages done by the carrier. We will not be responsible for damages that occur during transportation.

If there are damages immediately notify the driver, file a claim with the carrier and call Workhorse Products.

The Importance of the Owner's Manual:

The purpose of the Owner's Manual is to familiarize you with the parts and operations of the Powerhouse Quartz Dryer. There are step-by-step instructions to assemble the product, explanations of the product's key features, and additional information that will help with the maintenance of the product.

Specifications



PQ-2608 Belt Size: 26" x 8'
Production Capacity: 200-300/hr.
Dimensions: 96"x 41"x 32"

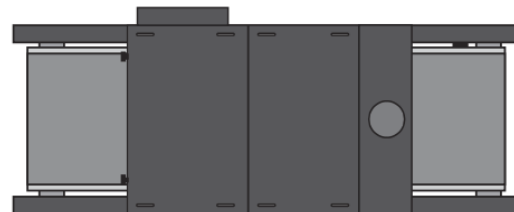

PQ-3011 Belt Size: 30" x 11'
Production Capacity: 400-500/hr.
Dimensions: 132"x 41"x 32"



PQ-5208 Belt Size: 52" x 8'
Production Capacity: 400-500/hr.
Dimensions: 96" x 60" x 32"

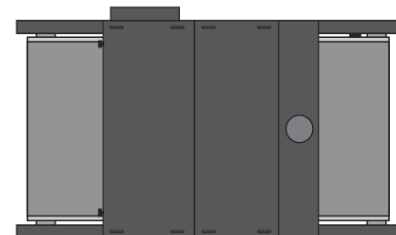

PQ-4013 Belt Size: 40" x 13'
Production Capacity: 600-800/hr.
Dimensions: 156" x 50" x 32"

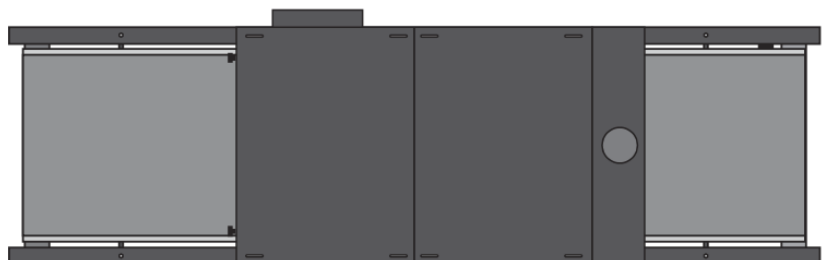

PQ-5217 Belt Size: 52" x 17'
Production Capacity:
1000+/hr.
Dimensions: 204" x 60"x32"

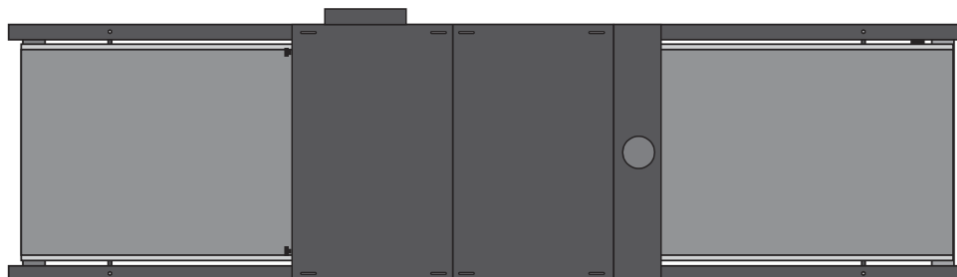

Parts for Assembly



QTY	Description	Part Number
1	Dryer Body	Pre-Assembled
1	Belt (2608)	20936
16	Flange Nuts	42-FLG-3125-10
16	Hex Bolt (1/4-20x 1/2")	41-HB-250-15
16	Hex Bolt (5/16-18x 3/4")	41-HB-3125-10

QTY	Description	Part Number
2	Cross Braces	2608
6	Reflectors	82118
1	Treading Pin	99-2375
8	Hex HD Bolt (1/4-20" x 2-1/2")	41-HB-250-95
16	Lock Washer	43-LOK-250-30
38	Flat Washer	43-FLT-250-30

The part numbers will differ depending on the specific model being assembled. In this manual a 2608 Powerhouse Quartz dryer is being assembled. **The part number will not match if assembling another model of the product.**

WARNING!

RISK OF ELECTRICAL SHOCK! Turn ALL power to unit OFF before service.

All service should be done by or under the supervision of a trained technician

1. For your safety, do not store or use gasoline or other flammable vapors and liquids in the vicinity (at least 3' (1 Meter)) of this or any other appliance.
 2. Vent lines to the outdoors must be installed by a qualified HVAC engineer on all air exhaust and gas line components equipped with a vent fitting.
 3. Proper grounding (a ground rod at the equipment footing), according to NEC requirements, must be provided for during electrical connection by a **QUALIFIED ELECTRICIAN**.
 4. Never alter the internal wiring of this machine.
 5. Never place any item other than the stock to be cured or dried on this dryer's conveyor belt. Do not overload the belt.
 6. Do not let the conveyor belt track off the conveyor drive rollers.
 7. Keep all loose articles (including clothing, hair, jewelry, etc.) away from the conveyor belt.
 8. Never leave the machine unattended when it is operating.
 9. Do not perform maintenance on this machine until all power has been shut off at the dryer **AND** at the incoming power circuit breaker.
-

THIS ELECTRIC DRYER IS INTENDED SOLELY FOR THE PURPOSE OF CURING INK ON TEXTILE AND CUT GOODS. THIS DRYER IS NOT INTENDED FOR USE IN HEATING, CURING OR BAKING OF ANY OTHER MATERIALS.

THIS DRYER IS INTENDED FOR INDOOR USE ONLY



THE EXCLAMATION WITHIN AN EQUILATERAL TRIANGLE SYMBOL IS INTENDED TO ALERT THE USER OF IMPORTANT SAFETY PRECAUTIONS TO BE AWARE OF DURING OPERATION.

Step 1: Leveling the dryer and installing the legs.

Tools needed:	Parts needed:	
• 9/16" Socket Wrench	• Dryer Base	• 8 x Flat Washers
• 9/16" Wrench	• 8 x Lock Washers	• 12 x Hex Bolts (5/16-18" x 3/4")
		• 12 x Flange Nuts

1. Install a hex bolt into the "J" located on the leg, which is on the pre-assembled base.

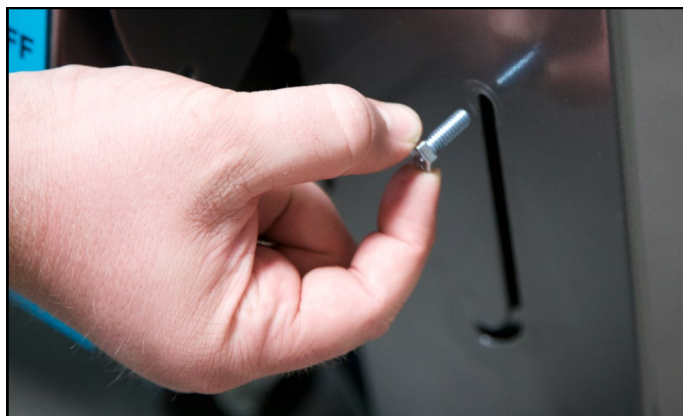

2. Thread a lock nut onto the other side of the bolt, which is located inside of the dryer. Make sure the nut is very loose, because the bolt has to be able to move when the base is lifted.

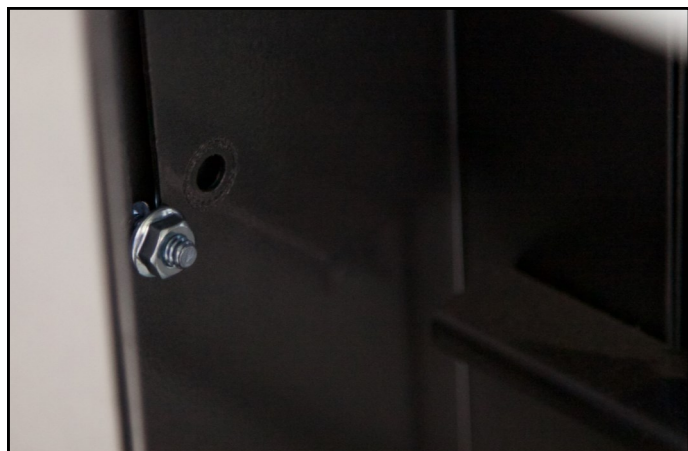

Repeat steps 1-2 for the other leg on the same side.

3. Using two people, lift the dryer to expose the leg. The bolt will fall to the very bottom of the "J" where a third person will tighten it. Use a 9/16" socket wrench on the bolt and a 9/16" wrench on the nut.

The two people holding the dryer will continue holding the same side up, so the third person can repeat steps 1 and 2 for the other leg on the same side.



Step 1 (Continued): Leveling the dryer.



4. With the side of the dryer still lifted, tighten the bolt and nut for the other leg.

5. At this point, only one side of the dryer will be leveled. Just like steps 1-2, insert a bolt and nut loosely into the “J”.

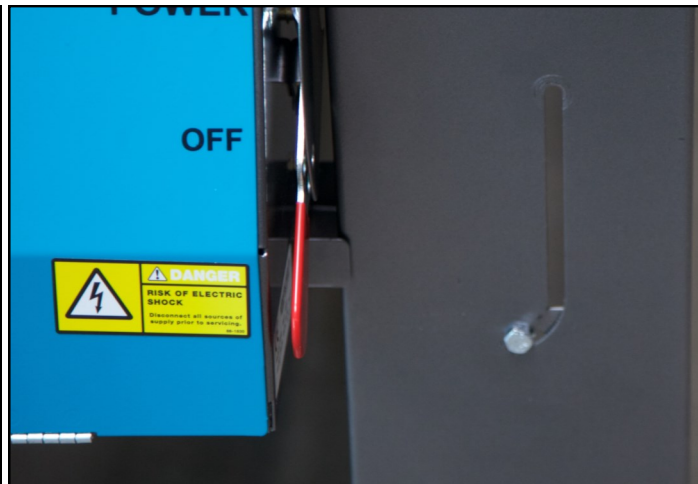

6. With two people lifting, let the bolt fall to the bottom of the “J” and the third person tightens the nut and bolt with a socket wrench and a wrench.

Insert the bolt and nut into the other side while the dryer is still lifted. Tighten the last leg.

7. The dryer is leveled after all four legs have been tightened. The bolt should be at the bottom of the “J”, just like in the photo above.

Step 1 (Continued): Installing the legs.

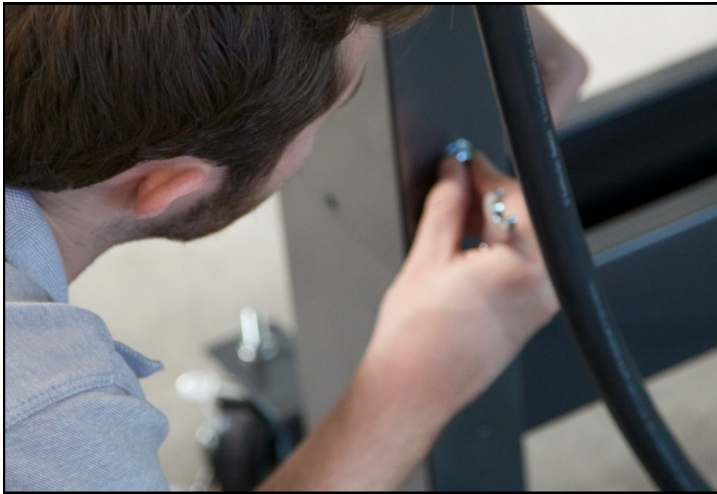

8. Insert a 1/2" washer, lock washer and hex bolt (5/16-18"x 3/4") into the side panel on the side of the leg.



9. Tighten a 5/16" flange nut onto the other side of the bolt located inside of the dryer. Tighten the bolt and nut with a socket wrench and wrench. Repeat steps 8-9 for the other side panel on the same leg.



10. Repeat steps 8-9 for the other three legs. In total eight holes should be filled with the designated nut and bolt.

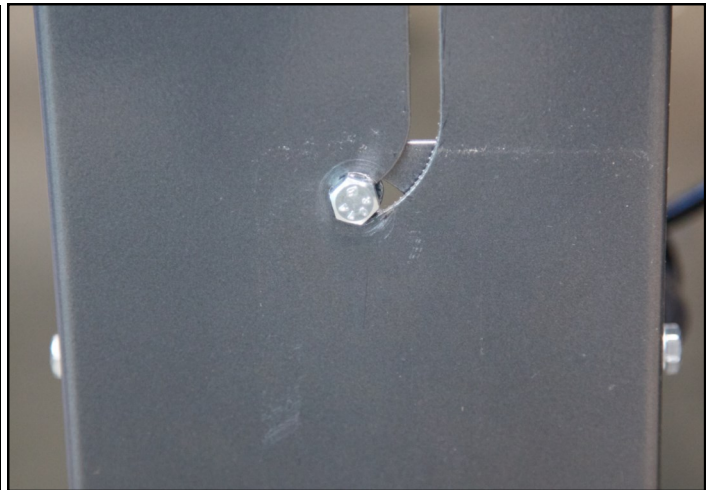

11. At this point the legs should match the photo above. The "J" and the two side panels should be installed for every leg.

Step 2: Attaching the support struts.

Tools needed:

Parts needed:

- 7/16" Wrench
- 7/16" Socket
- 2 x Support Struts
- 4 x Hex Bolts (5/16-18" x 3/4")
- 4 x Lock Washers
- 4 x Flat Washers
- 4 x Flange Nuts



1. Remove the bolt at the bottom of the "J" using a 7/16" socket wrench.



2. Align a support strut with the hole at the bottom of the "J" where the bolt originally was, and the second hole below it.



3. Reinsert the hex bolt with a lock washer and flat washer into its original position at the bottom of the "J", which will be the top of the strut.



4. Tighten a flange nut onto the other side of the bolt located in side of the dryer. Install the other hole on the bottom of the strut. Then install the other end to fully install the strut.

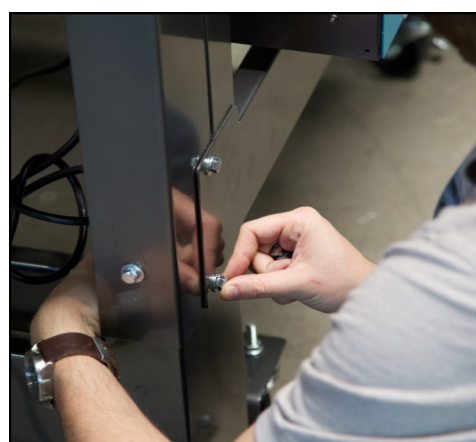

5. Repeat steps 1-4 to install the other strut onto the other side of the dryer. There should be a strut on the front side and the back side of the dryer.

Step 3: Attaching the outfeed.

Tools needed:

- 7/16" Socket Wrench

Parts needed:

- Outfeed Arm
- 8 x Hex Bolt (1/4-20 x 1/2")
- 8 x Flat Washers

1. The outfeed arm (with the belt motor) belongs on the left side of the dryer. With another person, lift the arm and slide it into the dryer while aligning the four holes.



2. While still holding the outfeed arm, thread a hex bolt (1/4-20 x 1/2") with a flat washer into all four of the holes.



3. Tighten all four holes with a 7/16" socket wrench. Repeat steps 1-3 for the other side of the arm on the other side of the dryer.



Step 4: Attaching the infeed.

Tools needed:

- 7/16" Socket Wrench

Parts needed:

- Infeed Arm
- 8 x Hex Boles (1/4-20 x 1/2")
- 8 x Flat Washers

1. The infeed arm (without the belt motor) belongs on the right side of the dryer. With another person, lift the arm and slide it into the dryer while aligning the four holes.



2. While still holding the infeed arm, thread a hex bolt (1/4-20 x 1/2") with a flat washer into all four of the holes.



3. Tighten all four holes with a 7/16" socket wrench. Repeat steps 1-3 for the other side of the arm on the other side of the dryer.

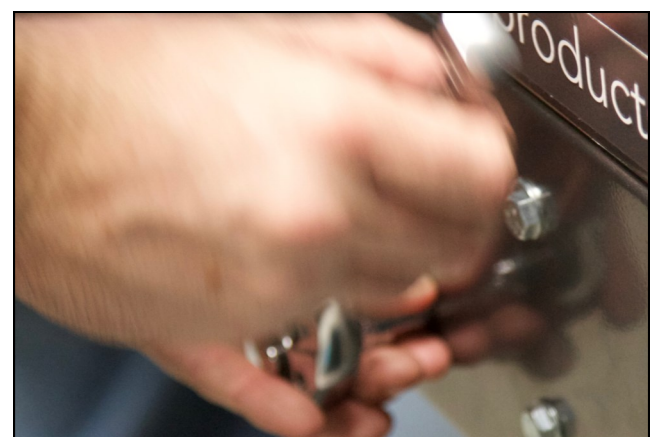

Step 5: Installing the belt.

Parts needed:

- Belt
- Threading Pin

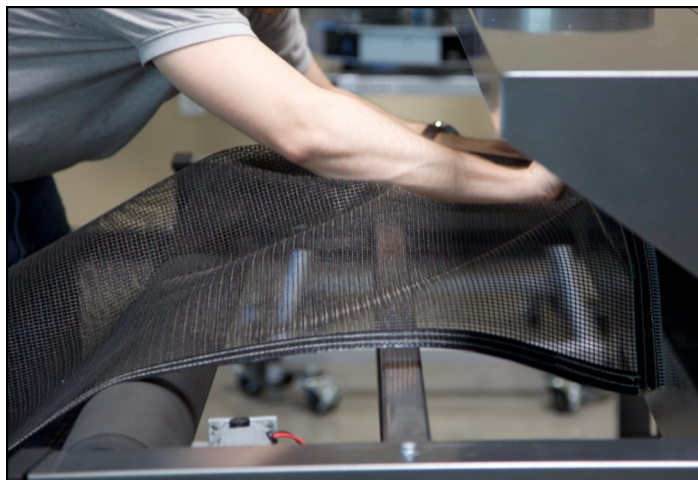

1. Thread the belt over the top of the outfeed roller and over the upper cross brace. After the belt has gone through the chamber, pull the belt to hang over the infeed roller to add weight to help with the threading of the lower portion.



2. On the outfeed side, take the other end of the belt and thread it under the outfeed roller and under the lower cross brace, through the lower slot on the roller/rail assembly. Guide the belt through the oven chamber so it continues through the lower slot and over the lower cross brace.

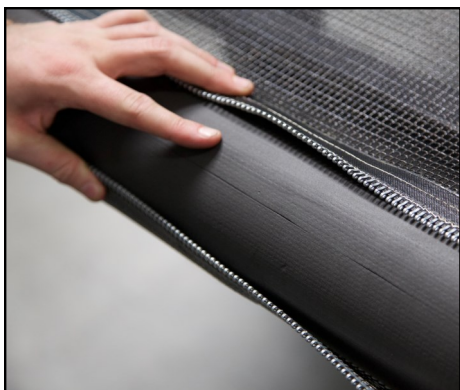

3. Thread the belt until both ends meet on the infeed roller.



4. To install the belt it may be required to adjust the belt tracking. This is done by turning the tension bolt clockwise (to tighten) or counterclockwise (to loosen). Belt tracking will be explained more in-depth on page 13.

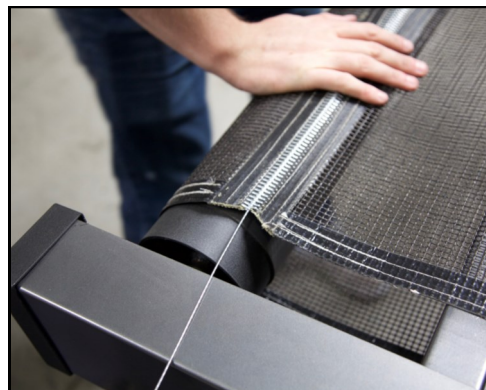

5. Align the belt closure until the teeth mesh connect, and install the threading pin into the teeth. Hold together the teeth while installing the pin. When it's fully inserted and the belt is fully installed, trim any extra pin that may be jutting from the sides.

Step 6: Adjusting the belt tracking system.

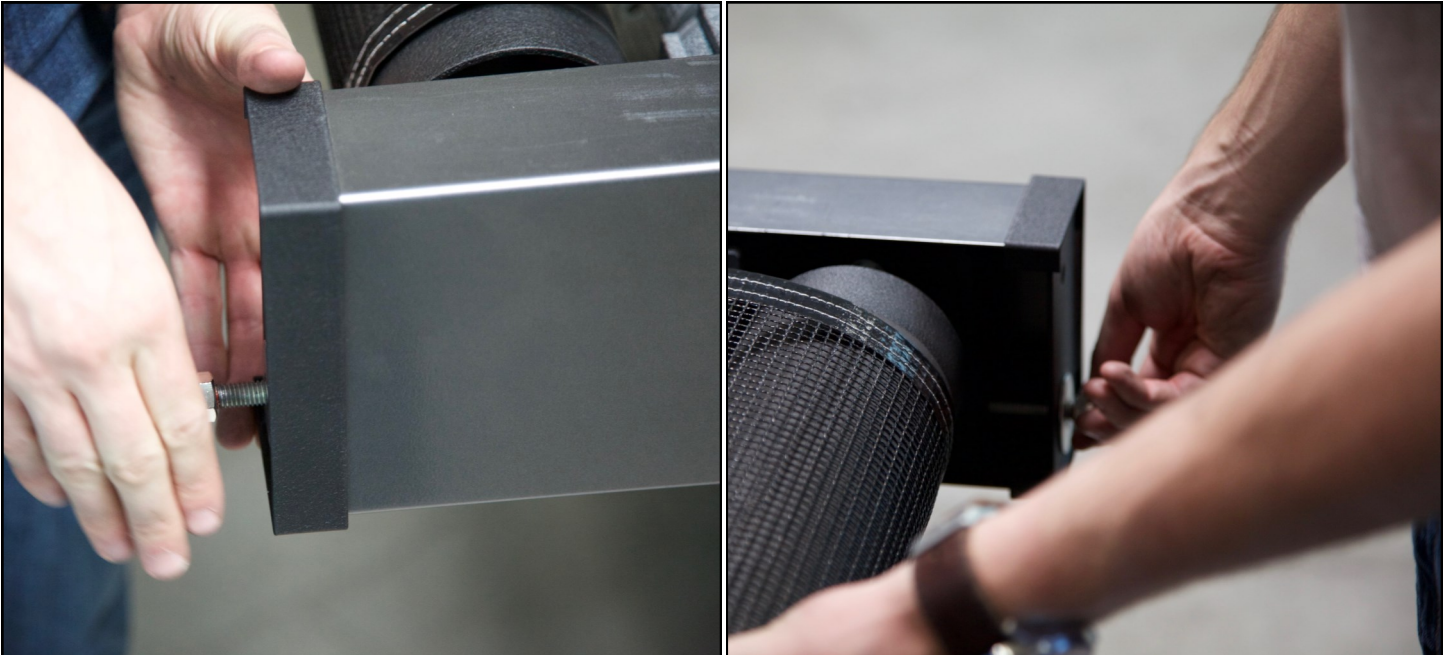

After the belt is centered on the rubber portion of the rollers, evenly adjust the tension bolts on every corner of the dryer to tighten the belt until it can be deflected by about 2 inches. Turn the dryer on and set the belt speed to 35%, as the belt moves make small adjustments to maintain the belt to be in the center of the rollers. Turn the tension bolts clockwise to tighten the belt in that corner, or turn the bolt counter-clockwise to loosen the belt in that corner.

- If the belt is tracking to the right, turn the tension bolt clockwise in 1/4 increments.
- If the belt is tracking to the left, turn the tension bolt counter-clockwise in 1/4 increments.
- Continue using the right and left tension bolts until the belt is centered.

Adjusting the belt to be centered is critical to prevent premature wear of the motor and the belt. In cases where too much belt tracking has caused the belt to become too tense, it is necessary to reset the tension bolts and start over. **DO NOT OVER TENSION THE BELT.**

Step 7: Installing the reflectors.

Tools Needed: Parts Needed:

- 7/16" Socket Wrench
- 6 x Heat Reflectors
- 8 x Hex HD Bolt (1/4-20" x 2-1/2")
- 8 x Flat Washers

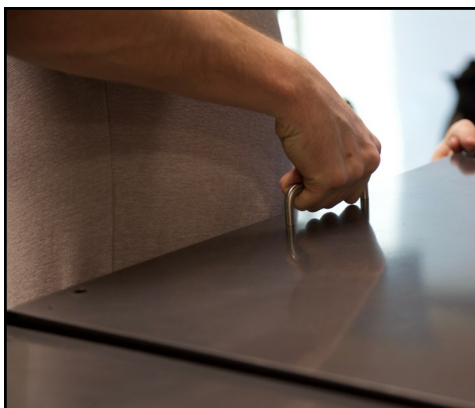

1. With another person, lift the covers to expose the quartz elements. Remove all of the packaging and insulation off of the elements, because they could be a potential fire hazard. **DO NOT TOUCH THE ELEMENTS.**

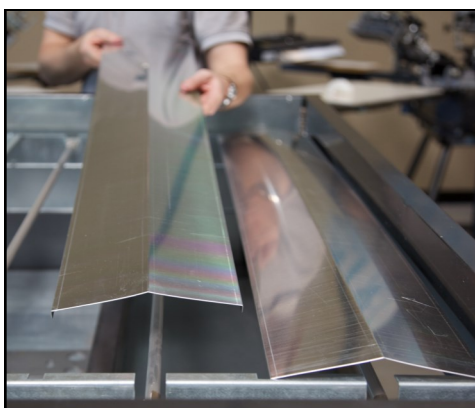

2. Place a reflector over every element. The element fits into the notches that are on the sides of the dryer.

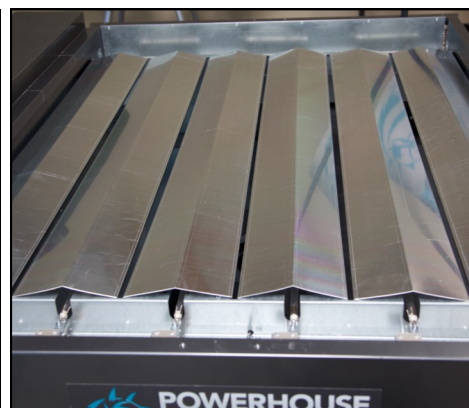

3. Place all six reflectors over all six elements.



4. With another person place the covers back on top of the dryer.



5. Insert a hex bolt (1/4-20" x 2-1/2") and a washer into all eight holes on the cover.

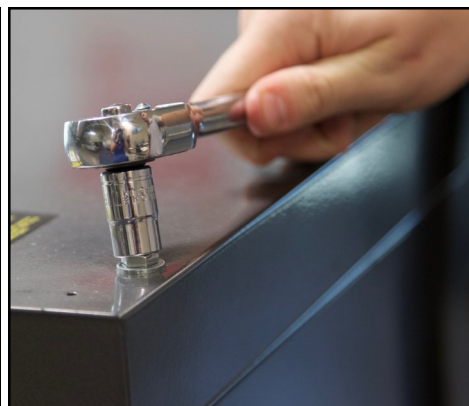

6. Tighten all eight bolts with a 7/16" socket wrench.

Step 8: Connecting to the engine.

1. Connect the wire of the belt motor to the wire of the engine.

Congratulations! The Powerhouse Quartz Dryer is now fully assembled!

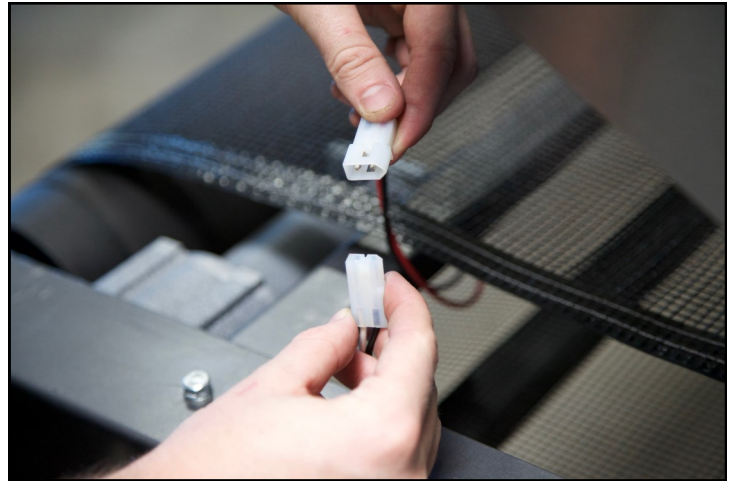

The size and specifications of the electrical connections made during installation **MUST BE DETERMINED BY A LICENSED ELECTRICIAN. FOLLOW ALL LOCAL BUILDING AND PLANNING CODES.** Failure to do so may result in damage to the unit, building, or cause serious injury.

Before any electrical connections are made verify all safety precautions have been taken to ensure the safety of all shop personnel. The dedicated breaker providing power to the dryer **MUST BE OFF, AND USE OF A SERVICE LOCKOUT TAG IS REQUIRED.** This will prevent anyone from turning on the power as the connections are being made. After all safety precautions have been taken the electrical connections can be made. All electrical connections must be made by a licensed electrician. Refer to factory specifications for proper installation.

Elements

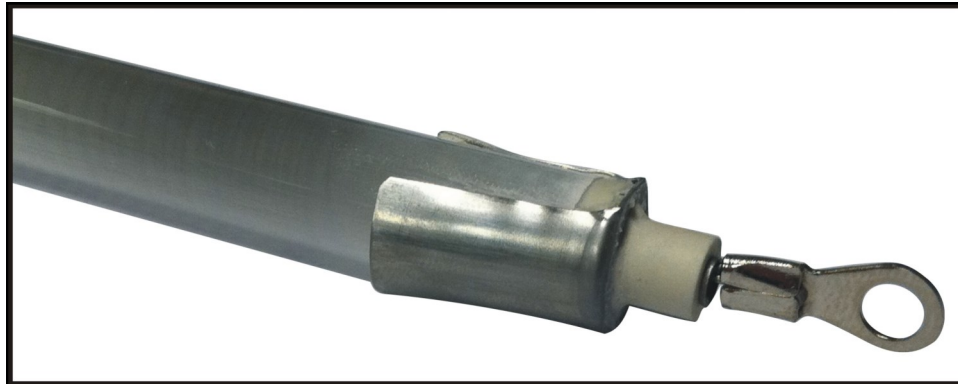

The quartz elements are installed using a ring terminal system. Fasten the elements securely to the buss bars using KEPS nuts as shown in Image 1.

Image 2 shows the opposite side of the elements, mounted in a similar manner.

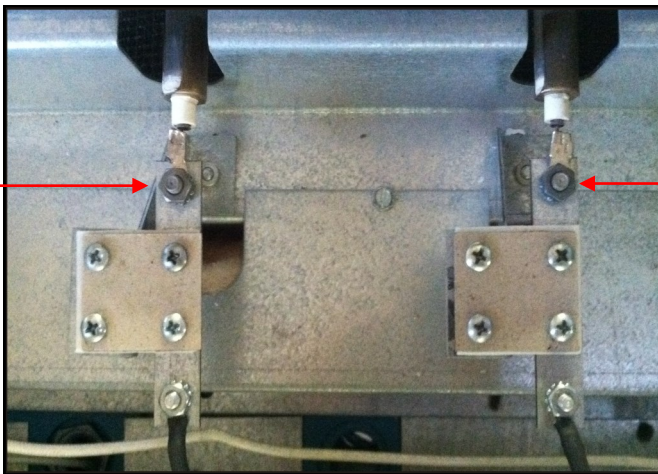

Image 1

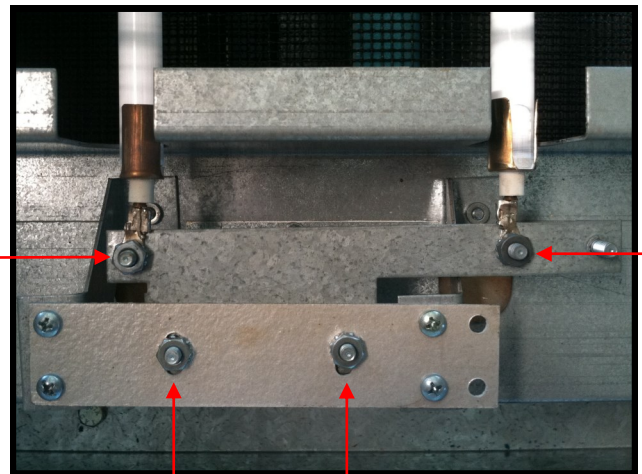

Image 2

When installing new elements it may be necessary to adjust the buss bar spacing. Loosen the 2 center nuts on the insulator plate in Image 2 to adjust the buss bar accordingly.

ALL HARDWARE MUST BE SECURELY FASTENED TO ENSURE PROPER CONTACT AND PREVENT DAMAGE TO THE ELEMENTS OR THE DRYER.

Dryer	Element Count	Voltage	Wattage each
PHQ-2608	6	230V	1400
PHQ-3011	12	230V	1000
PHQ-4013	12	230V	1000
PHQ-5208	6	230V	1700
PHQ-5217	16	230V	1700

Controls

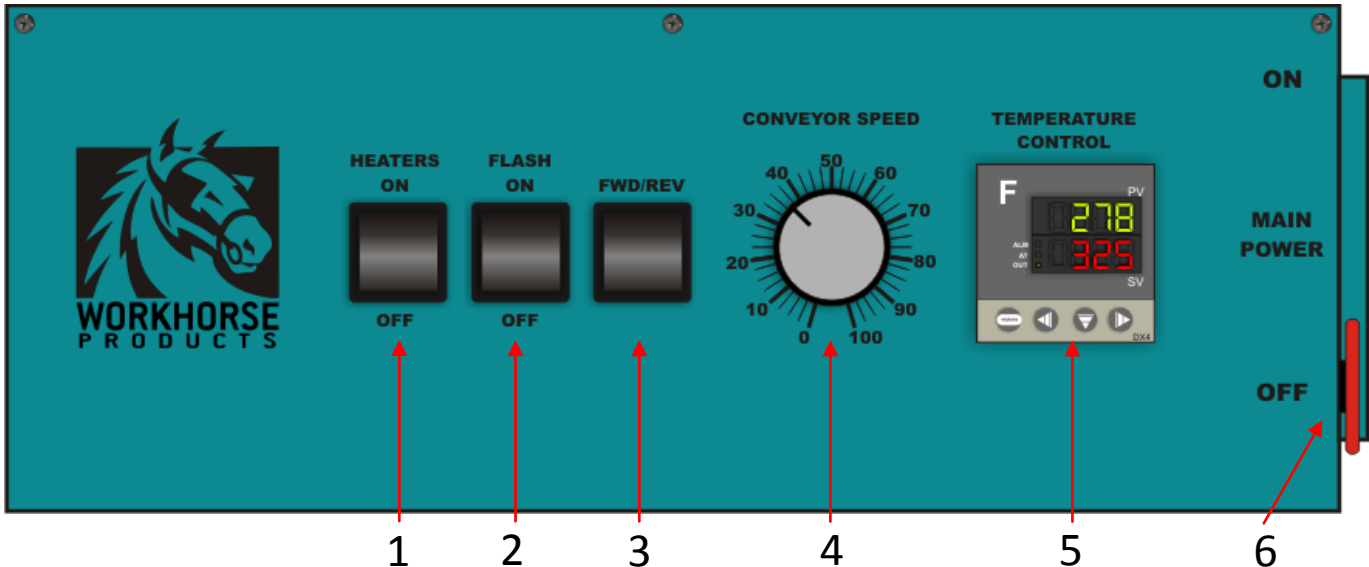

Before turning the dryer on make sure that the belt is empty and all of the switches on the front panel are in the off position.

1. Heaters: Turns on/off the quartz elements that are located inside of the dryer.
2. Flash: Turns on 2 to 4 (depending on the dryer model) elements for a quick burst of heat as the garments enter the dryer.
3. FWD/REV: Controls the direction of the belt. This may affect the belt tracking and additional adjustments may be needed to maintain proper belt tracking when changing the direction of belt travel.
4. Conveyor Speed: Controls the speed of the belt based on a percentage scale. For example, setting the knob at 40 means the belt is running at 40% of the maximum output voltage of 90 VDC. This is the factory recommended initial speed setting.
5. Temperature Control: The digital temperature control regulates the oven chamber temperature. The dual display shows both the current (red) and set temperature (green). When the dryer is coming up to temperature a small green indicator light labeled "OUT" will be illuminated. The factory recommended initial temperature setting is 310 degrees Fahrenheit. See page 28-29 for detailed functions.
6. Main Disconnect: Controls the main input power to the dryer. When the main disconnect for the dryer is turned on (red handle up) the belt, recirculation motor, cooling motor and temperature control may be operator.

When turning off the dryer, turn the "HEATERS" switch off first. Allowing the belt to run for 10 to 15 minutes with the elements off will allow the oven chamber to gradually cool down. Failure to follow this procedure may result in damage to the dryer and may pose a fire hazard.

Always check garment and ink manufacturers guidelines for proper garment curing and temperatures.

Please note that the actual temperature displayed by the controller is not the temperature of the garments in the oven chamber. The surface temperature of the garments may be significantly higher than the actual oven chamber temperature. Workhorse Products carries a non contact infrared digital thermometer to accurately measure the surface temperature of your garments. Please call customer service today for price and availability!

Recirculation System



All Powerhouse Quartz Dryers are equipped with an air recirculation system to convert radiant heat to convection heat. Convection heat is ideal for garment curing as it completely envelopes the garment and cures the ink more evenly.

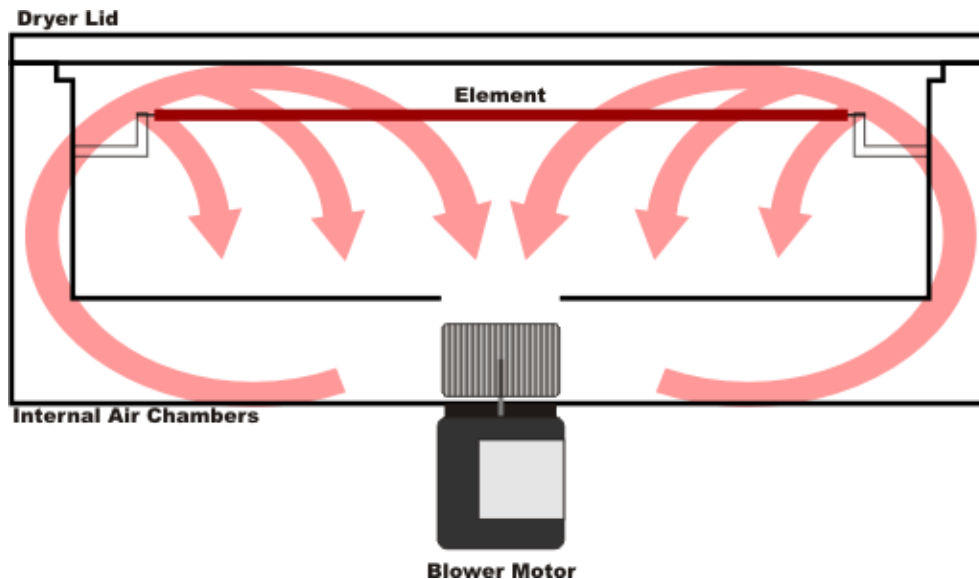

The diagram above shows the path of the circulating air. Drawn thru a center mounted blower motor the air is pushed through internal air chambers and down through the quartz element banks. The radiant heat from the elements is now transferred into the air converting it into convection heat.

General use of the dryer will cause lint and debris from garments and the surrounding atmosphere to collect inside the internal air chambers. Locate the blower motor mounted externally on the bottom of the heat chamber. Remove the two screws securing the motor mount. The motor assembly will swing out of the way allowing the removal of any lint or debris from the blower wheel and internal air chambers.

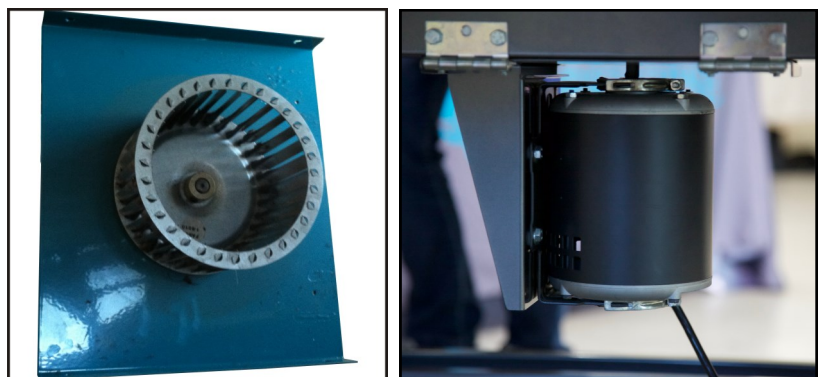

Workhorse Products recommends performing this routine maintenance every three to six months to maintain optimum performance of your dryer.

Ventilation



A ventilation hood has been installed on the factory out-feed side of the dryer. This can be connected to a standard duct line vented to the outside of the building. For longer duct lines to the outside of the building or if local building codes require roof top ventilation, inline duct boosters may be used.



An additional hood may also be installed on the infeed side of the dryer. It is recommended that the ventilation system is professionally installed in compliance to all local building codes to ensure the safety of all shop personnel.

Please call Workhorse Products Customer Service today for price and availability!

Temp. Control Programming



MYPIN TEMPERATURE CONTROLLER WIRING AND SETTING CONVEYOR DRYERS

FUNCTION

	Press the Set button to display the % of power being used to control the output device. Press again to return to the Set Value reading.
PV =	(Large Digit at Top) Temperature reading of thermocouple
SV =	Desired Temperature – Set Value
	To change the SV setting, press and release the AT button and the far right digit will flash. You can select another digit by pressing the AT button again.
	To change the value of the flashing digit press the UP or Down button. Typical setting is 350°
	Press the Set button to save the new value.
	Press and hold the Set button to exit the setting mode.



WIRING

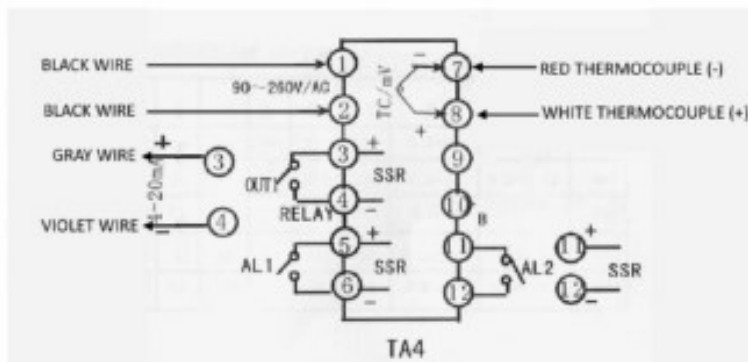

SETTINGS

There are two Parameter modes that you can access. The first has six values that can be modified. All of these values except one the controller program changes during operation, so normally you will not change these. The one value you can modify is the decimal point.

	Press and hold the Up and down buttons until "LSP" is displayed.
	Press the Set button 4 times until "dP" is displayed. 0 = No decimal point, 1 = One decimal point.
	Press the AT button to select the digit.
	Press the Up or Down button to change the value.
	Press the Set button to save the new value.
	Press and hold the Set button to exit the setting mode.







F-76002-2 REV. C

Temp. Control Programming



MYPIN TEMPERATURE CONTROLLER WIRING AND SETTING CONVEYOR DRYERS

The second parameter mode allows you to adjust the operating values of the controller. Note these values are the default values and some will change once you install the dryer. Follow the Auto-tuning instructions.

	Press and hold the Set buttons until "AL1" is displayed.
	Press the Set button to advance to the next setting.
	To change the current setting value, press and release the AT button and the far right digit will flash. You can select another digit by pressing the AT button again.
	To change the value of the flashing digit press the UP or Down button.
	Press the Set button to save the new value.
	Press and hold the Set button to exit the setting mode.

AL1	Alarm 1 set range – 0000-9999 Controller shuts down if over this Temp. 450	oUd	Control direction HEAT
A_1	Alarm 1 mode: 2 = Absolute value HI alarm	HYS	Control Hysteresis - not used 00
AL2	Alarm 2 set range – 0000-9999 OUT2/AL2 LED is on until temp is above low limit 80	CtL	Output Cycle Time - This is time in seconds the controller will cycle the output device to the heaters. (Solid State Relay). 05
A_2	Alarm 2 mode: 3 = Absolute value LOW alarm	trL	Low Analog Output – not used 0.00
PVF	Display Offset value. Displayed value = measured value – PVF If another device is used to measure the temp in the oven this value is the offset the display shows. = ±100 00	trH	High analog Output – not used 0.0
InP	Thermocouple type J	bSL	Temperature control method Pid
P	Proportional Band – 0.1-3600 or off 0.20	C - f	Temperature Unit F
I	Integral time range – 0.1-3600 or off 160.0	LCK	Parameter Lock Code 000 = Unlock, 010 = Locked
d	Derivative time range – 0.1-3600 or off 40		

AUTO-TUNING

It is best to Auto-Tune from a cold start.

	Press and HOLD the AT button until the AT LED turns on. The controller program will monitor and adjust the PID settings. The LED will remain ON until the process is finished then the LED will turn OFF.
---	--

F-76002-2 REV. C

Wiring Diagram

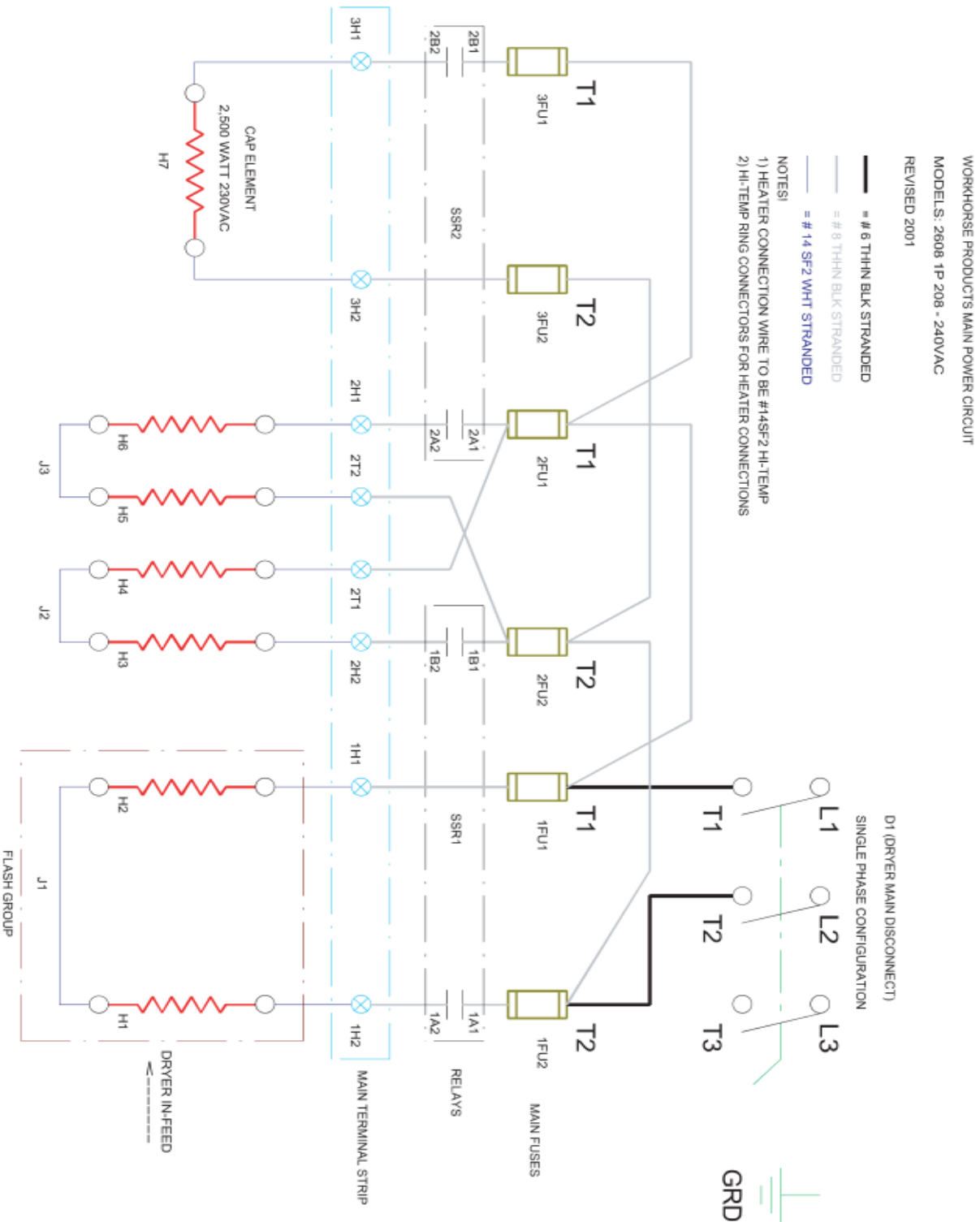

Wiring Diagram

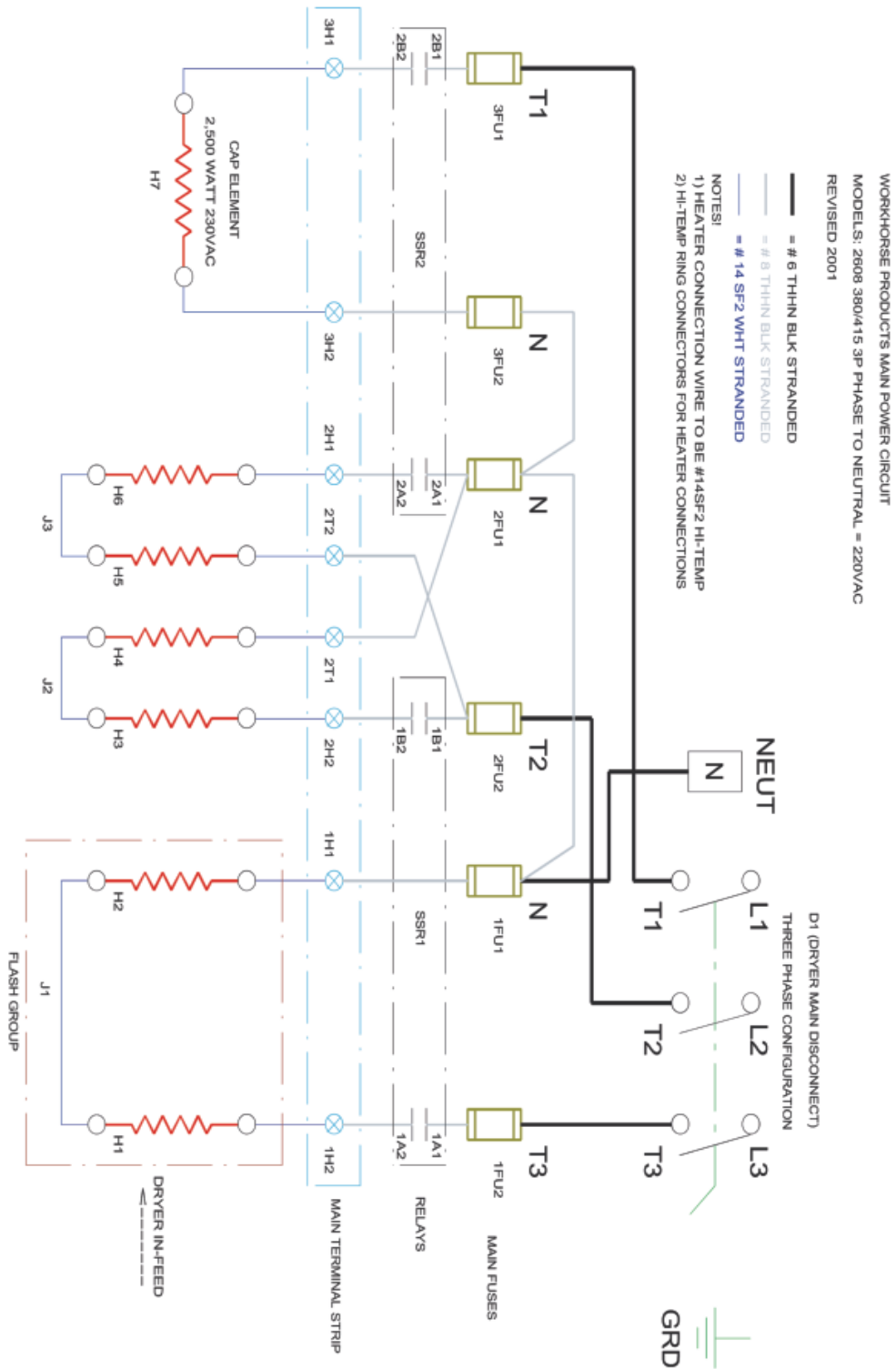

Wiring Diagram



WORKHORSE PRODUCTS CONTROL CIRCUIT
 MODELS: 2808 380/415VAC PHASE TO NEUTRAL = 220VAC
 REVISED 2009

D1 (ORDER MAIN DISCONNECT)
 SINGLE PHASE CONFIGURATION
 WARNING: DO NOT USE HIGH LEG

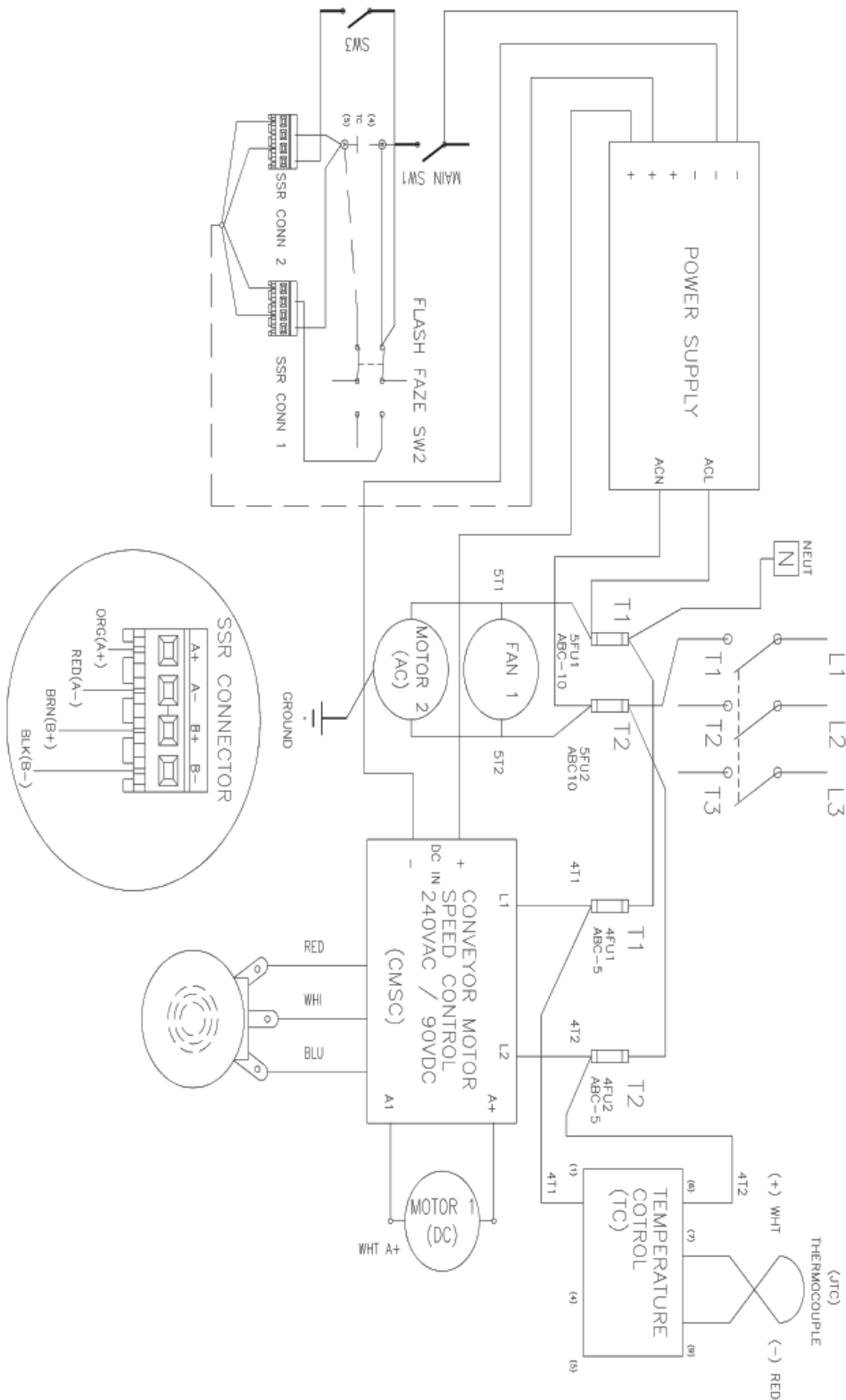

Wiring Diagram

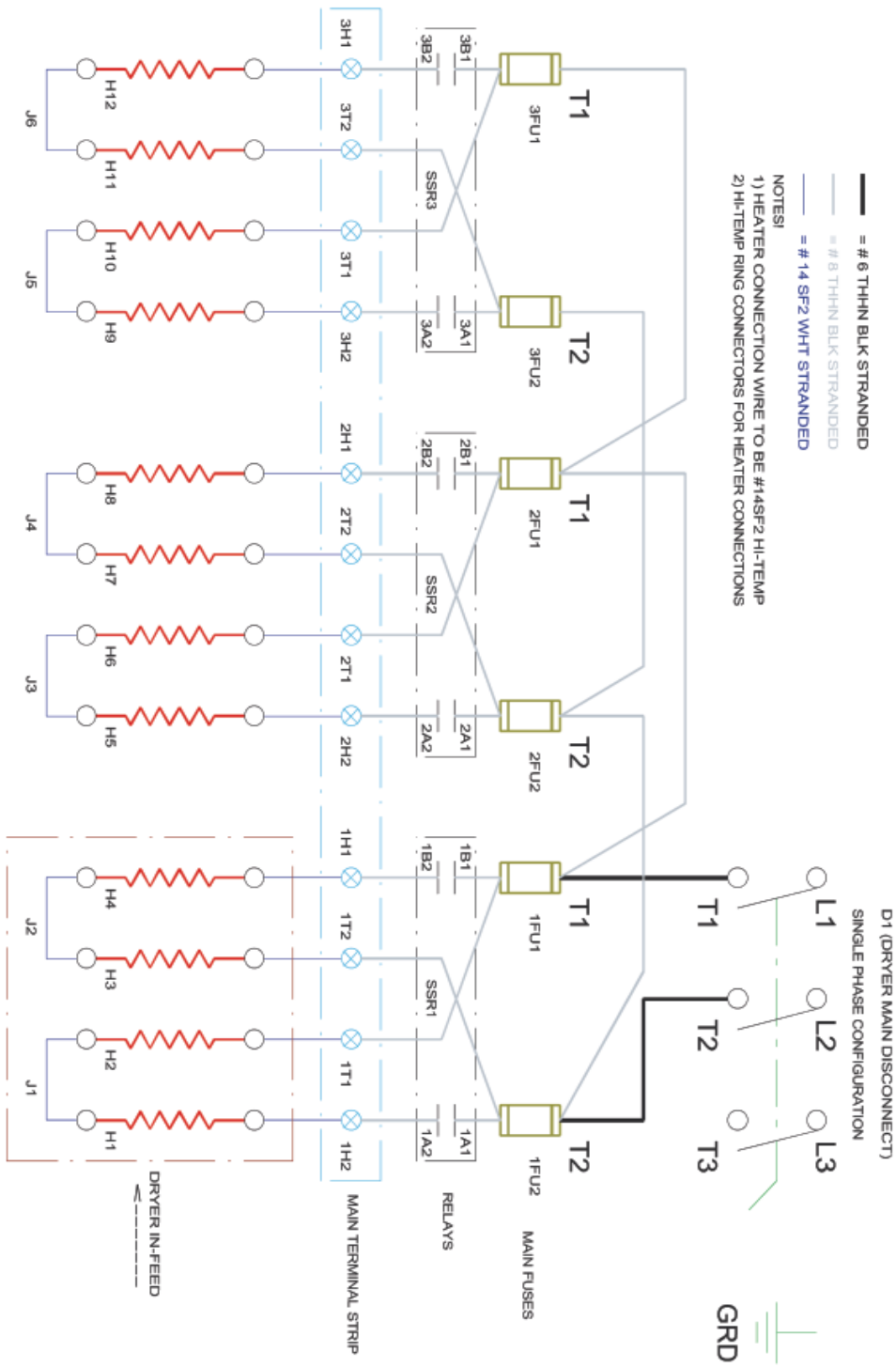

Wiring Diagram

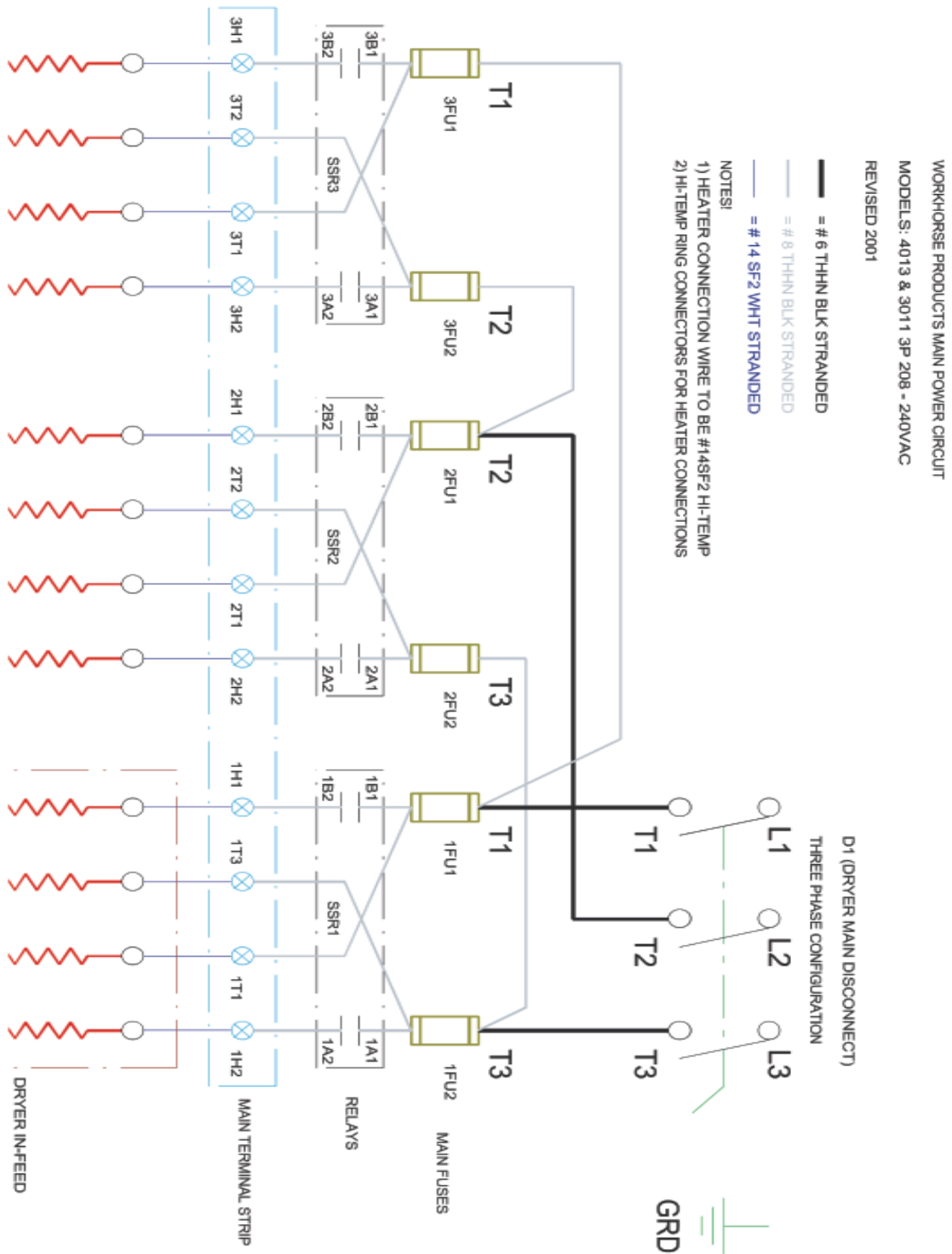

Wiring Diagram

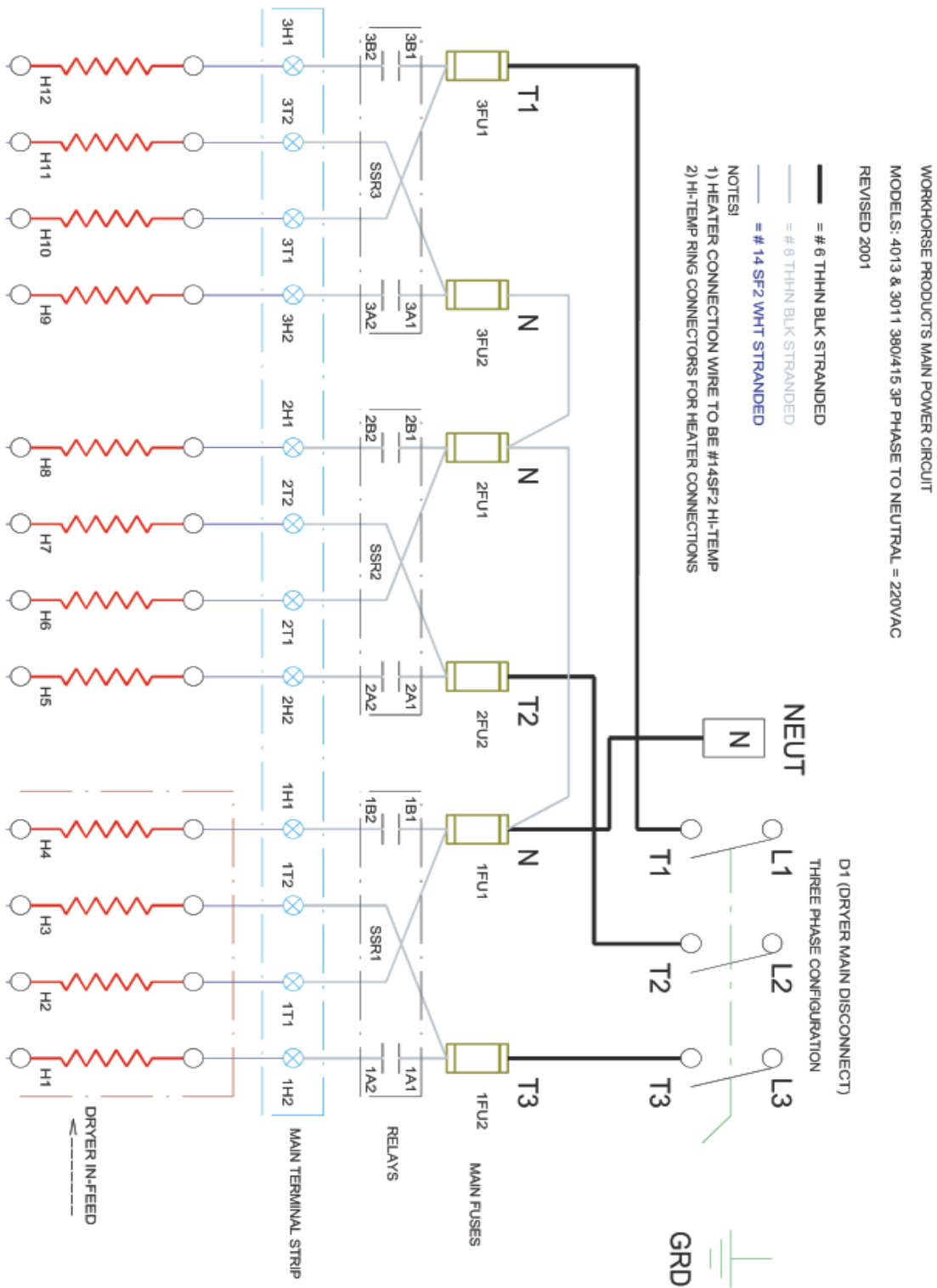

Wiring Diagram



WORKHORSE PRODUCTS CONTROL
 CIRCUIT
 MODELS: 4013 & 3011 208-240VAC
 REVISED 2009

D1(DRYER MAIN DISCONNECT)
 SINGLE PHASE CONFIGURATION
 WARNING: DO NOT USE HIGH LEG

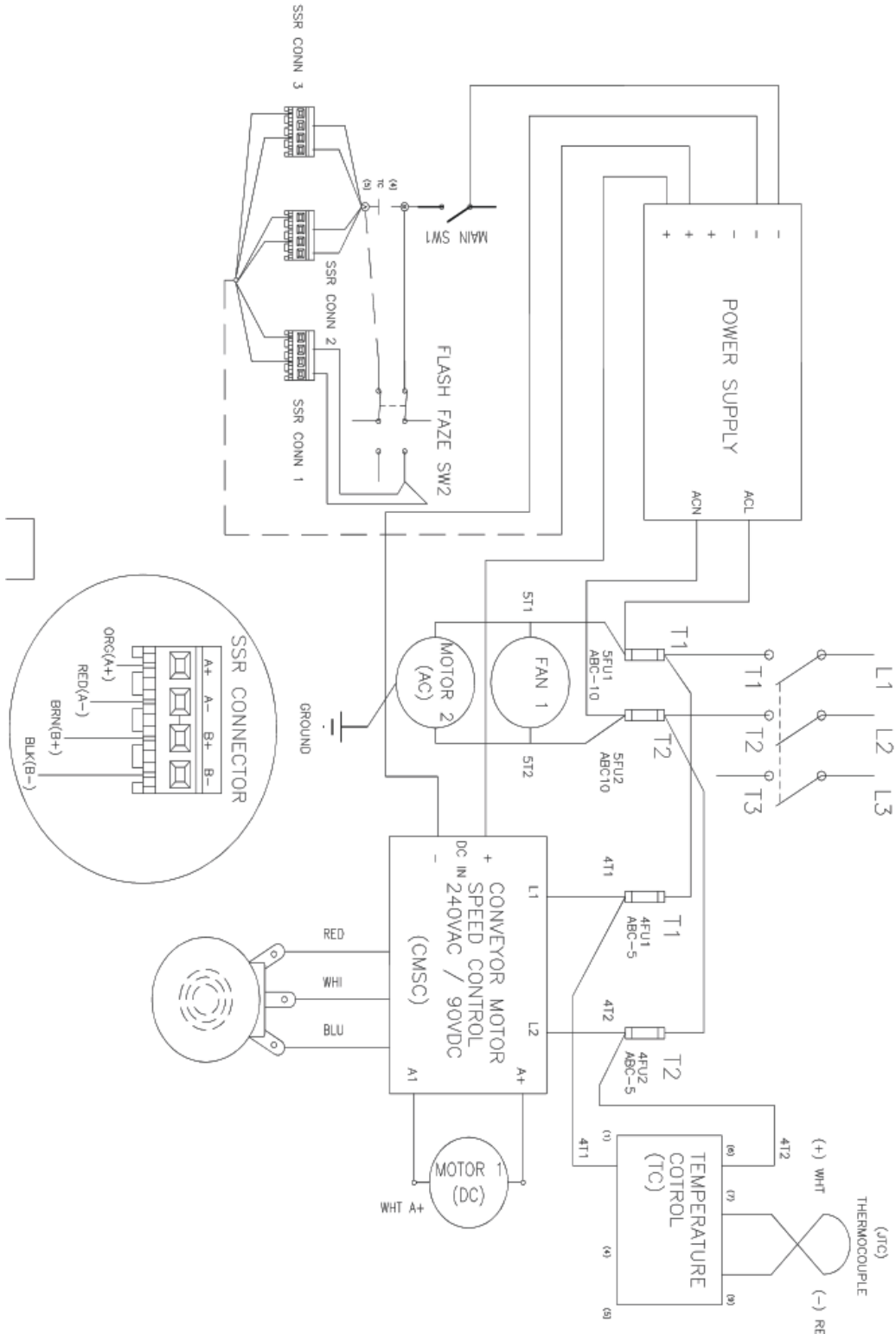

Wiring Diagram

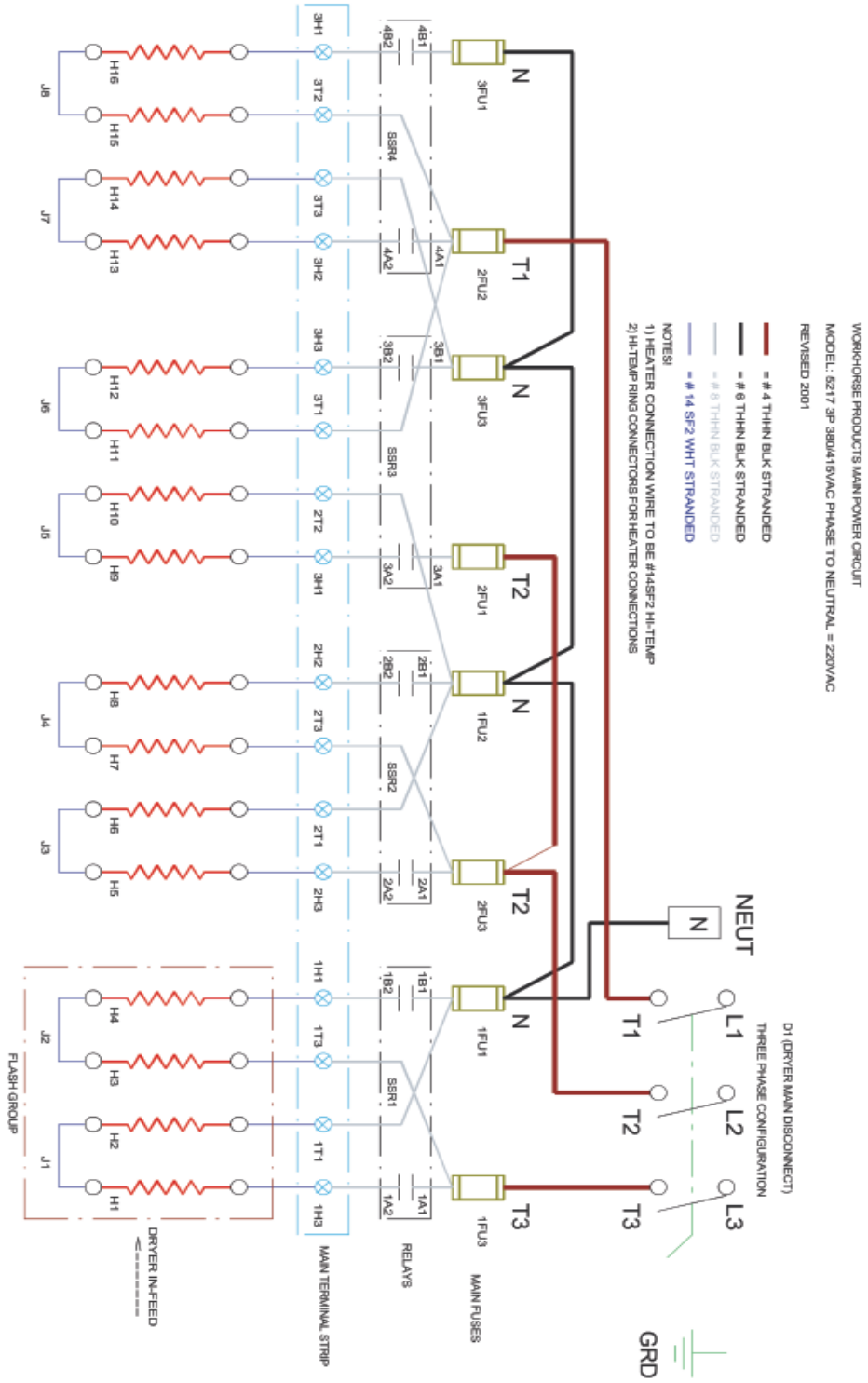

Wiring Diagram

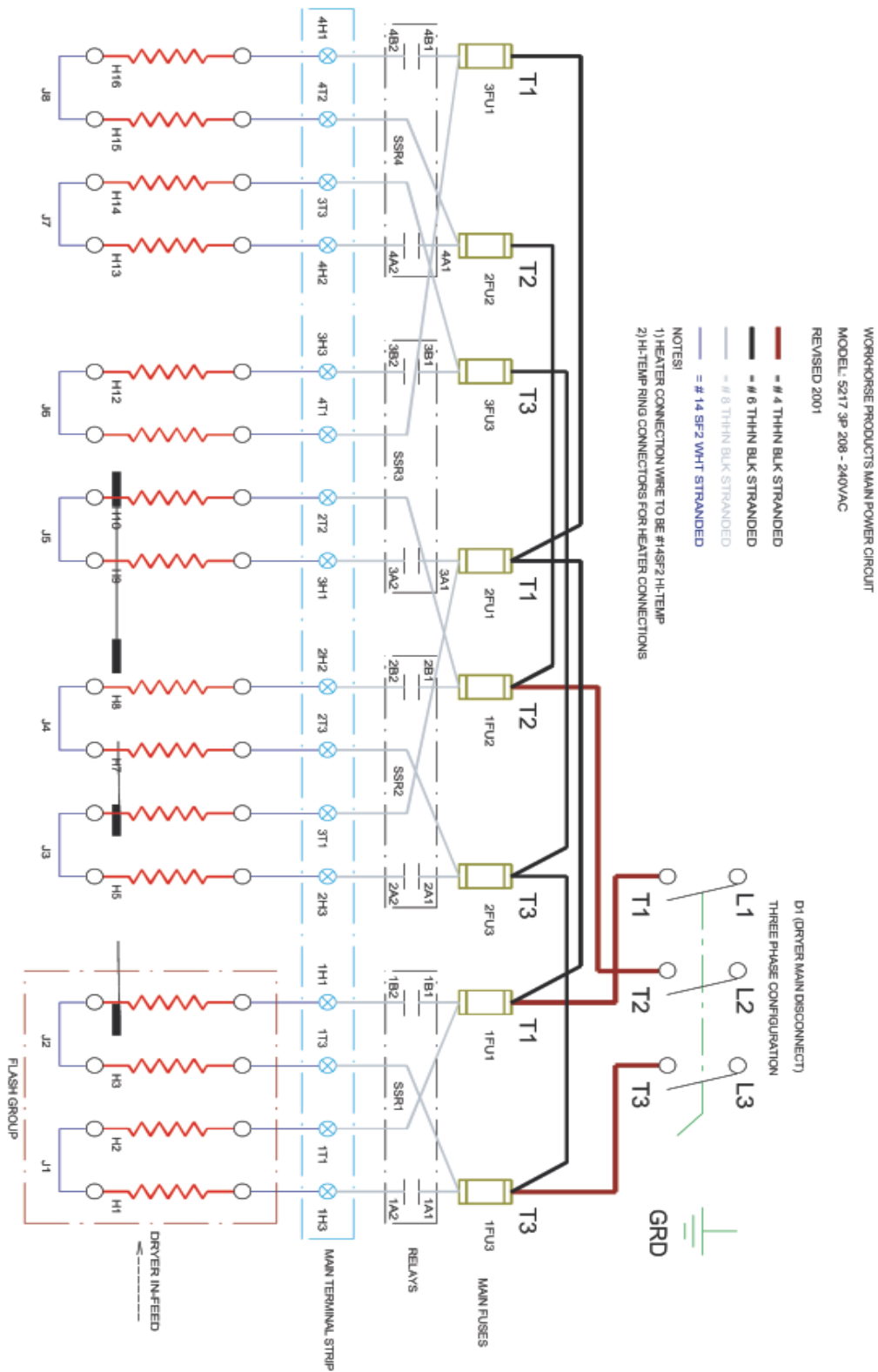

Wiring Diagram



WORKHORSE PRODUCTS CONTROL CIRCUIT
 MODELS: 5217 208-240VAC
 REVISED 2009

DI(ORDER MAIN DISCONNECT)
 SINGLE PHASE CONFIGURATION
 WARNING! DO NOT USE HIGH LEG

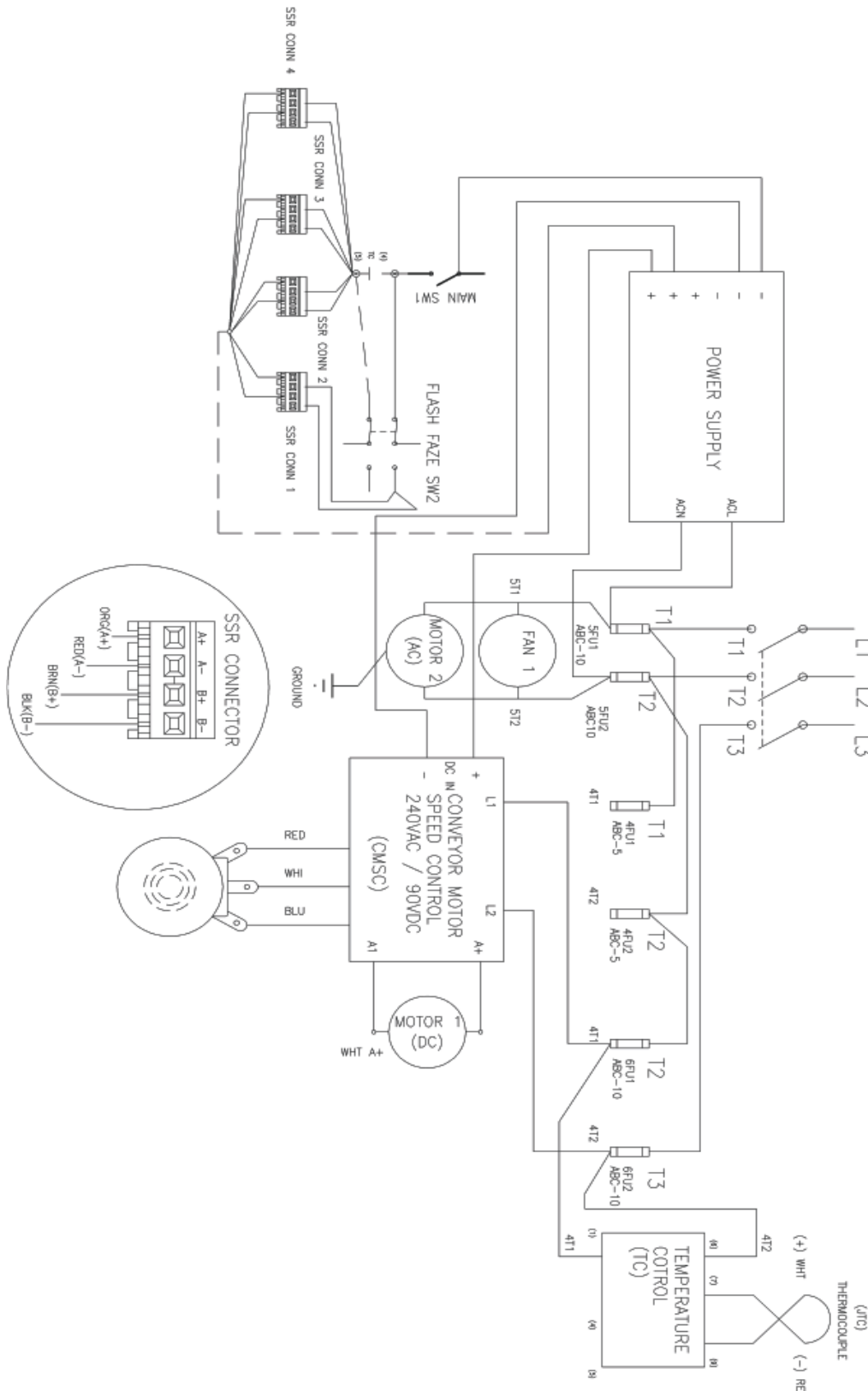

Wiring Diagram



WORKHORSE PRODUCTS CONTROL CIRCUIT
 MODELS: 5217 380/415VAC PHASE TO NEUTRAL = 220VAC
 REVISED 2009

D1(DRIVER MAIN DISCONNECT)
 SINGLE PHASE CONFIGURATION
 WARNING: DO NOT USE HIGH LEG

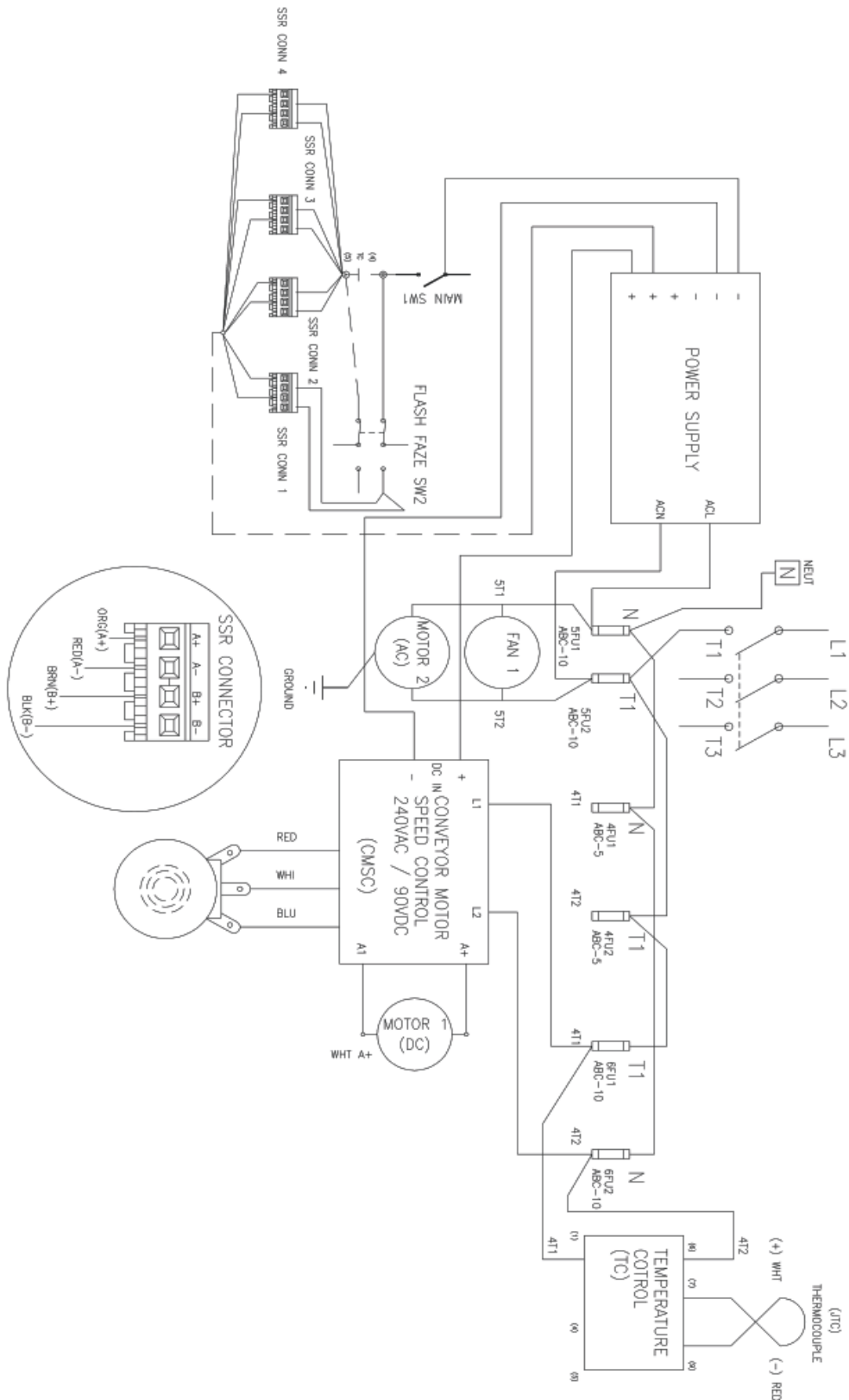

Limited Warranty



Although every effort has been made to provide accurate specifications, Workhorse Products does not assume any liability for damages, whether consequential or incidental, that may result from the use or misuse of the indicated specifications. Workhorse Products requires the use of a licensed industrial electrician for the installation of electrical service to equipment requiring electrical power.

Workhorse Products reserves the right to alter specifications in the manufacture of its products. It is understood and agreed that Seller's liability for any equipment whether liability in contract, in tort, under any warranty, in negligence, in strict liability or otherwise shall not exceed the return of the amount of the purchase price paid by Buyer. Notwithstanding the foregoing provision, under no circumstances shall Seller be liable for special, indirect or consequential damages. The price stated for the equipment is a consideration in limiting Seller's liability. No action regardless of form, arising out of the transactions under this Agreement may be brought by Buyer more than one (1) year after the cause of action has occurred. Our warranty is specified is exclusive and no other warranty, whether written or oral, is expressed or implied. Workhorse Products specifically disclaims the implied warranties of merchantability and fitness for a particular purpose. Equipment manufactured or sold by Workhorse Products is warranted against defects in workmanship and materials for a period of one year from receipt by customer. All warranties initiate from date of shipment to original customer. Replacement parts are covered for the term of the equipment warranty period. Parts not under warranty are covered for thirty (30) days from receipt by customer. Any part found by Workhorse Products to be defective in material or workmanship within the stated warranty period will be replaced or repaired at Workhorse's option without charge.

AFTER OBTAINING AN RMA# SEND RETURNED FREIGHT PREPAID TO 3730 E. Southern Avenue, PHOENIX, AZ 85040 USA.

Written authorization must be obtained from Workhorse before any part will be accepted. Replacement parts are sent out freight collect.

Parts sent out prior to receiving defective require a credit card hold for cost plus freight. Upon return of defective part, if it is deemed that the part was not damaged by customer but failed, the cost of the replacement part will be refunded.

This warranty does not extend to expendable parts such as filters, fuses, elements and brushes. Workhorse does not warrant failure of parts or components resulting from misuse or lack of proper maintenance. Installation, inspection, and

Registration Form	
Company Name: _____	Contact Name: _____
Address: _____ _____	Phone Number: _____
City: _____	Fax Number: _____
State: _____	Email : _____
Country: _____	Cell Number: _____
Zip Code: _____	Serial Number: _____
Model Number: _____	Date Recivied: _____
Date Purchased _____	

Please Fax Registration Form for warranty to take place