



ODYSSEY SERIES OWNER'S MANUAL

WWW.WORKHORSEPRODUCTS.COM

PARTS & SUPPLIES ARE AVAILABLE ONLINE AT:
<https://support.workhorseproducts.com/store/>

CONGRATULATIONS!

You are now the proud owner of an ODYSSEY SERIES Manual Printing Press. We thank you for choosing Workhorse Products!

While our packaging has been designed to handle normal shipping conditions, we cannot foresee damages caused by the carrier and are not responsible for damages that occur during transportation.

Please check the contents of the packaging for damages immediately.

If shipping damage has occurred:

- 1) Contact the carrier to file a claim immediately
- AND ----
- 2) Contact Workhorse Products at 800.778.8779

TABLE OF CONTENTS

- I. INTRODUCTION & SAFETY INFORMATION 4
- II. SPECIFICATIONS..... 5
- III. PARTS FOR ASSEMBLY..... 6
- IV. ASSEMBLY
 - STEP 1: INSTALLING THE SPRINGS..... 7
 - STEP 2: INSTALLING THE PALLET ARMS..... 8
 - STEP 3: INSTALLING THE PALLETS..... 9
 - STEP 4: LEVELING THE PRESS..... 10
- V. DISASSEMBLING PRESS FOR SMALL ENTRYWAYS..... 11
- VI. PRINT HEAD AND MICRO ADJUSTMENTS..... 12-13
- VII. MAINTENANCE AND TROUBLESHOOTING..... 14
- VIII. LIMITED WARRANTY..... 15

INTRODUCTION & SAFETY INFORMATION

THE IMPORTANCE OF THE OWNER'S MANUAL

The purpose of the Owner's Manual is to familiarize you with the parts and operations of the Odyssey Series Model. There are step-by-step instructions to assemble the press as well as troubleshooting information. Also included are explanations of the product's key features and additional information that will help with the maintenance of your press.

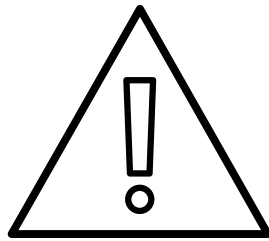

SAFETY

The Odyssey Series Manual Printing Press is intended to be used for manual screen printing of textiles. To avoid damage or injury, please be sure to use only for the purpose it was designed for.

- Anybody operating the press should first read through this owner's manual to ensure a full understanding of how to properly use and maintain the Mach.
- Do not sit, stand, or apply excess weight on press.
- Do not place foreign objects on press.
- Be sure print heads are in their upright position when installing and removing screens.
- Keep small children and pets out of reach of the press.
- Be sure the area around the press is free of clutter, spills, or debris.
- **IMPORTANT:** Shipping boxes and equipment are heavy. Use two persons for lifting!

SPECIFICATIONS

ODYSSEY 4/4

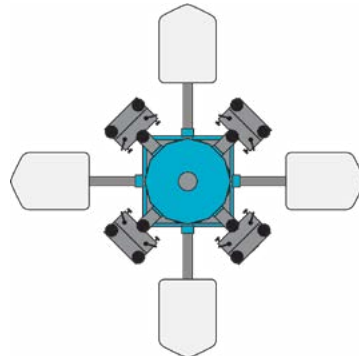

ODYSSEY 6/4

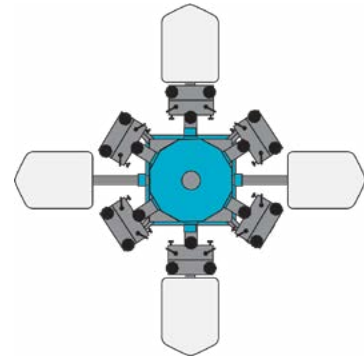

<i>Part Number</i>	O4400F	O6400F
<i>Colors/Stations</i>	4 Colors/4 Stations	6 Colors/4 Stations
<i>Max Screen Width</i>	44" (112cm)	25" (63.5cm)
<i>Dimensions (Diameter x Height)</i>	90" x 34-36" (229cm x 86-91cm)	90" x 34-36" (229cm x 86-91cm)

The Odyssey Series is shipped partially disassembled to prevent damage to the unit during transportation.

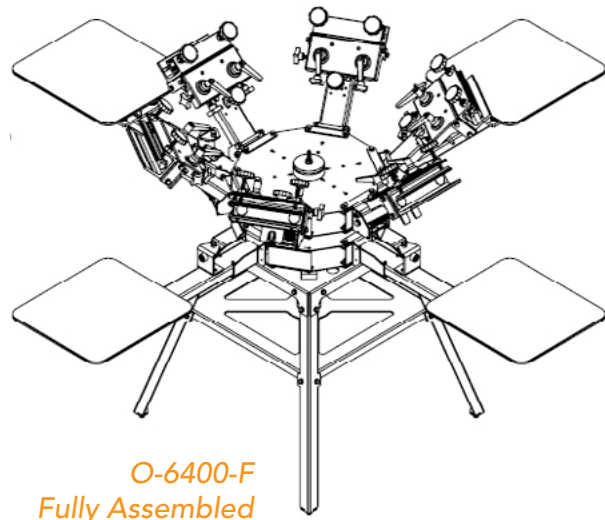
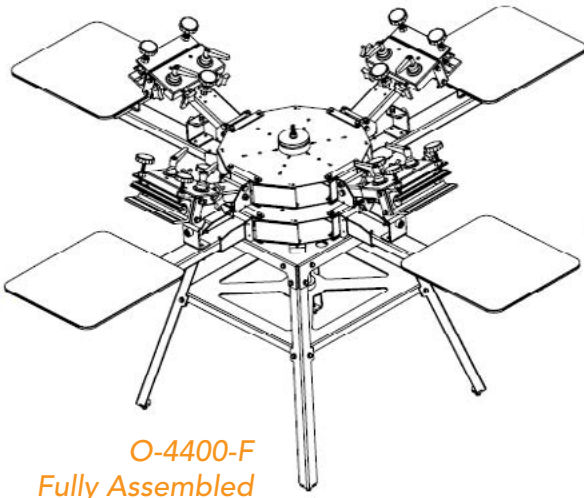

All parts are labeled on page 6 and will be referred to in the following steps. Any parts and tools that are necessary for assembly will be listed on each step. Please be sure you are using the correct tools and parts to assemble your press. Please check all parts before assembly.

IT IS RECOMMENDED THAT YOU ASSEMBLE YOUR PRESS WITH MORE THAN ONE PERSON

PARTS FOR ASSEMBLY

NOTE: Quantity of parts depends on model purchased. Reference the correct model in the table below for correct quantity of parts.

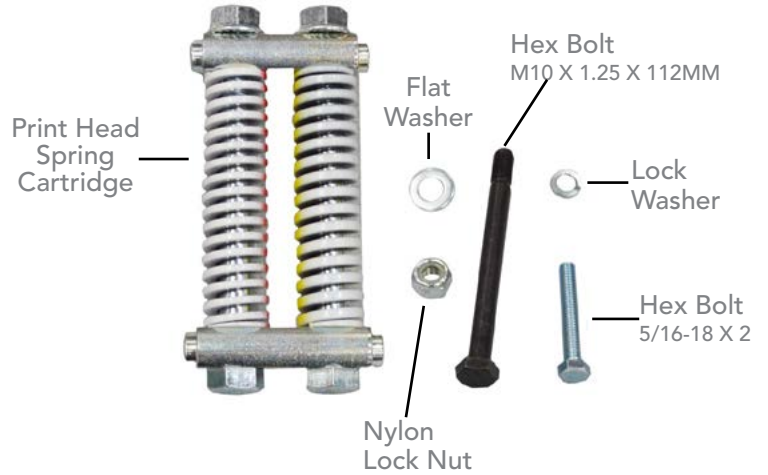

PART NO.	DESCRIPTION	QTY. 4/4	QTY. 6/4
PRE-ASSEMBLED	Base, Upper Turret, Lower Turret and Printheads	1	1
PRE-ASSEMBLED	Pallet Arm	4	4
21016	Spring Packs	4	6
41-HB-M10-60	Hex Bolt M10 X 1.25 X 112MM	4	6
42-NYL-M10-10	Nylon Lock Nut M10 x 1.25	4	6
43-FLT-M10-10	Flat Washer	8	12
41-HTB-3125-15	Hex Tap Bolt 5/16-18 X 2	16	16
43-LOK-3125-20	Lock Washer	16	16
75-20-1618	Pallet 16"x18"	4	4

ASSEMBLY

STEP 1: INSTALLING THE SPRINGS

TOOLS NEEDED

- 13mm wrench

PARTS NEEDED

- Spring packs
- Hex Bolts
- Flat Washers
- Nylon Lock Nuts

1. Lift up swing arm and locate empty grooves on the bottom of the swing arm. Place bottom of spring assembly into grooves as shown, then insert the top of the spring pack into the top grooves.
2. While spring pack is resting in place, lower swing arm onto top of spring assembly.
3. After installing spring assembly, push swing arm down and hold in place.
4. Install hex bolt with one washer from the side of swing arm.
5. Carefully release swing arm until it rests against the hex bolt.
6. Install nylon lock nut and washer on other side of bolt. Tighten with wrench.

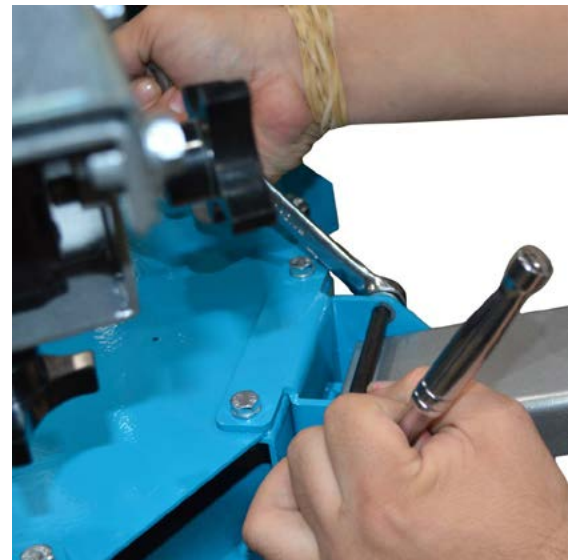
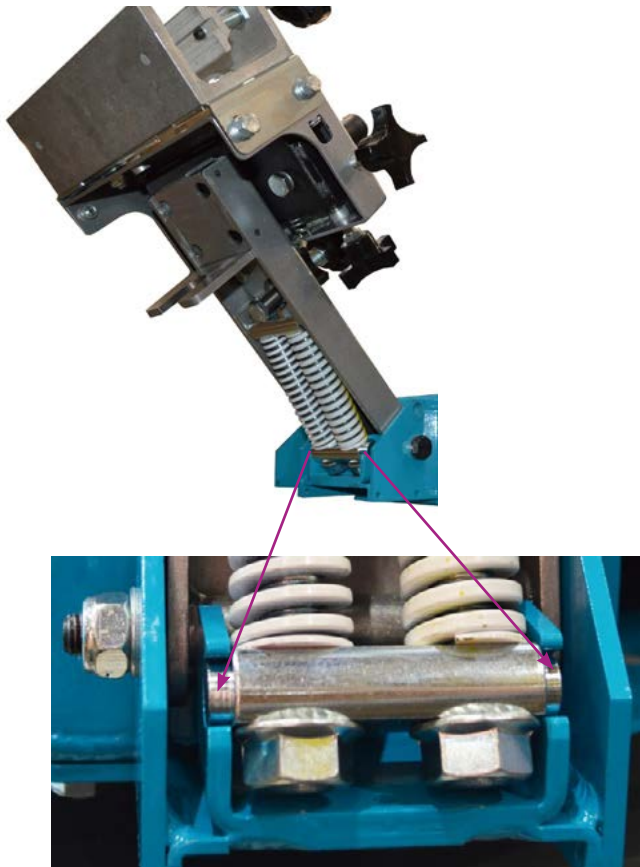

Repeat steps for each additional arm

ASSEMBLY

STEP 2: INSTALLING THE PALLET ARMS

TOOLS NEEDED

- 1/2" Wrench

PARTS NEEDED

- Pallet Arms
- Hex Tap Bolts
- Lock Washers

1. Match up number on pallet arm to number on lower wheel bracket. Place pallet arm into the lower wheel bracket. Line up pre-drilled holes on pallet arm to pre-drilled holes on the bottom of bracket.
2. Locate pre-drilled holes at the bottom of the bracket and use four hex tap bolts and four lock washers to secure one pallet arm into place. Tighten bolts using 1/2" wrench.



****Do NOT use hex nuts to hold in place or you could bend the pallet arm.****

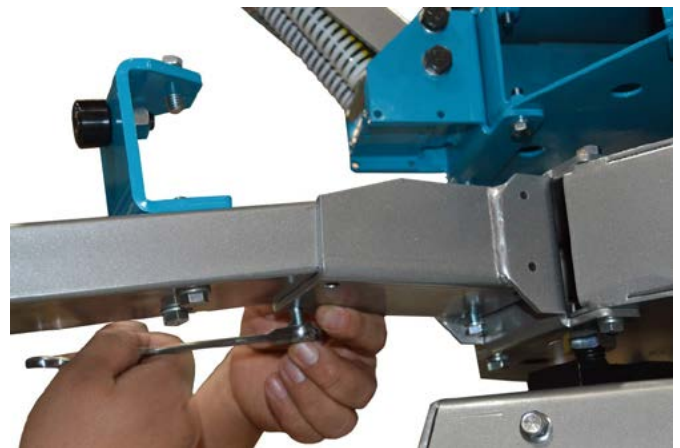

Repeat steps for each additional arm

ASSEMBLY

STEP 3: INSTALLING THE PALLETS

PARTS NEEDED

- Pallet Assembly
-

1. Be sure the hold down levers are all facing away from the press.
2. Take the pallet and begin sliding it onto the arm with the front side facing towards you. Make sure that the flange on bottom of the pallet fits under the hold down levers.
3. Pallet stopping point will vary by person depending on the size and placement of your artwork. Once you've determined your pallet location, lock in place by twisting the hold down levers to face the press.

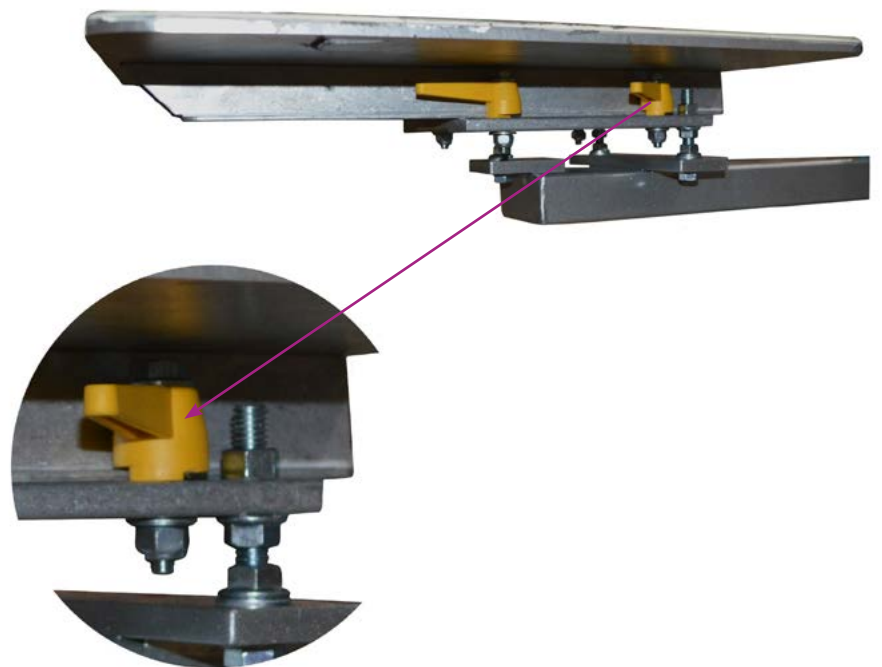

Repeat steps for each additional arm

ASSEMBLY

STEP 4: LEVELING THE PRESS

TOOLS NEEDED

- 9/16" Wrench
- Level

PARTS NEEDED

- Assembled Press

1. To start, place level on top center part of the pallet.
2. Using the level, start by rotating a pallet arm so it's above a base leg. You will use each leg position as a leveling point.



3. Using a 9/16 wrench, slowly twist leveling bolts on the bottom of the legs. Adjust until the level shows that leg is leveled.

Repeat step 3 at all 4 legs.

Keep the level placed on top of a pallet and rotate pallet through all stations, be sure that it remains level in each station.

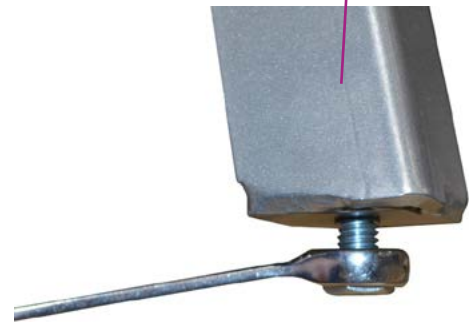

If you're having problems leveling your press, contact technical support at 800-778-8779 EXT 2.

DISASSEMBLING PRESS FOR SMALL ENTRYWAYS

(It is recommended to do this with more than one person)

TOOLS NEEDED

- 9/16" Wrench
- Level

PARTS NEEDED

- Assembled Press

In some circumstances, it may be necessary to disassemble the press to fit through a small entryway. If you are having difficulty moving your press through a small door or entryway, follow these instructions.

1. Take a wrench and remove the bolt that sits on top of the cap on the upper carousel wheel
2. Lift cap off to expose center shaft

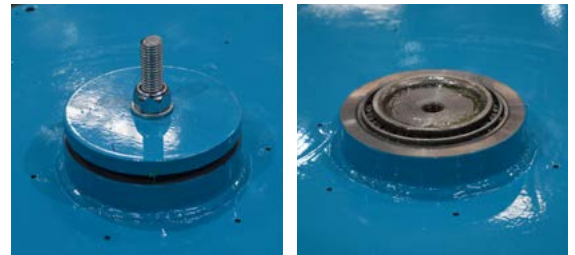

3. Lift the upper turret off of the center shaft and set aside
4. Remove the lower turret off the center shaft and set aside
5. Odyssey should now be in 3 smaller pieces allowing it to fit through a small doorway



6. Once through the door, put the lower turret and the upper turret back on the center shaft
7. Place the cap on top of the upper wheel and secure the bolt in place with a wrench



PRINT HEAD AND MICRO ADJUSTMENTS

- A** Side to Side Micro Adjustment
- B** Micro Lockdown Knobs
- C** Screen Lockdown Knobs
- D** Micro Adjusters
- E** Screen Tilt Adjustment
- F** Off Contact Knob

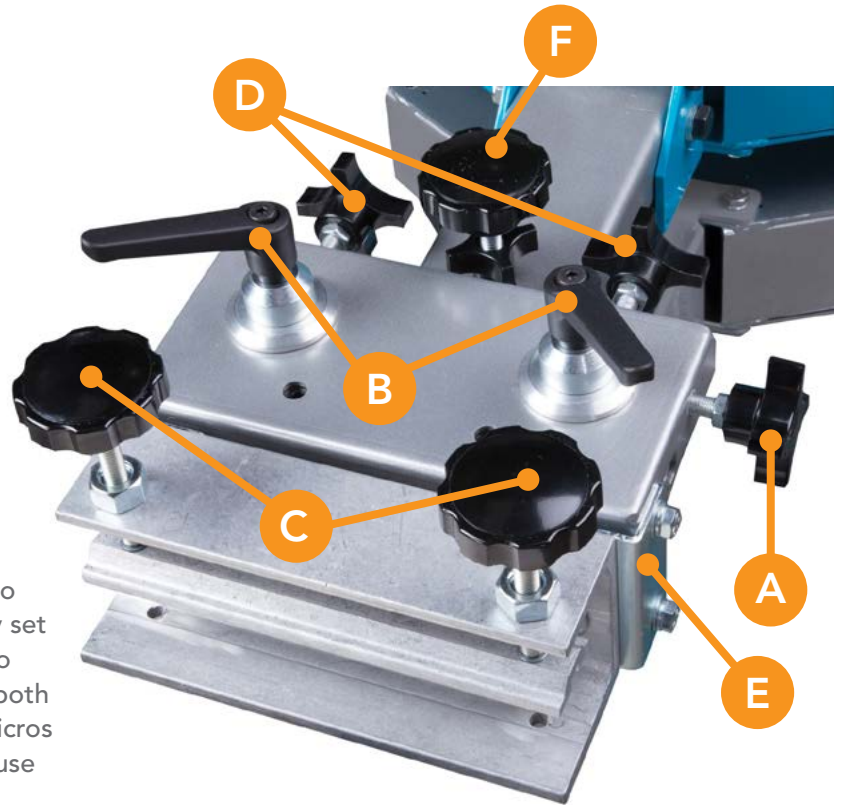

SIDE TO SIDE MICRO ADJUSTMENT (A)

Always loosen the micro lock down knobs (B) before beginning the adjustment. Turn the side-to-side micro adjuster to move the screen side to side, to properly set it must be used in conjunction with the X and Y micro adjusters (D). To utilize the full range of movement, both sets of adjusters must be used. Always center the micros either after completing a job or beginning one because it will save a lot of movement.

SCREEN LOCKDOWN KNOBS (C)

To place a screen in the print head, loosen the two screen lockdown knobs and raise the screen lockdown clamp bar until the screen can fit in. Then push the screen all of the way to the back of the screen clamp. After the screen is properly placed tighten the two screen lockdown knobs, but don't over tighten.

Tip: When using a back clamp printing press always measure the design height from the back of the screen, to confirm the design will register even when using different size screens.

MICRO ADJUSTERS (D)

Always loosen the micro lockdown knobs (B) before adjusting the micros. To adjust the registration, turn the X and Y micro adjusters (D). To move the screen left/right or up/down use the micro adjusters (D). To move the screen up/down without moving it to the left/right, turn both micro adjusters (D) at the same time. After adjustments are finished, tighten the micro lock down knobs (B), but don't over tighten.

SCREEN TILT ADJUSTMENT (E)

With the off contact strips on a pallet and a clean screen in the print head, lower the head to the pallet and inspect the tilt is touching both the front and rear strip.

If the front and rear off contact strips are not touching the screen ends equally, you will need to adjust the screen tilt.

To start, loosen the two screen tilt bolts (E) with a 1/2" wrench. Press the front of the screen until it makes contact with the plastic off contact strip. Next align the rear of the screen until it makes contact with the rear plastic off contact strip. After the off contact is consistent, tighten the two screen tilt bolts (E). Repeat as necessary on the other heads.

OFF CONTACT KNOB (F)

The Odyssey is set at a standard off contact, however there will be instances that require adjusting it. To readjust the off contact use knob (F) and use the 2 bolts (E) to adjust the tilt of the screen. When adjusting the tilt you will need to loosen the bolts, make the adjustments and then tighten back down.

Tip: This procedure will help set the off contact to be consistent and will require two 16" by 1" 10mm thick strips of plastic (screen door window plastic). Place one strip on the pallet at the front of the screen and one at the back of the screen. Adjust the screen until it makes contact with the plastic strips in the front and the back. This procedure is helpful because it shows if the front end of the screen is parallel with the back of the screen.

PRINT HEAD AND MICRO ADJUSTMENTS

Y AXIS MICRO
X AXIS MICRO

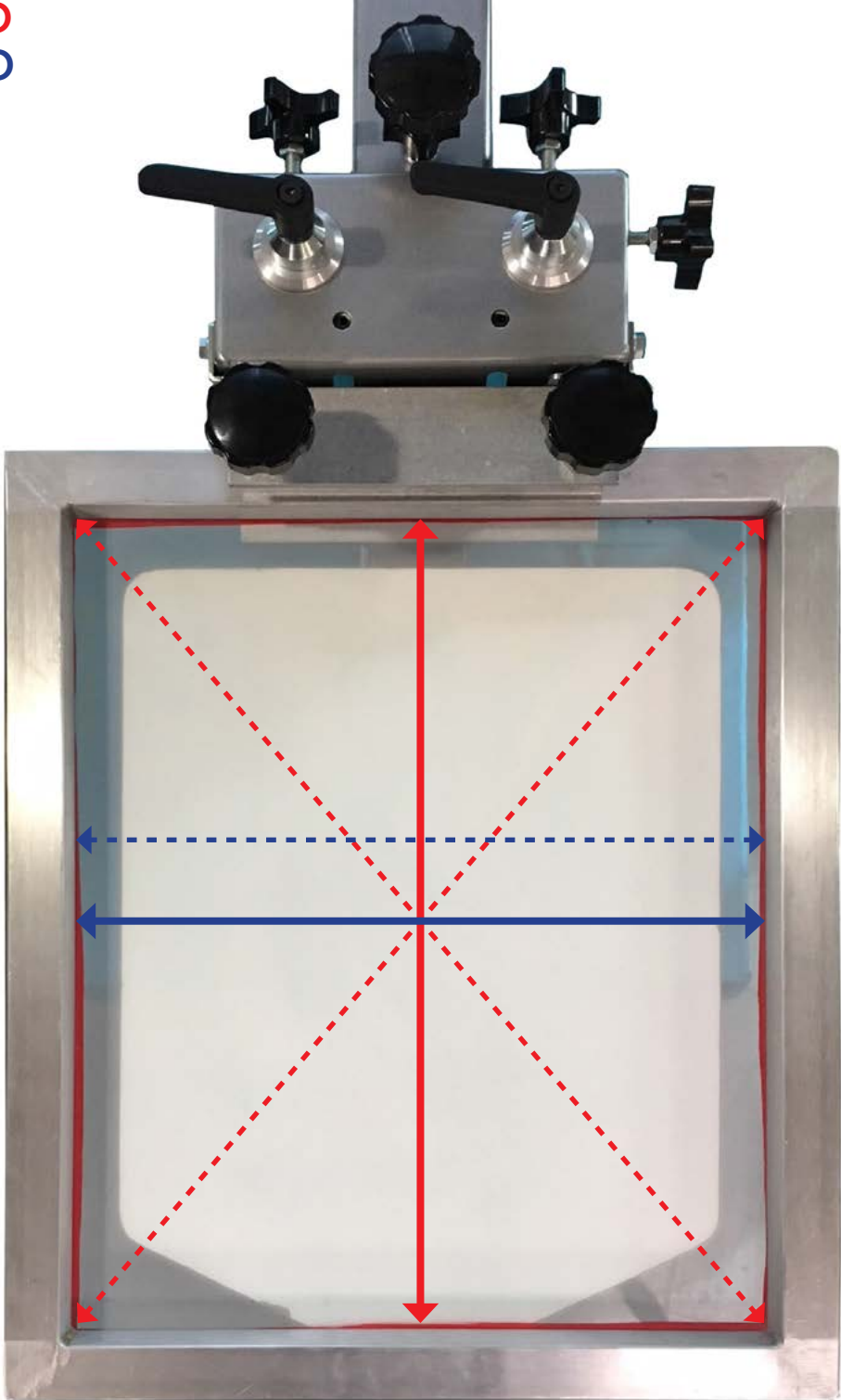

MAINTENANCE & TROUBLESHOOTING

The Odyssey Series does not require much maintenance, but periodic lubrication and cleaning will ensure smooth operation and extended life of the components. Do not let spray adhesive and lint accumulate. Wipe the press daily to remove spray adhesive and lint.

LUBRICATING THE MICROS

To lubricate, use spray lithium grease. Unscrew the (B) micro lock down knobs that attach the micro adjusters to the micro plate. Raise the head and spray the lithium in between the top of the head and the internal black cartridge. While doing so, work the micro knobs to work the grease and check for smooth movement of assembly.

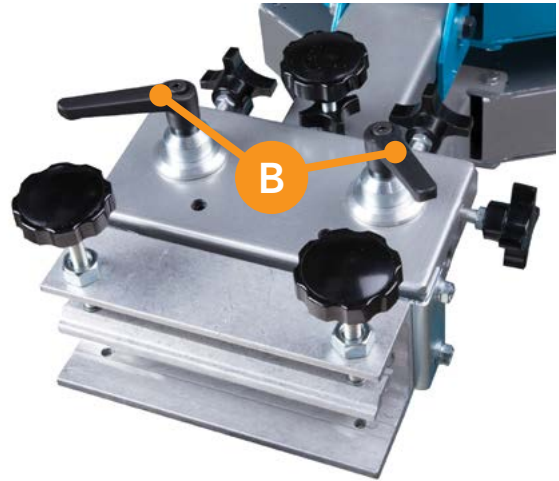

To lubricate the micros, back off the adjusters so most of the thread shows, apply a small dab of grease and work into the threads. Then screw down to reveal the other side and then repeat for the other side. After all of this, re-center the micros.

CLEANING

To clean the press, avoid using alcohol based solvents. Oil based paint thinner is better because it won't cut and dry out the grease.

TROUBLESHOOTING

If there are issues turning any of the knobs or micro adjusters, check to see that they are not gummed up with spray adhesive or ink. If the carousel becomes stiff or too easy to rotate, check to see that the top tension nut is not too tight or loose because it will determine if the tapered bearings need grease. Take off the jam nut to reach the resistant nut.

LUBRICATING THE CAROUSEL TAPERED BEARING

It is important to lubricate the top and bottom of the carousel tapered bearing at least twice a year. Lubrication may also be necessary if the rotation bearing becomes tight or uneven.

Use a wrench to remove the bolt from the Center Tapered Bearing.

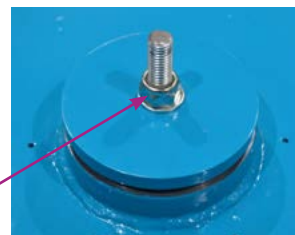

Lift the cap off to expose the center shaft.

Lift the upper carousel wheel off of the center shaft. Take a generous amount of grease and pack it onto the top and bottom of the center shaft. Remove the tapered bearing and work the grease onto the bearing separately. Be careful not to damage the race on the bearings.

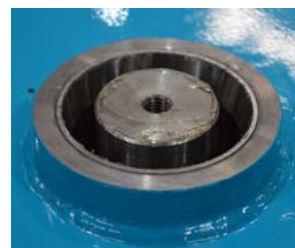

Once complete, return the bearings and the carousel wheel back into place. Put the cap back and tighten the bolt with a wrench.

LIMITED WARRANTY

Although every effort has been made to provide accurate specifications, Workhorse Products does not assume any liability for damages, whether consequential or incidental, that may result from the use or misuse of the indicated specifications. Workhorse Products requires the use of a licensed industrial electrician for the installation of electrical service to equipment requiring electrical power.

Workhorse Products reserves the right to alter specifications in the manufacture of its products. It is understood and agreed that Seller's liability for any equipment whether liability in contract, in tort, under any warranty, in negligence, in strict liability or otherwise shall not exceed the return of the amount of the purchase price paid by Buyer. Notwithstanding the foregoing provision, under no circumstances shall Seller be liable for special, indirect or consequential damages. The price stated for the equipment is a consideration in limiting Seller's liability. No action regardless of form, arising out of the transactions under this Agreement may be brought by Buyer more than two (2) years after the cause of action has occurred. Our warranty is specified, is exclusive and no other warranty, whether written or oral, is expressed or implied. Workhorse Products specifically disclaims the implied warranties of merchantability and fitness for a particular purpose. Equipment manufactured or sold by Workhorse Products is warranted against defects in workmanship and materials for a period of one year from receipt by customer. All warranties initiate from date of shipment to original customer. Replacement parts are covered for the term of the equipment warranty period. Parts not under warranty are covered for thirty (30) days from receipt by customer. Any part found by Workhorse Products to be defective in material or workmanship within the stated warranty period will be replaced or repaired at Workhorse's option without charge.

**AFTER OBTAINING AN RMA# SEND RETURNED FREIGHT PREPAID TO:
3730 E. Southern Avenue, PHOENIX, AZ 85040 USA.**

Written authorization must be obtained from Workhorse before any part will be accepted. Replacement parts are sent out freight collect. Parts sent out prior to receiving defective require a credit card hold for cost plus freight. Upon return of defective part, if it is deemed that the part was not damaged by customer but failed, the cost of the replacement part will be refunded.

This warranty does not extend to expendable parts such as filters, fuses, elements and brushes, springs, hog rings, nylon bolts, pallets and casters. Workhorse does not warrant failure of parts or components resulting from misuse or lack of proper maintenance. Installation, inspection, and maintenance costs are the sole responsibility of the purchaser.

FOR WARRANTY TO TAKE PLACE YOU MUST COMPLETE THE PRODUCT REGISTRATION FORM ONLINE:

<https://workhorseproducts.com/equipment-registration-form/>



WWW.WORKHORSEPRODUCTS.COM

PARTS & SUPPLIES ARE AVAILABLE ONLINE AT:
<https://support.workhorseproducts.com/store/>

67-1455 REV0322