

Owner's Manual

ODYSSEY BENCH MODEL



67-1375 REV 218

Table of Contents

I. Introduction & Safety Information.....	3
II. Specifications	4
III. Parts for Assembly.....	5
IV. Order of Assembly.....	6
V. Assembly	
Step 1: Installing the Pallet Arm.....	7
Step 2: Installing the Print Heads.....	8
Step 3: Installing the Springs.....	9
Step 4: Installing the Pallet.....	11
V. Print Head and Micro Adjustments.....	13
VI. Maintenance and Troubleshooting.....	16
VII. Limited Warranty.....	18

Introduction & Safety

Congratulations on your purchase of the Odyssey Manual Printing Press. We'd like to thank you for choosing Workhorse Products!

Check the crate for damages. DO NOT accept the crate if there are any damages caused by improper handling during shipping. Immediately report any damages to the carrier and contact Workhorse Products at, 800-778-8779.

Be sure to inspect the crate contents IMMEDIATELY, while the carrier is still present. Even though our packaging has been designed to handle normal shipping conditions, we cannot foresee damages done by the carrier. We will not be responsible for damages that occur during transportation.

If there are damages immediately notify the driver, file a claim with the carrier and call Workhorse Products.

The Importance of the Owner's Manual:

The purpose of the Owner's Manual is to familiarize you with the parts and operations of the Odyssey Bench Model. There are step-by-step instructions to assemble the press as well as troubleshooting information. Also included are explanations of the product's key features, and additional information that will help with the maintenance of your press.



Safety

The Odyssey Manual Printing Press is intended to be used for manual screen printing of textiles. To avoid damage or injury, please be sure to use only for the purpose it was designed for.

- **Anybody operating the press should first read through this owner's manual to ensure a full understanding of how to properly use and maintain the Odyssey.**
- **Do not sit, stand, or apply excess weight on press.**
- **Do not place foreign objects on press.**
- **Be sure print heads are in their upright position when installing and removing screens.**
- **Keep small children and pets out of reach of the press.**
- **Be sure the area around the press is free of clutter, spills, or debris.**

Specifications



O-1100-B

1 Color, 1 Station

Max Screen: N/A

Dimensions: 34" x 14" x 27"



O-2100-B

2 Color, 1 Station

Max Screen: N/A

Dimensions: 56" x 38" x 27"

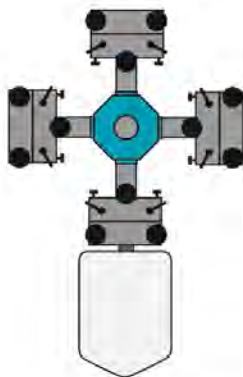

O-4100-B

4 Color, 1 Station

Max Screen: 32" (81 cm)

Dimensions: 56" x 38" x 27"

Parts for Assembly

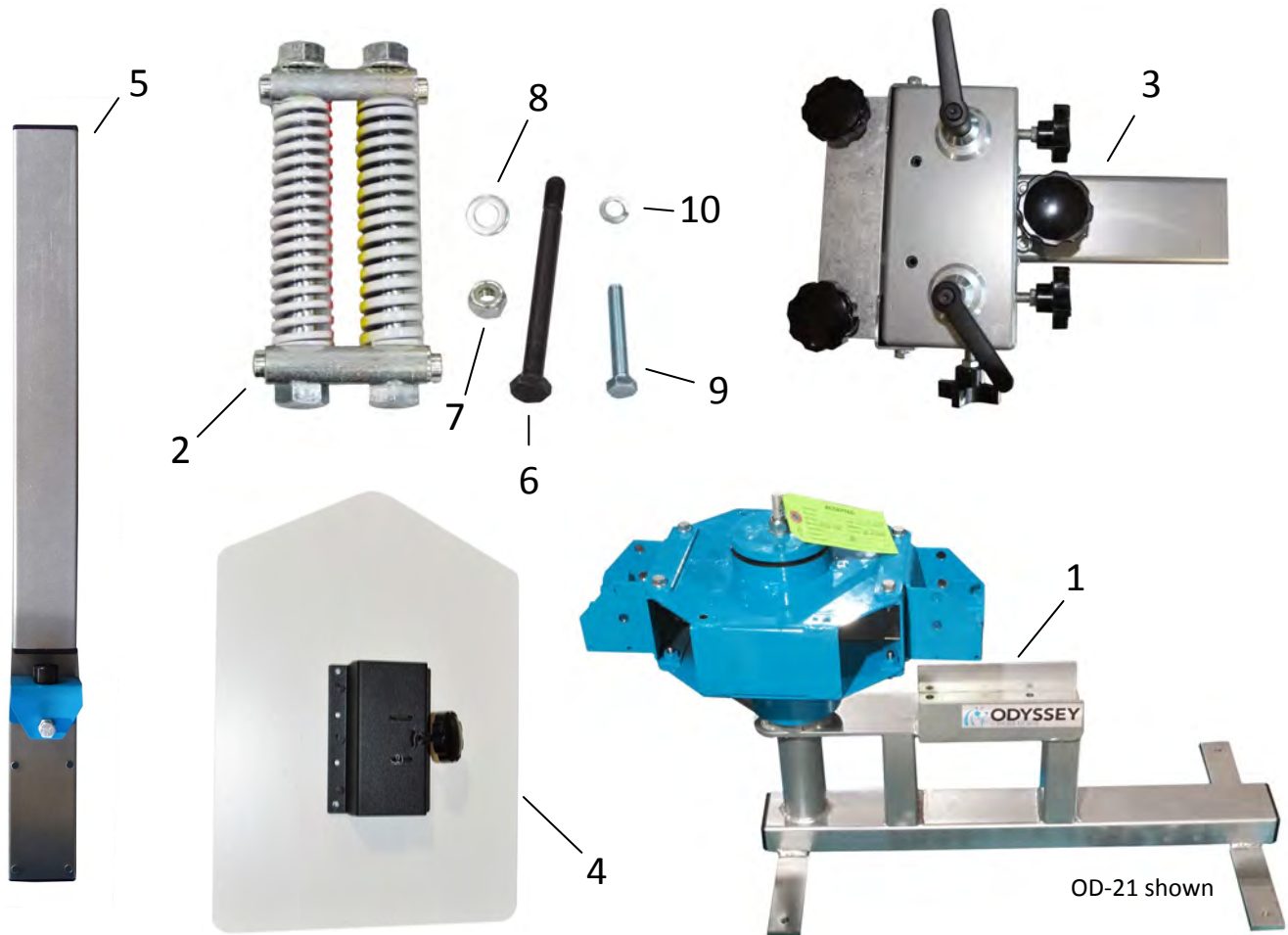

ITEM #	QTY OD-11	QTY OD-21	QTY OD-41	PART NUMBER	DESCRIPTION
1	1	1	1	Varies by model	MAIN ASSEMBLY (AS SHIPPED)
2	1	2	4	21016	SPRING PACKS
3	1	2	4	21011 or 21023	PRINT HEADS
4	1	1	1	75-20-1618	PALLETS 16 X 18
5	N/A	1	1	21017	PALLET ARM
6	2	4	8	41-HB-M10-10	HEX BOLTS
7	2	4	8	43-NYL-M10-10	NYLON LOCK NUTS
8	2	4	8	43-FIT-M10-10	FLAT WASHERS
9	N/A	4	4	41-HTB-3125-15	HEX TAP BOLTS
10	N/A	4	8	43-LOK-3125-20	LOCK WASHERS

*Quantity of parts depends on model purchased. Reference your Model Number in table above for correct quantity of parts.

Order of Assembly

The Odyssey is shipped partially disassembled to prevent damage to unit during transportation.



Order of Assembly:

1. Installing the Pallet Arm
2. Installing the Print Heads
3. Installing the Springs
4. Installing the Pallet

All parts are labeled on page 5 and will be referred to in the following steps. Any parts and tools that are necessary for assembly will be listed on each step. Please be sure you are using the correct tools and parts to assemble your press.

Assembly

Step 1: Installing the Pallet Arm

This will not apply to the O-1100-B

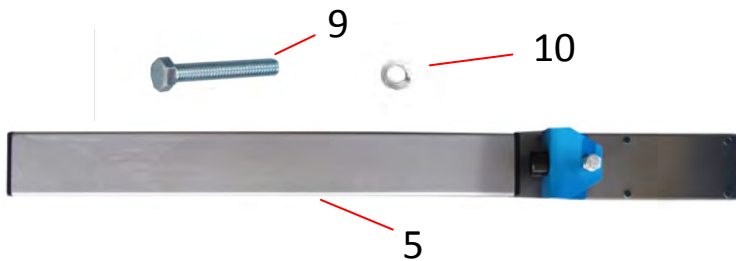

PARTS NEEDED	TOOLS NEEDED
PALLET ARM (Item # 5)	1/2" WRENCH
HEX TAP BOLTS (Item #9)	
LOCK WASHERS (Item #10)	

*quantity of parts depends on model being assembled

1. Gather the pallet arm, four hex bolts and four washers.
2. Take the pallet arm and locate the four pre-drilled holes. Insert the pallet arm into the bracket ensuring the pre-drilled holes on the pallet arm line up with the pre-drilled holes on the bracket.
3. It will be a very tight fit so you may need to push and pull the arm a bit until the holes meet each other.
4. Once lined up, take your hex bolt with a washer attached and push the bolt through one of the pre-drilled holes from the underside of the pallet arm. Use a wrench to twist the bolt into place.
5. Once it is all the way through, you will be able to see the tip of the bolts coming through each hole on the top of the pallet arm.

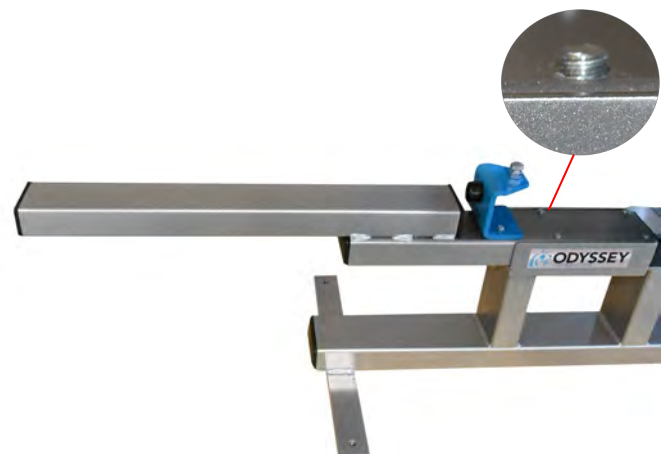
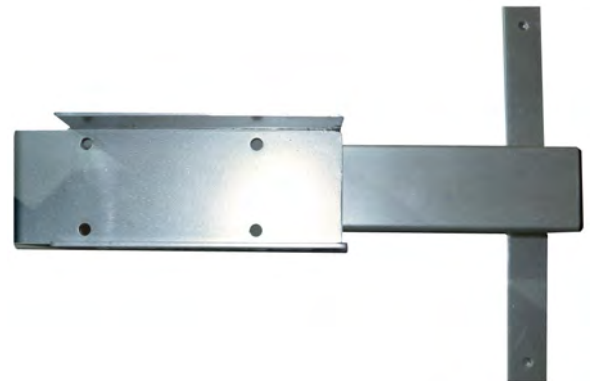

Assembly

Step 2: Installing the Print Heads

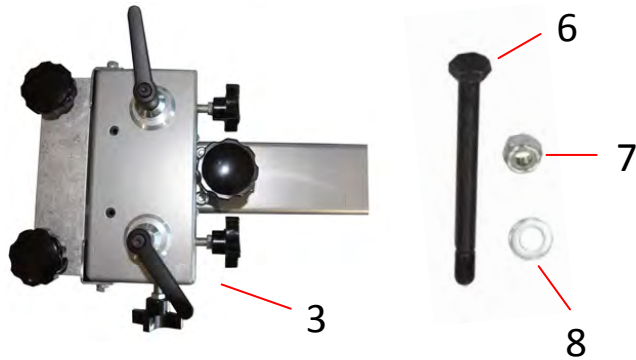

PARTS NEEDED

PRINT HEADS (Item #3)

HEX BOLTS (Item #6)

FLAT WASHERS (item #8)

LOCK NUTS (Item #7)

*quantity of parts depends on model being assembled

TOOLS NEEDED

11/16" WRENCH

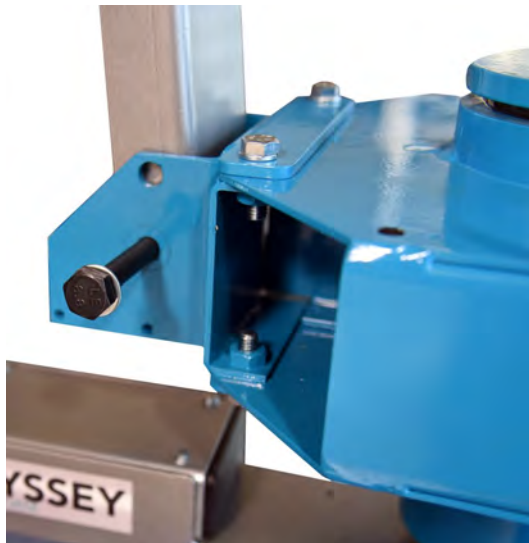

1. Gather one hex bolts, one lock nut and two washers for each print head being installed.

2. Take the print head and place the arm into the bracket so that it is standing upright. Line up the pre-drilled hole on the swing arm with the lower pre-drilled hole on the bracket.

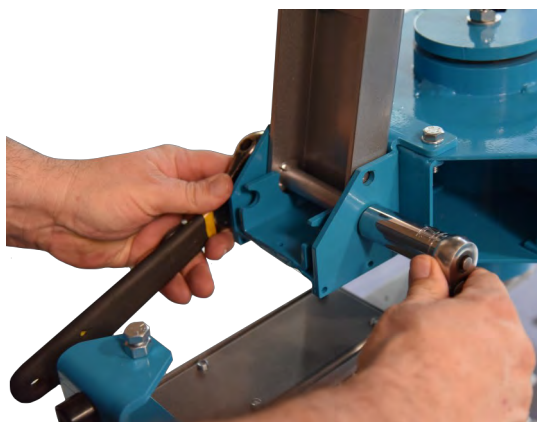

3. Push one hex bolt with a washer through the lower hole until it goes through the arm and comes out the other side. Using a 13 mm wrench, secure the bolt in place with a lock nut.

4. Repeat the process with all print heads.

Assembly

Step 3: Installing the Springs

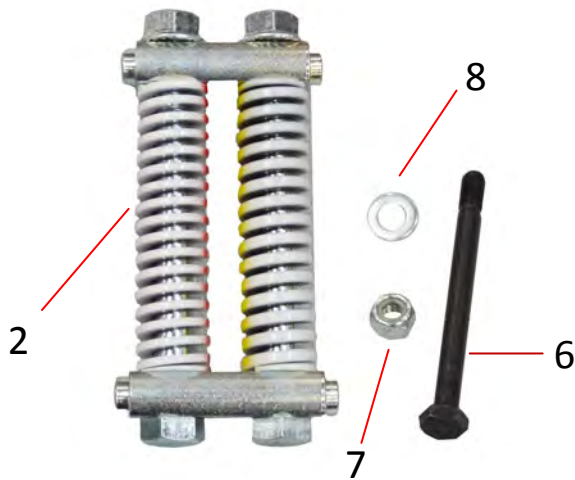

PARTS NEEDED

SPRING PACKS (Item #2)

HEX BOLTS (Item #6)

FLAT WASHERS (Item #8)

NYLON LOCK NUTS (Item #7)

TOOLS NEEDED

11/16" WRENCH

*quantity of parts depends on model being assembled

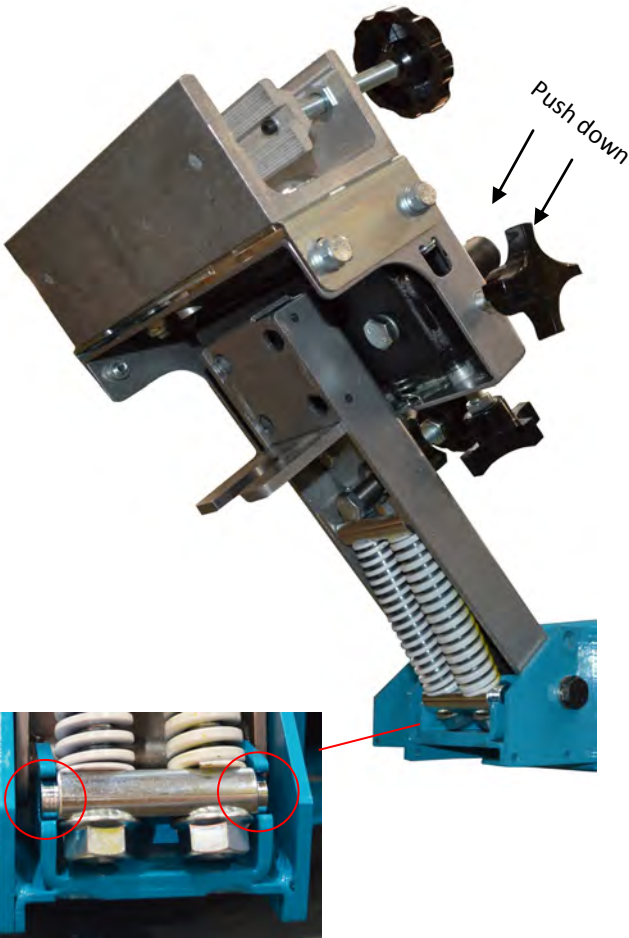

1. While print head is in an upright position, locate the empty grooves on the bottom of the swing arm. Place bottom of spring assembly into grooves as shown.
2. While Spring Pack is resting in place, lower swing arm onto top of spring assembly.
3. After installing spring assembly, push swing arm down and hold in place.

Assembly

Step 3: Installing the Springs

PARTS NEEDED	TOOLS NEEDED
HEX BOLTS (Item #6)	11/16" WRENCH
FLAT WASHERS (Item #8)	
NYLON LOCK NUTS (Item #7)	

*quantity of parts depends on model being assembled

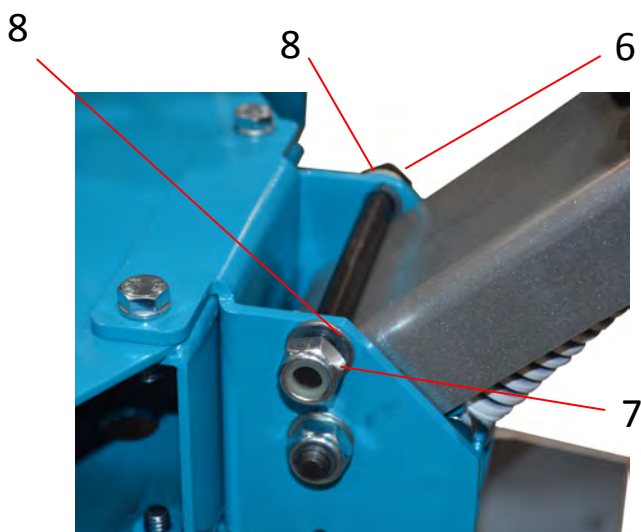

4. Install hex bolt with 1 washer from one side of swing arm.

5. Carefully release swing arm until it rests against the hex bolt.

6. Install nylon lock nut and washer on other side of bolt. Tighten with wrench.

7. Repeat with all swing arms.



Assembly

Step 4: Installing the Pallet

PARTS NEEDED	TOOLS NEEDED
ASSEMBLED PRESS	
PALLET (Item #4)	

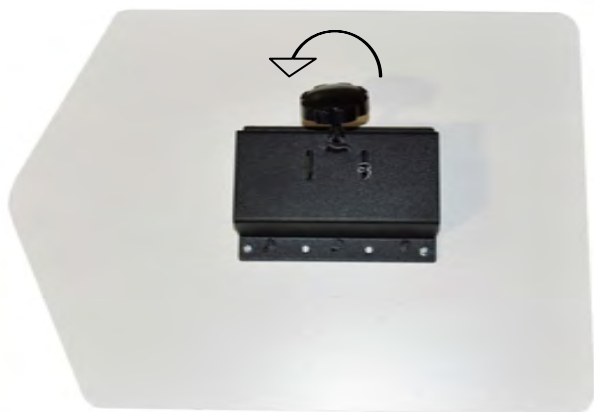

1. Take your pallet and turn the knob counter clockwise.

2. Lower the print head all the way down.

3. Take the pallet and slide it onto the pallet arm until the flat end meets the print head.



4. Twist the knob clockwise to lock the pallet into place.

Assembly

Congratulations! The Odyssey Bench Model is now fully assembled!

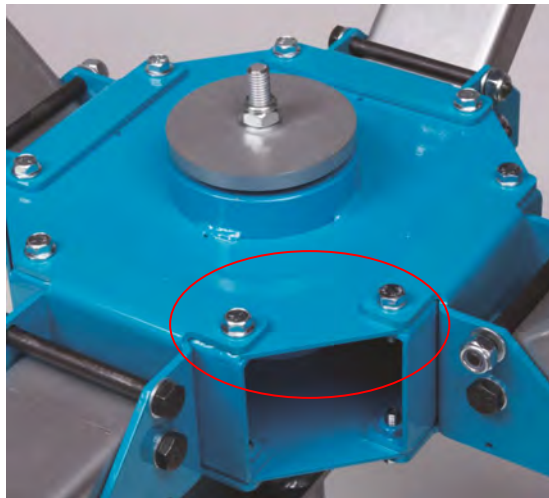

Remember, don't adjust the bolts and nuts located on the sides of the arms. They are factory set for proper leveling and alignment. This quality control process is to ensure success when assembling the press on location.

Print Head and Micro Adjustments

This will not apply to the O-1100-B

(A) Side-to-Side Micro Adjustment

(B) Micro Lockdown Knobs

(C) Screen Lockdown Knobs

(D) Y Micro Adjusters

(E) Screen Tilt Adjustment

(F) Off Contact Knob

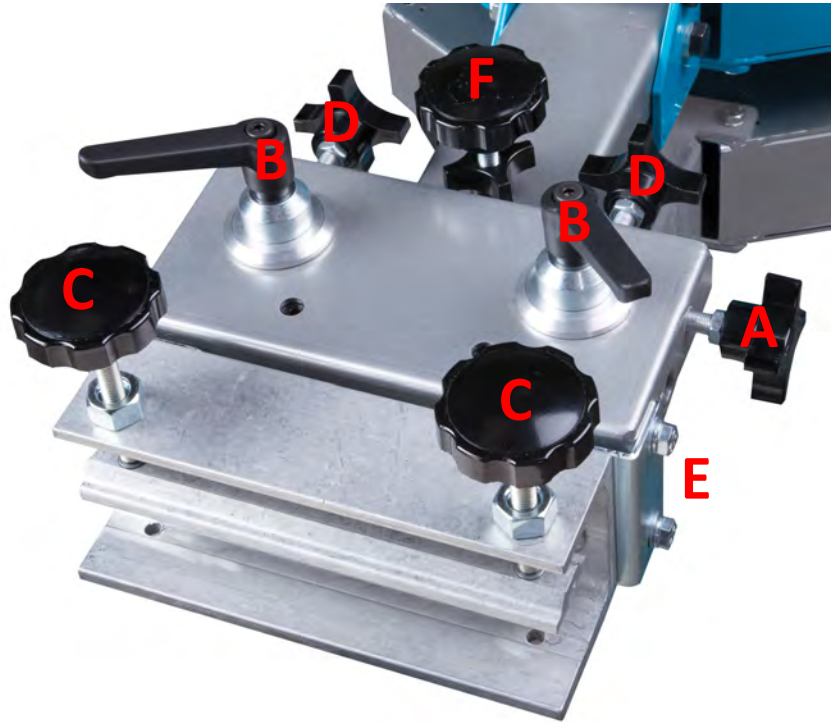

Adjusting the Off Contact: (F)

The Odyssey is set at a standard off contact, however there will be instances that require adjusting it. To readjust the off contact use knob (F) and use the 2 bolts (E) to adjust the tilt of the screen. When adjusting the tilt you will need to loosen the bolts, make the adjustments and then tighten back down.

Tip: This procedure will help set the off contact to be consistent and will require two 16" by 1"10mm thick strips of plastic (screen door window plastic). Place one strip on the pallet at the front of the screen and one at the back of the screen. Adjust the screen until it makes contact with the plastic strips in the front and the back. This procedure is helpful because it shows if the front end of the screen is parallel with

Adjusting the Screen Tilt: (E)

To start, loosen the two screen tilt bolts (E) with a 1/2" wench. Press the front of the screen until it makes contact with the plastic off contact strip. Next align the rear of the screen until makes contact with the rear plastic off contact strip. If the front and rear off contact strips are not aligning with the ends of the screen. After the off contact is consistent, tighten the two screen tilt bolts (E).

Print Head and Micro Adjustments

This will not apply to the O-1100-B

(A) Side-to-Side Micro Adjustment

(B) Micro Lockdown Knobs

(C) Screen Lockdown Knobs

(D) Y Micro Adjusters

(E) Screen Tilt Adjustment

(F) Off Contact Knob

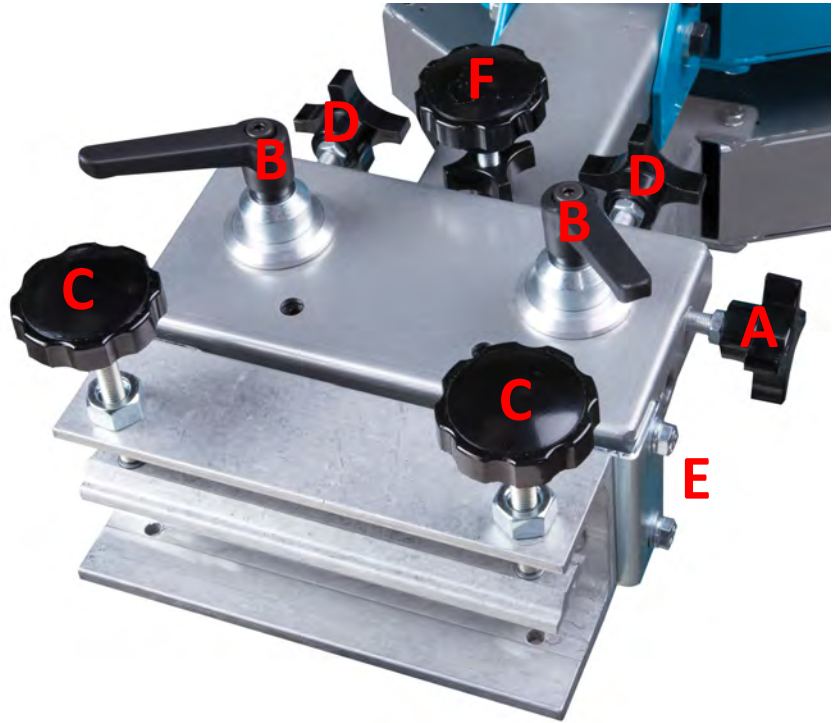

Using the X and Y Micro Adjusters: (D)

Always loosen the micro lockdown knobs (B) before adjusting the micros. To adjust the registration, turn the X and Y micro adjusters (D). To move the screen left/right or up/down use the micro adjusters (D). To move the screen up/down without moving it to the left/right, turn both micro adjusters (D) at the same time. After adjustments are finished tighten the micro lock down knobs (B), but don't over tighten.

Using the Side-to-Side Micro Adjuster: (A)

Always loosen the micro lock down knobs (B) before beginning the adjustment. Turn the side-to-side micro adjuster to move the screen side to side, to properly set it must be used in conjunction with the X and Y micro adjusters (D). To utilize the full range of movement both sets of adjusters must be used. Always center the micros either after completing a job or beginning one, because it will save a lot of movement.

Placing a Screen: (C)

To place a screen in the print head, loosen the two screen lockdown knobs (C) and raise the screen lockdown clamp bar until the screen can fit in. Then push the screen all of the way to the back of the screen clamp. After the screen is properly placed tighten the two screen lockdown knobs, but don't over tighten.

Tip: When using a back clamp printing press always measure the design height from the back of the screen, to confirm the design will register even when using different size screens.

Print Head and Micro Adjustments

This will not apply to the O-1100-B

RED: Y Axis Micro

BLUE: X Axis Micro

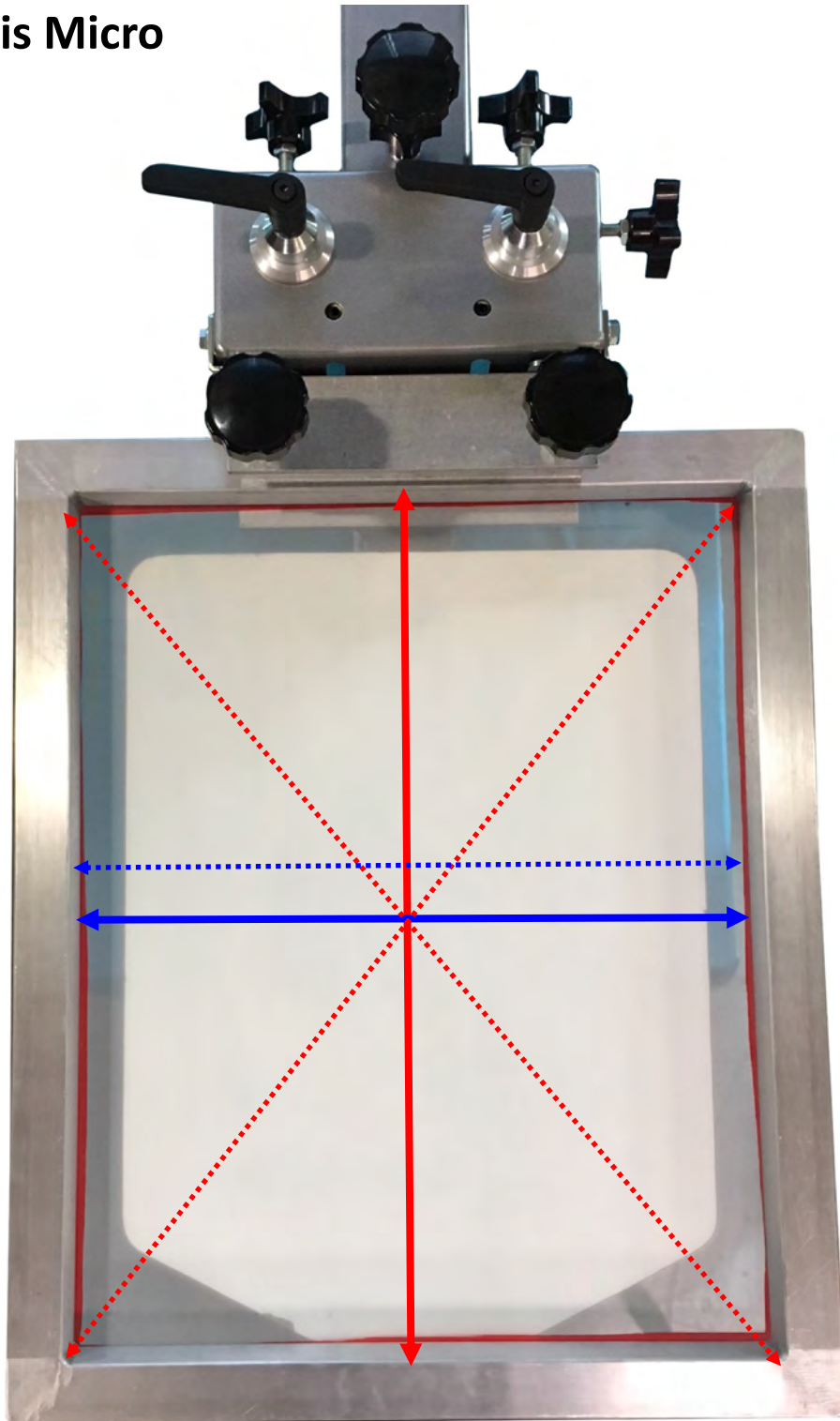

Maintenance and Troubleshooting

The Odyssey line of printing presses does not require much maintenance, but periodic lubrication and cleaning will ensure smooth operation and extended life of the components. Wipe the press daily to remove spray adhesive and lint. Do not let the spray adhesive and lint accumulate.

Lubricating the Micros

To lubricate, use heavy duty wheel bearing grease. Unscrew the (B) micro lock down knobs and both of the nuts that attach the micro adjusters to the micro plate, lift up a little and put grease under the micro plate to provide easy movement of the micros.

To lubricate the micros, back off the adjusters so most of the thread shows, apply a small dab of grease and work into the threads. Then screw down to reveal the other side and then repeat for the other side. After all of this, re-center the micros.

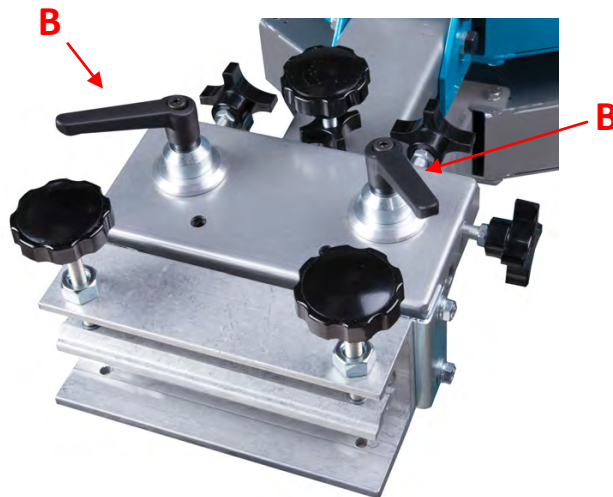

Cleaning

To clean the press, avoid using alcohol based solvents. Oil based paint thinner is better, because it won't cut and dry out the grease.

Troubleshooting

If there are issues turning any of the knobs or micro adjusters, check to see that they are not gummed up with spray adhesive or ink. If the carousel becomes stiff or too easy to rotate, check to see that the top tension nut is not too tight or loose because it will determine if the tapered bearings need grease. Take off the jam nut to reach the resistant nut.

Maintenance

Lubricating the Carousel Tapered Bearing

This will not apply to the O-1100-B

It is important to lubricate the top and bottom of the carousel tapered bearing at least twice a year. Lubrication may also be necessary if the rotation bearing becomes tight or uneven.

1. Use a wrench to remove the bolt from the Center Tapered Bearing. Lift the cap off to expose the bearing.
2. Lift the carousel wheel off of the center shaft.
3. Take a generous amount of grease and pack it onto the top and bottom of the center shaft. Remove the tapered bearing and work the grease onto the bearing separately. Be careful not to damage the race on the bearings.
4. Once complete, return the bearings and the carousel wheel back into place. Put the cap back and tighten the bolt with a wrench.

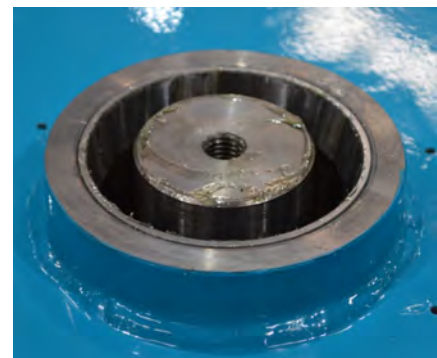
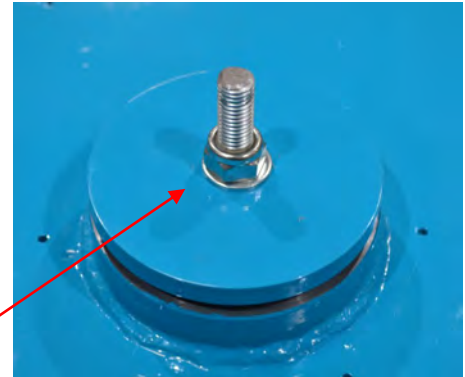

Limited Warranty

Although every effort has been made to provide accurate specifications, Workhorse Products does not assume any liability for damages, whether consequential or incidental, that may result from the use or misuse of the indicated specifications. Workhorse Products requires the use of a licensed industrial electrician for the installation of electrical service to equipment requiring electrical power.

Workhorse Products reserves the right to alter specifications in the manufacture of its products. It is understood and agreed that Seller's liability for any equipment whether liability in contract, in tort, under any warranty, in negligence, in strict liability or otherwise shall not exceed the return of the amount of the purchase price paid by Buyer. Notwithstanding the foregoing provision, under no circumstances shall Seller be liable for special, indirect or consequential damages. The price stated for the equipment is a consideration in limiting Seller's liability. No action regardless of form, arising out of the transactions under this Agreement may be brought by Buyer more than one (1) year after the cause of action has occurred. Our warranty is specified is exclusive and no other warranty, whether written or oral, is expressed or implied. Workhorse Products specifically disclaims the implied warranties of merchantability and fitness for a particular purpose. Equipment manufactured or sold by Workhorse Products is warranted against defects in workmanship and materials for a period of one year from receipt by customer. All warranties initiate from date of shipment to original customer. Replacement parts are covered for the term of the equipment warranty period. Parts not under warranty are covered for thirty (30) days from receipt by customer. Any part found by Workhorse Products to be defective in material or workmanship within the stated warranty period will be replaced or repaired at Workhorse's option without charge.

AFTER OBTAINING AN RMA# SEND RETURNED FREIGHT PREPAID TO 3730 E. Southern Avenue, PHOENIX, AZ 85040 USA.

Written authorization must be obtained from Workhorse before any part will be accepted. Replacement parts are sent out freight collect.

Parts sent out prior to receiving defective require a credit card hold for cost plus freight. Upon return of defective part, if it is deemed that the part was not damaged by customer but failed, the cost of the replacement part will be refunded.

This warranty does not extend to expendable parts such as filters, fuses, elements and brushes. Workhorse does not warrant failure of parts or components resulting from misuse or lack of proper maintenance. Installation, inspection, and maintenance costs are the sole responsibility of the purchaser.

Registration Form	
Company Name: _____	Contact Name: _____
Address: _____ _____	Phone Number: _____
City: _____	Fax Number: _____
State: _____	Email : _____
Country: _____	Cell Number: _____
Zip Code: _____	Serial Number: _____
Model Number: _____	Date Recivied: _____
Date Purchased _____	

Please Fax Registration Form for warranty to take place