

Year of Manufacture: 20 _____

Original Instructions



E-1000/E-2000 Exposing Units

Assembly and Operation Instructions



E2-2536



E2-5236

Contents

	Pg. #
• Introduction, Machine Specifications	2
• Safety Information	3
• Assembly Instructions	4-5
• Operating Instructions	6
• Maintenance	7
• Troubleshooting	8-10
• Emulsion Tips	11-12
• Warranty/Terms and Conditions	13

Vastex International, Inc.
 7 Emery St.
 Bethlehem, Pa. 18015 USA
 Phone# 610 625-2702 Fax# 610 625-2775
 Web Site www.vastex.com

Authorized Representative in Europe:
 Certification Experts BV
 Nieuwstad 100 1381 CE Weesp,
 The Netherlands
 Tel : + 31 (0) 294 – 48 33 55
 Fax : + 31 (0) 294 – 41 46 87

Electrical Drawing #: _____ Revision: _____

Serial Number: VTX Date: ___/___/___

(Please log your machine's serial number and date of purchase for future reference.)

Vastex E-mail assistance

Purchasing & Product Info:
sales@vastex.com
 Electrical Support:
stech@vastex.com
 Tech Support, Mechanical Setup, and Operation:
techsupport@vastex.com
 Screen Printing Issues & Support:
printech@vastex.com

Introduction

Vastex Exposing Units (UV Exposure Systems)

Thank you for purchasing your printing equipment from Vastex International Inc.

Vastex has been designing and building printing equipment since 1960. We have knowledge and experience, and are proud to supply the printing industry with quality equipment at an affordable price. You can be confident your purchase will give you years of trouble free service.

Machine Specifications & Part Numbers

	E2-2536	E2-5236	E1-2536	E1-5236
Overall Size (lid closed) Width x Depth x Height	32.75" x 37.75" x 14" (83 x 88 x 36 cm)	65.3" x 53.3" x 44.5" (166 x 125 x 113 cm)	32.75" x 37.75" x 14" (83 x 88 x 36 cm)	65.3" x 49.3" x 44.5" (166 x 125 x 113 cm)
Weight	210 lbs (95.5 kg)	345 lbs (156.8 kg)	210 lbs (95.5 kg)	345 lbs (156.8 kg)
Screen Capacity	25" x 36"	52" x 36"	25" x 36"	52" x 36"
Power Requirements	120v: 60Hz @ 3.5 Amps 240v: 50/60Hz @ 2 Amps	120v: 60Hz @ 10 Amps 240v: 50/60Hz @ 5 Amps	120v: 60Hz @ 3.5 Amps 240v: 50/60Hz @ 2 Amps	120v: 60Hz @ 8 Amps 240v: 50/60Hz @ 4 Amps
Vacuum Pump	1/4 HP Rocking Piston Pump (120/240V P/N: 04-02-060)	61 CFM Ring Blower (120/240V P/N: 04-02-085)	1/4 HP Rocking Piston Pump (120/240V P/N: 04-02-060)	1/4 HP Rocking Piston Pump (120/240V P/N: 04-02-060)
Control Board	PCB P/N 04-01-135	PCB P/N 04-01-135	PCB P/N 04-01-135	PCB P/N 04-01-135
Glass P/N	P/N: 04-08-061	P/N: 04-08-063	P/N: 04-08-061	P/N: 04-08-063
Light Source	LED BAR P/N: 04-08-054	LED BAR P/N: 04-08-054	UV Black Bulb P/N: 04-08-062	UV Black Bulb P/N: 04-08-062
Power Supply	P/N: 04-08-055	P/N: 04-08-055	P/N: 04-03-266	P/N: 04-03-266
Vacuum Blanket	P/N: EUB-2536	P/N: EUB-5236	P/N: EUB-2536	P/N: EUB-5236
Lid Seal	P/N: 04-08-039	P/N: 04-08-039	P/N: 04-08-039	P/N: 04-08-039
Floor Model/ Tabletop	Standard: Floor Model	Standard: Floor Model	Standard: Floor Model	Standard: Floor Model
Warranty	3 Years; Manufacturer Defects	3 Years; Manufacturer Defects	3 Years; Manufacturer Defects	3 Years; Manufacturer Defects

Essential Characteristics of tools which may be fitted to this machinery:

This equipment is not designed to be used with any additional attachments or tools, other than as specifically listed in this manual.

Safety

Intended Use:

This equipment is intended for the purpose of exposing screens and films with UV light in conjunction with UV sensitive emulsions.

Safety:

- The operator should read and understand this manual before operating this equipment. Store manual and safety information near equipment for easy access to operators.
- Never leave equipment unattended while in operation.
- Children and pets must be kept clear of the work area.
- Do not store any objects on top of the exposing unit.
- Unplug power cord before removing glass or entering control box.
- Do not operate if any guard or cover has been removed.
- Do not operate if power cord is damaged.
- Safe Operating Temperature (Ambient): 55°F-100°F (13°C-38°C).
- Do not attempt to defeat safety interlocks.
- Noise and Vibration: This noise level produced by this equipment does not exceed 70 dB(A).

**** WARNING HANDLE GLASS WITH CARE ****

- Wear gloves when handling the glass
- Lay glass only on a flat protected surface

General Information

- Exposing Unit must be on a flat surface to eliminate stress on the glass.
- Caution! Screens must be free of sharp edges. All surfaces coming in contact with vacuum blanket should be rounded and smooth.
- UV Lights are used in this machine. The lights should Not Be viewed during operation without eye protection.
- Keep the lid in the raised position when not in use. It will increase the life of lifting cylinders and the rubber blanket.

Tools Required

- Philips Head Screw Driver
- 7/16", 9/16" & 5/8" Wrenches
- **OR METRIC:** 11mm, 15mm, 16mm

Assembly

Getting started:

Your Exposing Unit has been fully assembled and tested in our factory. Both lid lifting cylinders have been removed from their upper mounting stud and secured to the side of the cabinet. Be careful not to damage the rubber vacuum blanket when removing the Exposing Unit from its crating.

It is best to keep the lid locked closed when lifting the exposing unit. Carefully remove the unit from its crate and place it on a suitable surface. It is important that the surface be flat, an uneven surface can put stress on the glass causing it to crack.

Placing the equipment into service and operating the equipment:

To place equipment into service, follow steps 1-4 on Page 5.

To operate your exposure unit, follow the instructions on Pages 6-8.

For troubleshooting and maintenance instructions see pages 9-12.

Stability during use, transportation, assembling, dismantling when out of service, testing, and foreseeable breakdowns:

This equipment is designed to be stable under all foreseeable conditions if the instructions provided herein are followed. Do not place the unit into positions not shown in this manual (e.g., on their sides) and do not operate with any parts removed unless necessary for troubleshooting.

Safe transport, handling, storage: when the equipment is transported, it should be moved by two or more people. No other special precautions are required. Refer to page 2 for unit masses.

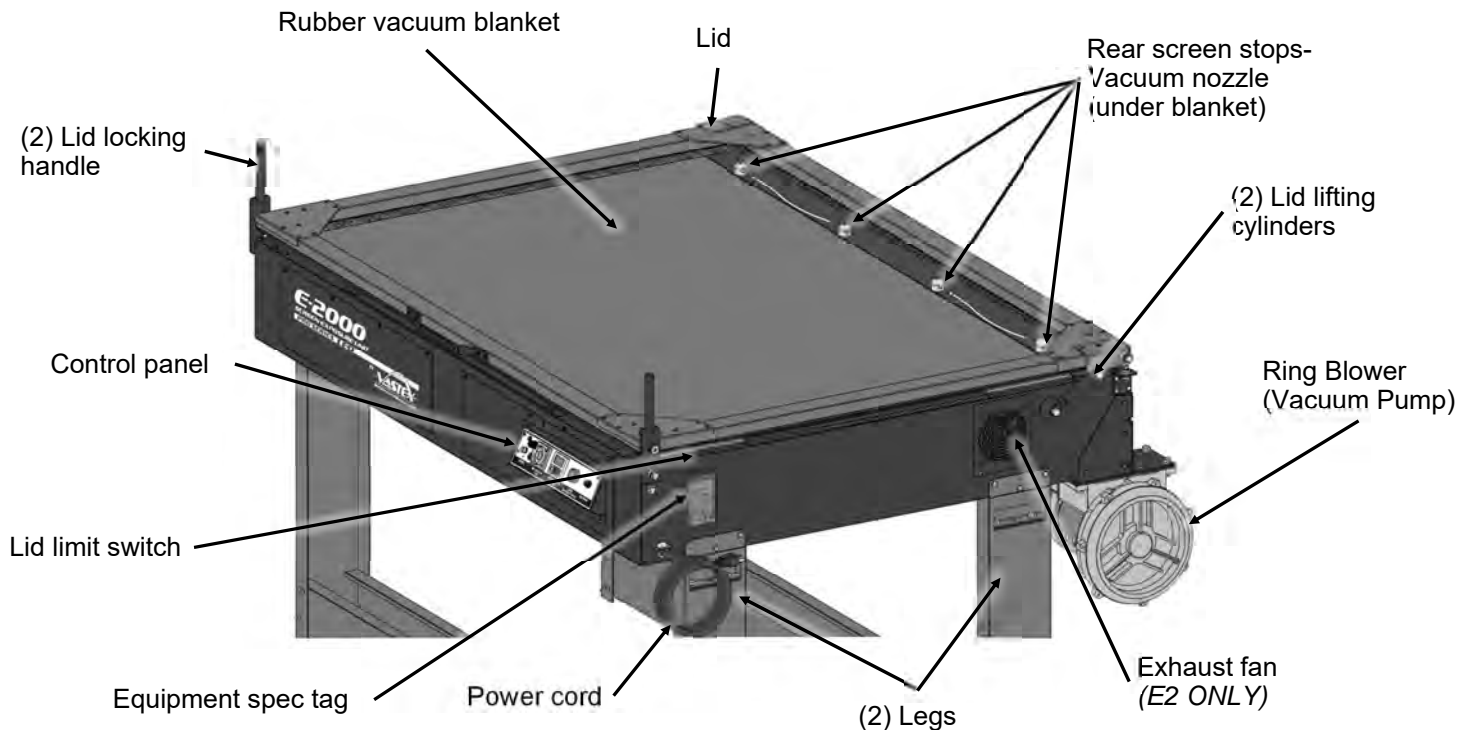

E2-5236 shown
Components may be located elsewhere on other models.

Assembly Cont'd

- 1) Install legs, if included. Place Legs on a clear spot on the floor, 28.5" (72.5cm) apart as shown in picture 1.

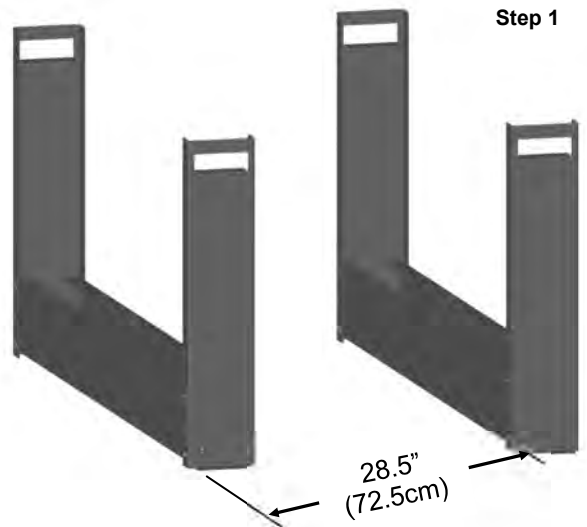

- 2) Lock lid handles as shown. Carefully lower the exposing unit down onto the legs. Two people are required to do this as caution must be taken to not damage the machine's glass or rubber blanket.



- 3) Legs are installed with (8) 3/8" bolts and (8) 3/8" serrated nuts. Use (2) 9/16" open end wrenches and tighten all bolts well.



4) Install Lid Lifting Cylinders

Remove the acorn nut from the upper cylinder mounting studs located on both sides of the lid. Unlock and carefully lift lid far enough to slide lifting cylinders onto studs. Replace acorn nuts onto stud. Snug only with a 5/8" wrench. Do not over tighten!

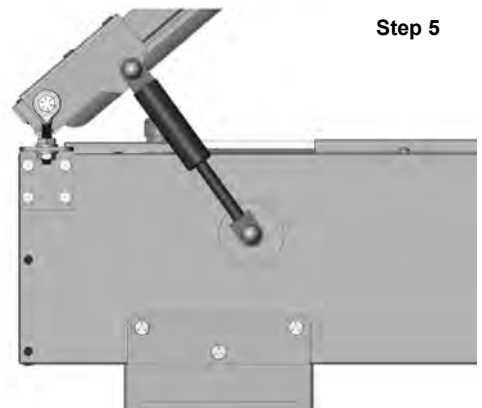

Operation

Overview:

Your Exposing Unit is equipped with LED Lights, vacuum timer, exposure timer, vacuum pump, and separate switches for main power and exposure cycle start.

The vacuum pump draws the air out from between the blanket and glass. This flattens the coated screen and positive to the glass making for a sharper exposed image.



Vacuum Timer is set to minutes. Lower right adjustment screw must be set to B.
Exposure Timer is set for seconds. The right selection must be S.

Sequence of Operation

- 1) Raise the exposing unit lid and wipe the glass surface clean with a lint free rag.
- 2) Position the screen with positive attached, onto the glass and against the two back screen stops.
Do not position any screen outside screen area indicated by the blue tape. Damage to vacuum blanket can result.
- 3) Lay the small string attached to the rear of the exposing unit over the edge of the screen to assist in achieving a good vacuum in the center of the screen.
- 4) Lower the lid and lock closed with both handles.
- 5) Turn on the power switch.
- 6) Set the Vacuum Time. (See Tips).
- 7) Set Exposure Time. (See Tips).
- 8) Start Exposure Cycle. The vacuum pump will start. after the vacuum timer has reached preset time the LED lights will start. After the exposing time has expired, the lights and vacuum pump will automatically shut off. The screen is now exposed.
- 9) Unlock the lid to break the vacuum and remove the screen.

Tips

Vacuum Time: (for each size screen)

Place desired size blank screen properly onto the glass. Lock lid and set vacuum time to 1.5 minutes. Start cycle and record the time it takes to flatten the blanket to a size larger than your positive. If unsure, wait until blanket is flat to within 2" (5cm) of frame.

Exposure Time:

A full and complete exposure will be effected by several variables listed by importance.

- 1) Type and brand of emulsion
- 2) Thickness of stencil (qty. of coats or capillary film thicknes)
- 3) Mesh color
- 4) Humidity

For this reason the only proper way to determine the correct time for a full and complete exposure is to use a "Exposure Calculator". Several types of calculators are available, contact your supplier to determine which is best for you.

Approximate setting for single part or "Pure Photopolymer" is: 20 – 40 seconds.

Approximate setting for "Dual Cure": 2 – 5 minutes.

Maintenance

Do Not allow objects to contact the UV lights.

Wear gloves when handling the glass. Glass is tempered and although strong, can shatter if the edges are subjected to an impact.

Glass Removal / Installation

There are three glass retainers. One on each side to square the glass to the rear seal and one in the front with special cams. The cams are used to gently push the glass back against the rear seal.

- 1) Remove the cams and front retainer. Slide the glass towards the front to remove. Carefully set glass on a flat, protected surface. The cams are used to gently push the glass back against the rear seal.
- 2) It is important to keep the inside of the cabinet clean. Vacuum out any loose debris from inside the cabinet. Refer to the replacing a light bar if needed.
- 3) **Reinstalling the glass.**

Before installing the glass, switch the vacuum pump on and off to verify it is functioning properly. Clean both sides of the glass with glass cleaner and a lint free rag. Vacuum inside of cabinet. Position the glass seal side down, blue tape towards the front, on the front edge of the cabinet, and between the side retainers. Slide glass back until it contacts and it seated squarely against the back seal. Place the front glass retainer and the three cams against the glass front. Install the screws but only snug the screws. Using a 1/4" flat screw driver in the cam slots, rotate each cam to push the glass back. Do not over tighten the cams but apply enough pressure to make a seal. Now tighten the center screws. If the vacuum leaks, go back and tighten the cams a bit more.

- 4) Inspection of LED light bars should be conducted monthly. See page 11, Step 1, for instructions.

Inspection of UV Black bulbs should be conducted bi-monthly. See page 12, Step 1, for instructions.

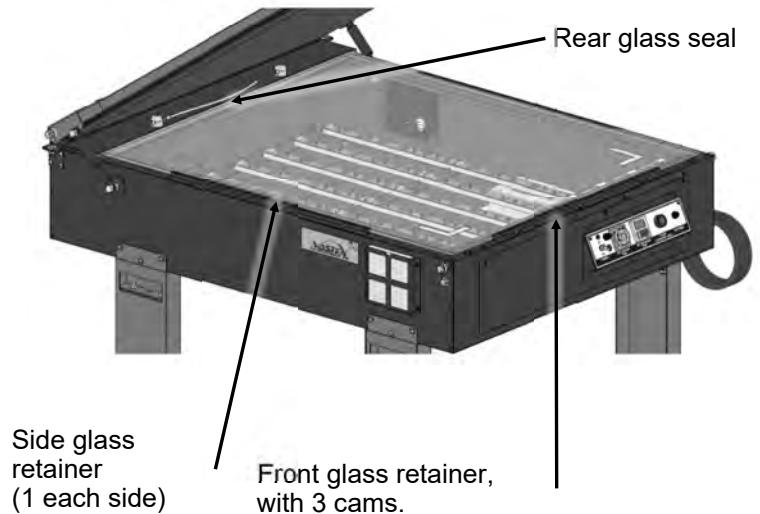

Note: The glass must be tight against the back glass seal in order to make a good vacuum. Special cams help to apply pressure. Do not over tighten.



Troubleshooting

Loss of Vacuum

This can be caused by several problems. Check the following items in order listed.

- 1) Verify that vacuum pump is running.
- 2) Examine the rubber blanket for holes or cuts.
- 3) Check that the holes in the screen stop nozzles are not blocked. Turn on the pump and verify that there is vacuum through the right stop (Check for vacuum on all nozzles of the E2-5236).
- 4) Check that the clear tube attached to the vacuum pump under the light box. This is the vacuum pump exhaust tube.
- 5) (E2-5236 Only) Verify that the four tubes attached between the vacuum manifold and the nozzles are connected and are not pinched.
- 6) Verify that the back glass seal is not damaged. If it is not try tightening the front cams just slightly. If this does not work, pull the glass away and inspect the seal, then reseal the glass squarely against the back seal and retighten the front cams.
- 7) There is a foam seal around the perimeter of the lid between the rubber blanket and lid frame. With the lid locked down, check that the lid seal and blanket is contacting the glass at all four sides. If this seal is not contacting the glass it will be necessary to adjust the lid lower. Proceed as follows (pictures below for reference).

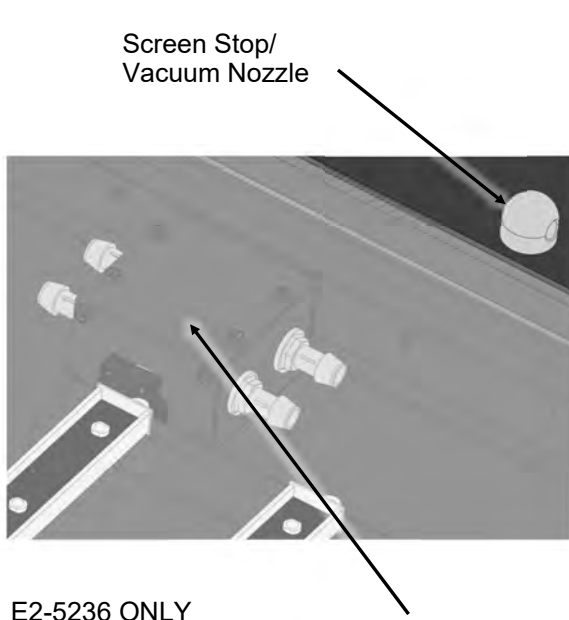

Rear Lid Adjustment Nuts

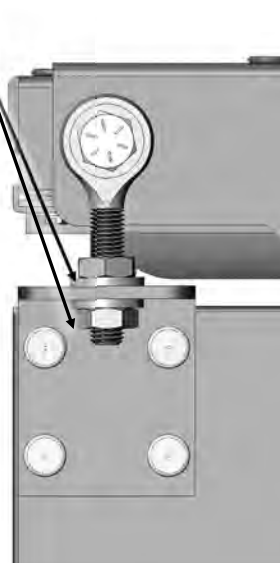

Rear Lid Adjustment

Loosen 1/8 turn for adjustment

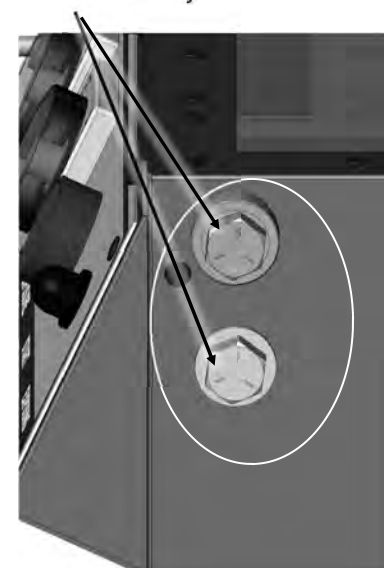
Front Lid Adjustment
(All models)

Troubleshooting Cont'd

Light Bar Replacement / Installation

Note:

It is important to wear dark shaded and UV rated eye protection while testing any UV Lights.
Do Not allow objects to contact the UV lights.

- 1) Inspection of LED light Bars. Lift the lid and override the safety switch on the left side of the cabinet by depressing with your finger or a pencil. Put your sunglasses on and press the green start button. With the lid up view if ALL lights are working. If not, proceed to step 2. Contact factory for replacement light bar.

It may be possible to expose screens with LED lights out, but a repair is needed to ensure optimal performance.

- 2) Unplug main power cord.
- 3) Remove exposing unit glass, see Maintenance section for glass removal.
- 4) Open the maintenance door in the front of the unit by removing the (4) #8 sheet metal screws with a 1/4" driver.
- 5) Disconnect the defective light bar by simply removing the blue and brown wires, then remove the top, #8 nut holding down the light bar.
- 6) Installing the new light bar. Seat the light bar in its corresponding slot. Re insert the blue and brown wires just as they were in the defective light bar.
- 7) Test the new light bar. See above section 1.
- 8) Secure the bar with the #8 nut.
- 9) Close the maintenance door and replace the #8 sheet metal screws.

Depress Limit Switch when testing lights



Step 1

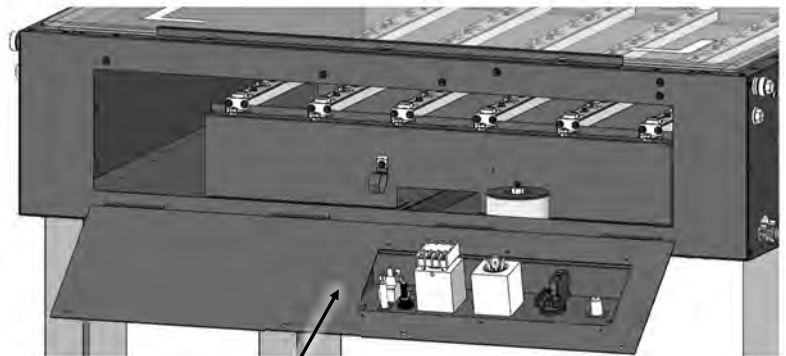

Maintenance door

Step 4

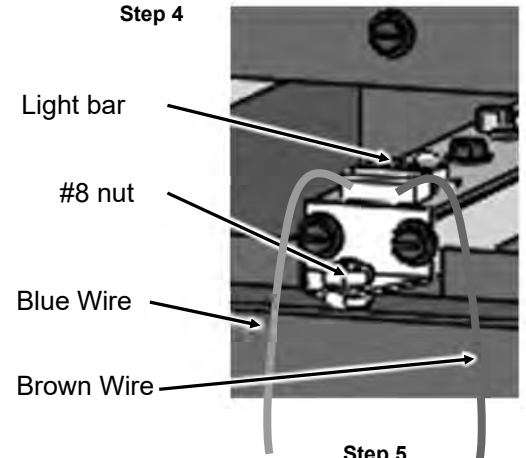

Step 5

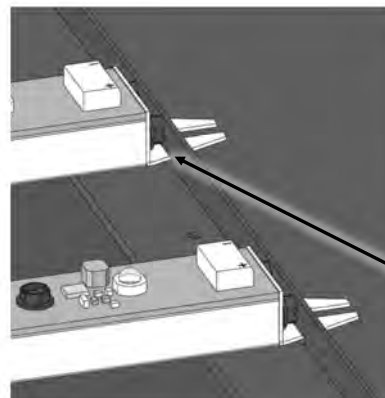

Slot in back

Step 6

Troubleshooting Cont'd

UV Black Light Bulb Replacement / Installation

Note:

It is important to wear dark shaded and UV rated eye protection while testing any UV Lights.
Do Not allow objects to contact the UV lights.

- 1) Inspection of UV Black Bulbs. Lift the lid and override the safety switch on the left side of the cabinet by depressing with your finger or a pencil. Put your sunglasses on and press the green start button. With the lid up view if ALL lights are working. If not, proceed to step 2. Contact factory for replacement lights.

Depress Limit Switch when testing lights



Step 1

- 2) Unplug main power cord.
- 3) Remove exposing unit glass, see Maintenance section for glass removal.
- 4) Open the maintenance door in the front of the unit by removing the (4) #8 sheet metal screws with a 1/4" driver.
- 5) Turn Bulb 1/4 turn and lift straight up to remove.
- 6) Install new bulb by placing the bulb in position, and lightly turning bulb 1/4 turn until bulb pins are seated.
- 7) Test the new bulb. See above section 1.
- 8) Close the maintenance door and replace the #8 sheet metal screws.

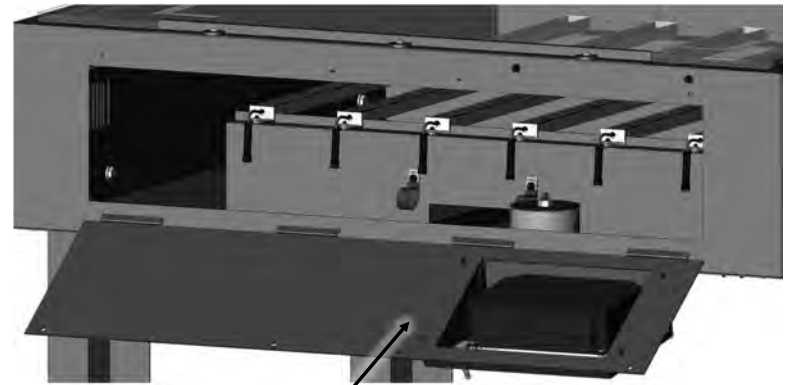

Maintenance door

Step 4

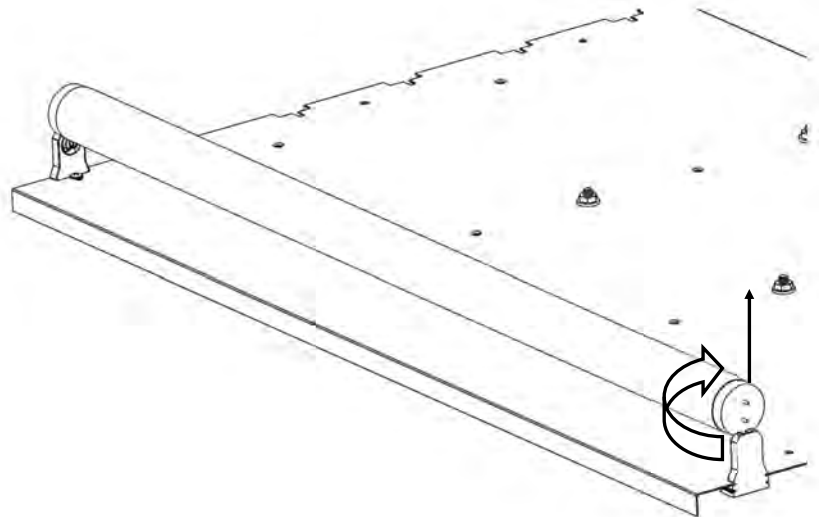

Emulsion information for the screen printer

A technical information article by Douglas Grigar

Screen printers have available six types of photoreactive stencil materials. There are three direct emulsion choices, diazo, diazo/photopolymer (dual cure), and SBQ-photopolymer. There are also three photo reactive film choices, indirect film, direct/indirect film, and photoreactive capillary films.

Diazo emulsions are the least expensive and the first of the three emulsion types available on the market. Diazo emulsions are mid range in available exposure latitude and can have good edge definition. Drawbacks are that many require hardeners for long runs or water resistance lower solids content is often needed for reasonable viscosity.

Diazo Photopolymer emulsions are hybrids of the diazo and photopolymers and are also called dual cure. Dual cure emulsions are the newest available emulsions. Due to the hybrid nature they have the largest available feature and quality range. Dual cure emulsions will have the largest exposure latitude and are available in various levels of water and solvent resistant features. Dual cure emulsions generally have the best resolution, definition, and bridging qualities. Dual cure emulsions are midrange in price, and higher solids content versions are available with reasonable viscosity.

SBQ- Photopolymer emulsions are very fast in their exposure speeds but also have the smallest exposure latitude. They are pre mixed and have the longest shelf life. Pure photopolymer emulsions are the most expensive and are best matched with high quality single point exposure systems. Pure photopolymer emulsions have good resolution, definition, and bridging qualities. Pure photopolymer emulsions have the highest solids content available with reasonable and often excellent viscosity.

The solids content in an emulsion does

example would be that pure photopolymer emulsions are available in very high solids content with low viscosity. Emulsion viscosity can also change with temperature. Lower temperatures cause the emulsions to thicken. Solids content less than 30% with low viscosity are often difficult to coat without a mess. In addition, lower solids percentage will require multiple coatings to achieve reasonable mesh coverage.



Fig. 1

Emulsion Over Mesh or EOM is a measurement of the emulsion thickness on the face or substrate side of the mesh. EOM is a percentage of the mesh thickness. (Fig. 1) Too low of an EOM ratio will prevent a good gasket seal, prevent good detail resolution, and increase chances of saw tooth edges. Manufacturers recommend an EOM ratio of 10 to 20 percent.

With an emulsion stencil, more is not better. Too much emulsion on the face of the screen can cause difficult ink transfer and details can break down in a run. Emulsion drip from the mesh while drying is a definite indication that the coated emulsion is too thick.

Your emulsion manufacturer can recommend a coating procedure for each mesh count using a rounded or sharp coating edge.



Fig. 2

The step coating procedure (Fig. 2) is used to coat a screen to find your best coating technique for that mesh count. The step coating procedure starts with a stroke on the face of the mesh. Then

coat the squeegee side once over the entire screen. Coat again the squeegee side on only two thirds of the screen, then coat again one third of the squeegee side (all wet on wet).

Dry your screen as normal. When dry, face coat with the sharp edge of the squeegee two thirds of the screen from a crossing direction (perpendicular) then dry face up. When the screen is dry apply the last coat of emulsion on the face side covering only one third of the same direction as the last face coat, then dry. With the face coatings there will be nine examples of coating thicknesses. Pick an exposure time that fits the median coating technique and expose the screen with a test positive that covers all of the coating changes.

Wash out and dry as normal. Now you can view the emulsion with a loop or microscope. Inspect the changes in thickness, then print with this screen and inspect the printed results. With the printed results compared to the visual inspection, the best coating technique for that mesh count can be determined. Standardized mesh thread thickness and weave for each mesh count is needed for consistent and reliable results.

The step coating procedure can be used while eliminating some of the steps, or replace the face coatings with all wet on wet coating strokes.

All manufacturers recommend drying coated screens with the face down (squeegee side up) in a horizontal position. A slightly elevated temperature (not over 110 deg. F.), in a filtered drying room or cabinet, will dry screens in record time, often less than half an hour. A dehumidifier will drop emulsion drying time further.

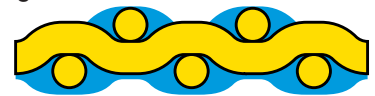

Fig 3

Once the screen is dry, direct emulsion will dry and conform to the profile of the mesh fabric causing small hills and dips in the surface. The smoothness of the dry emulsion can be measured and is represented by the term Rz value. (Fig. 3) The lower the Rz measurement number the smoother the surface.

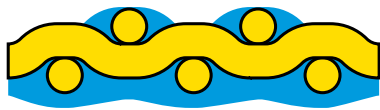

Fig. 4

Surface smoothness can affect your substrate to stencil gasket. The lower Rz numbers will be produced only by machine coating or film products. Direct/indirect and capillary films will produce the lowest Rz numbers possible for screen stencils. High solids content emulsions and face coating (second or more coats of emulsion over dry first coatings) can also lower your Rz measurements. (Fig. 4) Exact EOM and Rz numbers can only be measured by special testing equipment.

Indirect film products are presensitized emulsions on film. They are produced to expose and develop before they are attached to the screen mesh. Indirect film has fallen out of general use as products that are easier to use and have superior reproduction properties are now available.



Fig. 5

Capillary films are a photosensitive emulsion layered onto a film backing. (Fig. 5) The name is indicative of the action that causes the adhesion, capillary action. With wet screen fabric the film will draw into the mesh when placed in contact with the face of the screen.

Capillary films suffer from past bad reputation for delamination (Fig. 6) the current products available are capable of long runs and excellent detail. Capillary films produce the lowest Rz numbers possible and can save large amounts of screen room production time.

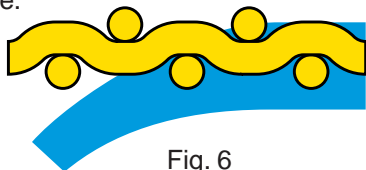

Fig. 6

Capillary films are best applied with the

(emulsion up) on a hard flat surface. (Fig. 7)

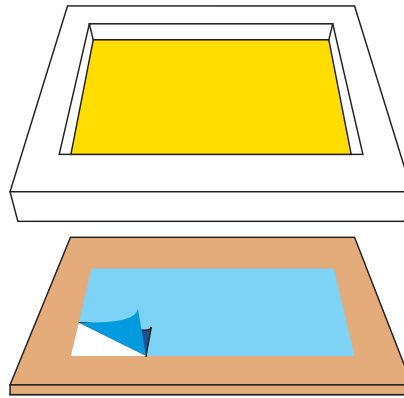

Fig. 7

Place a screen (squeegee side up) onto the film, lightly mist the mesh with a spray gun until the screen starts to draw up the capillary film into the fabric. (Fig. 8)

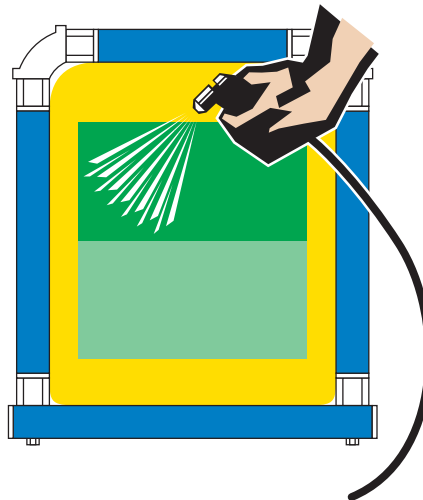

Fig. 8

Direct/indirect film products (combination stencils) are two-part film and emulsion combinations. Films assure low Rz numbers and high detail print quality. Direct emulsions produce high stencil durability. Direct/indirect film systems combine the best features of direct emulsion and film products, creating a strong, high definition stencil that will make longer runs possible with direct emulsion.

Direct/indirect film products require a coating of direct emulsion. Then the film can be adhered to the face (substrate side) of the screen. One method is to coat the screen (one stroke on each side of the screen) then place the screen (squeegee side up) on the film (emulsion side up) and stroke the squeegee side of the screen with a low

pressure stroke with a soft squeegee. (Fig. 9) The use of newsprint on your work surface will help with clean up.

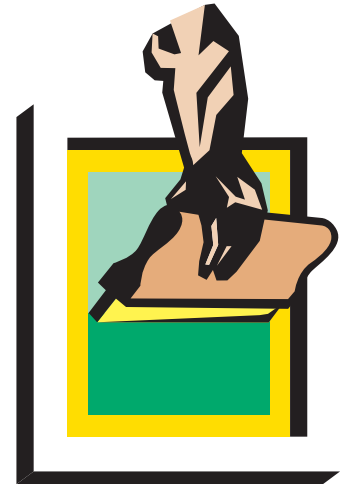

Fig. 9

Stay consistent and you will be able to predict your results with greater accuracy. Your goal should be consistency, predictability, and repeatability.

Graphics and text copyright 2002
Douglas Grigar dgrigar@hotmail.com

Vastex Warranty

Doc#01-00-005D Revised 2/20/2018

(1.) Vastex, hereinafter referred to as "seller" warrants only to its original "purchaser", who holds a copy of the original invoice and is the original end user of the equipment in question, its new equipment against manufacturer defects in materials or workmanship on a pro-rated basis. Warranty period begins from date of shipment to the buyer and will only apply to customers paid in full. Warranty periods are as follows: one (1) year for E-1000, three (3) years for all other complete machines (including F-Flash), fifteen (15) years for infrared heaters (excluding F-Flash) installed by Vastex in a new dryer, three (3) years for replacement infrared heaters, and one (1) year for replacement parts. Rubber blankets, light bulbs and glass on exposure units are particularly subject to wear while in use. Wear is not covered by this warranty but as stated above only manufacturers defects are covered. All sales made through Vastex dealers must be certified by that dealer before a warranty replacement is issued. All equipment is thoroughly tested and inspected before packaging. This warranty does not cover minor cosmetic damages that occur during shipment that do not affect the functionality of the equipment.

(2.) **This warranty is expressly contingent upon the buyer delivering to seller, at the address below, with all transportation charges prepaid, the part or parts claimed to be defective within the above mentioned warranty periods stated in paragraph one. The defective part or parts will be repaired or replaced at the discretion of Vastex International, Inc. If the equipment in question is less than one (1) year old, it will be shipped to the customer at no charge, with an RGA issued by Vastex for the defective part. The defective part must be shipped back to Vastex freight prepaid within 30 days or the account will be billed. If the equipment is more than a year old, the part will be shipped after we receive the defective part. If it's necessary to expedite the movement of parts and to minimize down time to the buyer, the replacement part shall be supplied on a C.O.D. basis. If testing and analysis of said part by the seller or its supplier discloses that said part is defective, the cost of said part will be refunded to the buyer on a prorated basis.**

(3.) Except as otherwise provided herein, the equipment is being sold "as-is". Final determination of the suitability of the equipment for the use contemplated by the buyer, is the sole responsibility of buyer, and seller shall have no responsibility in connection with the suitability.

(4.) All warranties implied by law, including the implied warranties of merchantability and fitness are hereby limited to manufacturer defects in materials or workmanship during the warranty period stated in paragraph one. The express warranty and remedies contained herein and such implied limited warranties are made solely to the sole warranties and remedies and are in lieu of all other warranties, guarantees, agreements, and other liabilities, whether express or implied, and all other remedies for breach of warranty or any other liability of seller, in no event shall seller be liable for consequential damages.

No person, agent, distributor, or service representative is authorized to change, modify or extend the terms hereof in any manner whatsoever.

These terms and conditions are an essential part of the transaction between the parties and constitute the entire agreement between them with respect to the same.

Some states do not allow limitation on how long an implied warranty lasts of the exclusion or limitation of incidental, or consequential damages, so the above limitation may not apply to you.

This warranty gives you specific legal rights, and you may also have other rights which vary from state to state.

Infrared heaters are the only replacement parts covered for a period of (3) years from date of shipment and contingent to receipt of payment in full.

Electrical components cannot be returned once installed unless proven defective.

Please refer to doc. 01-00-015 for specific terms and conditions of sale and the limited warranty.

Please refer to doc. 01-00-017 for V-2000HD printer warranty.

Updates: V1000 to 3 year warranty 01/09/12, Heater warranty to 15 years 01/02/2012.

TERMS AND CONDITIONS OF SALE AND LIMITED WARRANTY Doc.#01-00-015

- Buyer's order will constitute an offer in accordance with the terms hereof and such offer, upon acknowledgment of Seller, will constitute the agreement between Buyer and Seller. Buyer's order after such acknowledgment by Seller will not be subject to cancellation, change or reduction in amount, or suspension by Buyer of deliveries, unless prior to such action Buyer has obtained Seller's written consent. Notwithstanding anything to the contrary in Buyer's Purchase Order or other communications, the parties agree to be bound by these Terms and Conditions. Acceptance of the product by the Buyer shall be deemed to constitute unconditional acceptance of these Terms and Conditions.
- Any of these terms, conditions and provisions of Buyer's order which are inconsistent with Seller's acknowledgment and these Terms and Conditions of Sale shall not be binding on the Seller and shall be considered not applicable to any sale so made. No waiver, alteration or modification of any of the provisions on either side of the document shall be binding upon Seller unless agreed to in writing by Seller.
- (a) All prices are F.O.B. Seller's Plant and method of delivery and routing shall be at Seller's discretion, unless specifically otherwise stated herein. Notwithstanding any agreement to pay freight, delivery of products purchased hereunder to a common carrier or licensed trucker shall constitute delivery to Buyer and be determinative of the date and time of shipment and all risk of loss or damage in transit shall be borne by Buyer. If the Buyer fails to accept the goods from the common carrier or licensed trucker, the Seller shall be entitled to claim payment from the Buyer. Seller shall arrange for storage, the risk and the cost, including insurance costs, to be borne by the Buyer (and Buyer agrees to pay such amounts upon demand) except if the failure to accept delivery is due to any of the exceptions noted in Paragraph 4.
(b) Terms of payment shall be as stated on invoice.
- It is understood that deliveries will be made in accordance with Seller's regular production schedule. Every reasonable effort will be made to meet the Buyer's required delivery dates but Seller will not be liable for damages or be deemed to be in default by reason of any failure to deliver or delay in delivery due to any preference, priority, allocation or allotment order issued by the Government, whether Federal, State or local, or causes beyond its control including but not limited to, Acts of God or a public enemy, acts of Government, fires, floods, epidemics, quarantine restrictions, strikes, lockouts, freight embargoes, severe weather, unavailability of materials or shipping space, delays of carriers or suppliers or delays of any subcontractors. Should delay in delivery be caused by any of the circumstances mentioned in this paragraph, such extension of the delivery period shall be granted as is reasonable under the circumstances of the case. Should delay be caused by an event not specifically mentioned in this paragraph, damages will be limited to cancellation of the purchase order without penalty, and refund of any monies deposited or prepaid on the purchase order with no liability for any consequential or incidental damages.
- Seller reserves the right to increase the prices prior to Seller's acceptance of order and/or after expiration of any price quoted by Seller.
- Unless otherwise stated in writing, Seller's prices do not include sales, excise, value-added or other taxes. Consequently, in addition to the price specified herein, the amount of any present or future sales, use, excise, value-added or other tax applicable to the manufacture, sale, purchase or use of the products hereunder shall be paid by Buyer, or in lieu thereof, Buyer shall provide Seller with a valid tax exemption certificate acceptable to the taxing authorities.
- Seller reserves the right, at any time, to revoke any credit extended to Buyer because of Buyer's failure to pay for any products when due or for any other reason deemed good and sufficient by Seller and in such event, all subsequent shipments shall be paid for prior to at delivery at Seller's option.
- (a) SELLER'S LIABILITY SHALL BE LIMITED TO SELLER'S STATED SELLING PRICE PER UNIT OF ANY DEFECTIVE GOODS AND SHALL IN NO EVENT INCLUDE BUYER'S MANUFACTURING COSTS, LOST PROFITS, GOODWILL, OR ANY OTHER SPECIAL, INDIRECT, INCIDENTAL OR CONSEQUENTIAL DAMAGES, ARISING OUT OF THE AGREEMENT, THIS CONTRACT, THE SALE OF THE PRODUCTS TO THE BUYER OR THE USE OR THE PERFORMANCE OF THE PRODUCTS. Seller may at its discretion repair, replace or give the Buyer credit (pro-rated) for such defective products.
(b) Notwithstanding anything herein to the contrary, Seller shall have no liability for alleged defects with the products which are not specified in written notice from the Buyer to the Seller within thirty-six (36) months from the date of shipment of machines. Seller shall pass to Buyer any warranty received by Seller from the manufacturer of Limited Life Components, which in most cases is 12 to 18 months.
(c) Seller shall have no liability under this Limited Warranty unless Buyer has paid in full for the products. Further, this Limited Warranty is expressly contingent on Buyer's delivery to Seller, all costs prepaid, the defective part(s) within thirty-six (36) months of shipment to Buyer, together with a written statement specifying the alleged defect(s). Any replacement part(s) shall be shipped to Buyer on a C.O.D. basis.
(d) SELLER SPECIFICALLY EXCLUDES ALL WARRANTIES, EXPRESSED, IMPLIED OR OTHERWISE, EXCEPT AS STATED EXPLICITLY IN THESE TERMS AND CONDITIONS OF SALE. SELLER DISCLAIMS THE WARRANTY OF MERCHANTABILITY AND FITNESS FOR A PARTICULAR PURPOSE.
- The remedies herein reserved by Seller shall be cumulative and in addition to any other legal remedies. No waiver of a breach of any portion of this contract shall constitute a waiver of continuing or future breach of such provision or of any other provisions hereof.
- These Terms and Conditions constitute the entire agreement of the parties. No amendments, changes, revisions or discharges hereof in whole or in part shall have any force or effect unless set forth in writing and signed by the parties hereto. This contract shall not be assignable by Buyer voluntarily by operation of law or otherwise without Seller's written consent.
- This contract shall be governed and shall be construed according to the domestic laws of the Commonwealth of Pennsylvania.
- Anything herein to the contrary notwithstanding, any action for alleged breach by Seller of the contract between the parties, including but not limited to any action for breach of the warranties herein set forth, shall be barred unless commenced by Buyer within one (1) year from the date such cause of action accrued.
- This agreement shall inure to the benefit of and be binding upon the parties hereto, their respective successors and permitted assigns.
- All notices required by this contract to be given by either party shall be sent in writing or by facsimile and shall be addressed to the last known address of such other party. Notices shall be deemed to have been received on the fifth business day following deposit in the mail.**

