



WORKHORSE PRODUCTS

PRECISION SCREEN PRINTING EQUIPMENT

Owner's Manual

Powerhouse Series II



Powerhouse Series II PD5409-4 Conveyor Dryer

67-1462 REV 517

Table of Contents



I. Introduction.....	3
II. Assembly of Dryer.....	4
III. Safety Procedures.....	5
IV. Assembly	
Step 1: Attaching the Infeed.....	6
Step 2: Attaching the Outfeed.....	7
Step 3: Installing the Belt.....	8
Belt Routing Diagram.....	10
Step 4: Connecting to the Belt Drive Motor.....	11
VI. Controls.....	12
VII. Recirculation System.....	14
VIII. Ventilation.....	15
IX. Maintenance.....	16
X. Belt Extension.....	17
XI. Wiring Diagram.....	22
XII. Limited Warranty.....	25

Introduction



	PD3009-3	PD3009-4	PD5409-3	PD5409-4
Belt Width	30" (76cm)	30" (76cm)	54" (137cm)	54" (137cm)
Heater Width	24" (61cm)	24" (61cm)	48" (122cm)	48" (122cm)
Heat Chamber	54" (137cm)	54" (137cm)	54" (137cm)	54" (137cm)
Overall Width	48" (122cm)	48" (122cm)	72" (183cm)	72" (183cm)
Overall Length	107" (272cm)	107" (272cm)	107" (272cm)	107" (272cm)
Radiant Panels	3	4	3	4
Est. Production	400+ Plastisol 150+ WB /DC	450+ Plastisol 200+ WB /DC	900+ Plastisol 300+ WB /DC	950+ Plastisol 400+ WB /DC
Electrical	1 Ph/240V/47A 3 Ph/240V/31A 3 Ph/208V/27A	1 Ph/240V/62A 3 Ph/240V/40A 3 Ph/208V/35A	3 Ph/240V/58A 3 Ph/208V/50A	3 Ph/240V/76A 3 Ph/208V/65A

Congratulations on your purchase of the Powerhouse Series II Conveyor Dryer.

Check the crate for damages. DO NOT accept the crate if there are any damages caused by improper handling during shipping. Immediately report any damages to the carrier and contact Workhorse Products at, 800-778-8779.

Be sure to inspect the crate contents IMMEDIATELY, while the carrier is still present. Even though our packaging has been designed to handle normal shipping conditions, we cannot foresee damages caused by the carrier. We will not be responsible for damages that occur during transportation.

If there are damages immediately notify the driver, file a claim with the carrier and call Workhorse Products.

The Importance of the Owner's Manual:

The purpose of the Owner's Manual is to familiarize you with the parts and operations of the Powerhouse Series II Conveyor Dryer. There are step-by-step instructions to assemble the product, explanations of the product's key features, and additional information that will help with the maintenance of the product.

Assembly of Dryer

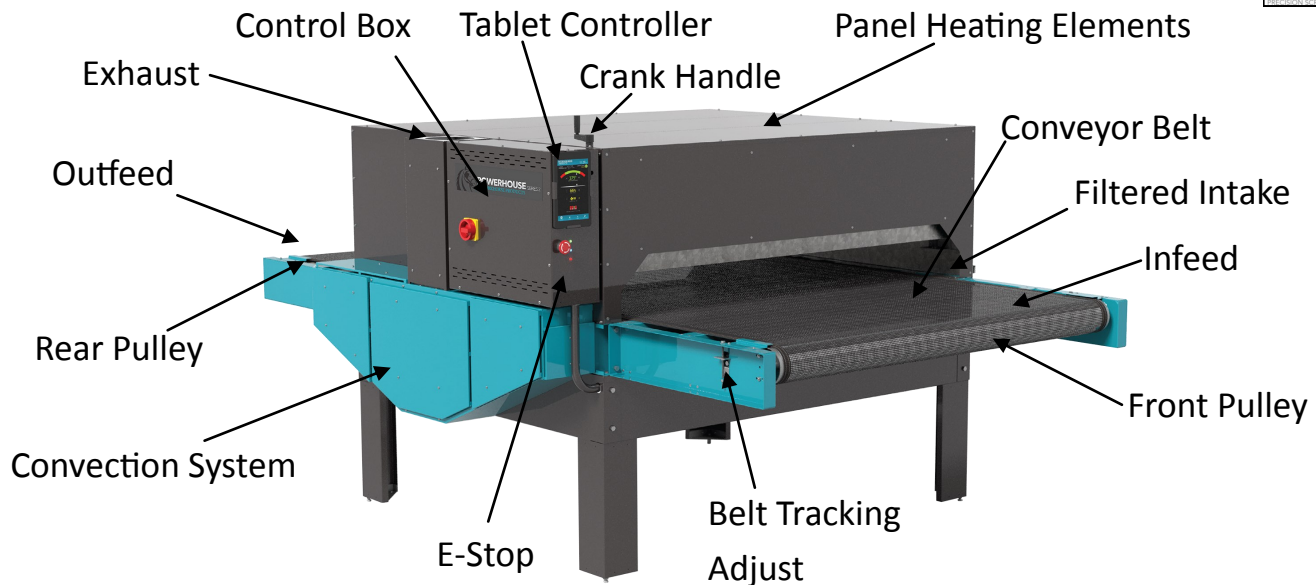

Panel Heating Elements

Underneath the top panel there are three infrared radiant panel heating elements that are controlled by the tablet controller. They can cure plastisol, water-based ink, and any evaporative cured ink. They are capable of heating up and cooling down within seconds.

Control Box

Most of the machine's electrical components are located within the control box. This box is easily accessible for any necessary maintenance.

Crank Handle

Used to raise and lower the heating elements to adjust heat distance to the garment. To raise the element turn the crank handle clockwise. Turn the crank handle counterclockwise to lower the element.

Exhaust

The exhaust is used to release heat. Use the push pin handle next to the exhaust to control the amount of heat released.

Filtered Intake

Filters the incoming air and needs to be cleaned whenever it becomes filled.

Conveyor Belt

The conveyor belt is created of Teflon coated fiber glass and is placed on a self-aligning belt tracking system. The belt is designed to withstand heat, but be sure the belt is always moving when the Powerhouse II is operating above 300 degrees.

Belt Tracking Adjust

Used for tracking the belt and keeping the belt on the pulley. If the belt moves to the side, use the belt tracking adjust to center it.

Pulley

The pulleys are created for precise rolling at an even center.

Tablet Controller

The tablet controller is the main control system for the Powerhouse Series II. The tablet programs the temperature, belt speed, warm up, cool down, power consumption, create presets, access the owner's portal, and contacts Workhorse technical support if ever needed.

Convection System

A precisely designed air system to utilize and release heat within the dryer.

Infeed

Where the garments are placed to start the curing process.

Outfeed

Where the garments exit the curing process. They land on a cool down table and eventually run off the belt.

WARNING!

RISK OF ELECTRICAL SHOCK! Turn ALL power to unit OFF before service.

All service should be done by or under the supervision of a trained technician

1. For your safety, do not store or use gasoline or other flammable vapors and liquids in the vicinity (at least 3' (1 Meter)) of this or any other appliance.
 2. Vent lines to the outdoors must be installed by a qualified HVAC engineer on all air exhaust components equipped with a vent fitting.
 3. Proper grounding (a ground rod at the equipment footing), according to NEC requirements, must be provided for during electrical connection by a **QUALIFIED ELECTRICIAN**.
 4. Never alter the internal wiring of this machine.
 5. Never place any item other than the substrates to be cured or dried on this dryer's conveyor belt. Do not overload the belt.
 6. Do not let the conveyor belt track off the conveyor drive rollers.
 7. Keep all loose articles (including clothing, hair, jewelry, etc.) away from the conveyor belt.
 8. Never leave the machine unattended during operation.
 9. Do not perform maintenance on this machine until all power has been shut off at the dryer **AND** at the incoming power circuit breaker.
-

THIS ELECTRIC DRYER IS INTENDED SOLELY FOR THE PURPOSE OF CURING INK ON TEXTILE AND CUT GOODS. THIS DRYER IS NOT INTENDED FOR USE IN HEATING, CURING OR BAKING OF ANY OTHER MATERIALS.

THIS DRYER IS INTENDED FOR INDOOR USE ONLY



THE EXCLAMATION WITHIN AN EQUILATERAL TRIANGLE SYMBOL IS INTENDED TO ALERT THE USER OF IMPORTANT SAFETY PRECAUTIONS TO BE AWARE OF DURING OPERATION.

Step 1: Attaching the Infeed

Tools needed:

- 9/16" Socket Wrench
- 9/16" Wrench

Parts needed:

- Infeed Arm
- 4 x Hex Bolt (3/8-16 x 3/4")
- 4x Flanged Nuts (3/8-16")
- 4 x Flat Washers

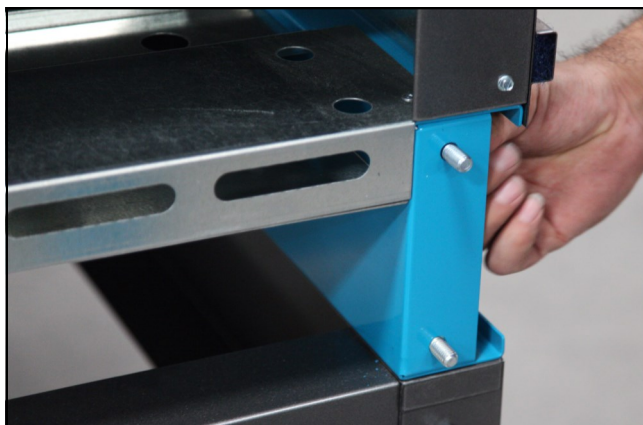

1. The infeed arm (the arm without the cooling table), must be attached to the side with the tablet. Insert a hex bolt and washer into the four holes where the arm will connect. Make sure the hex bolt is facing out and exposed.

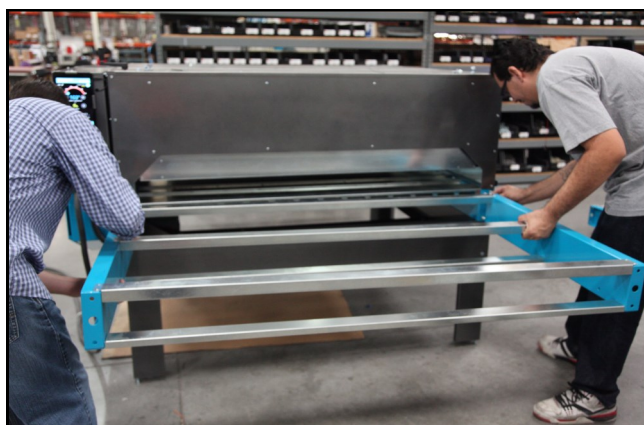

2. With another person and two flanged nuts in hand, lift up the infeed and insert it into the four exposed hex bolts.

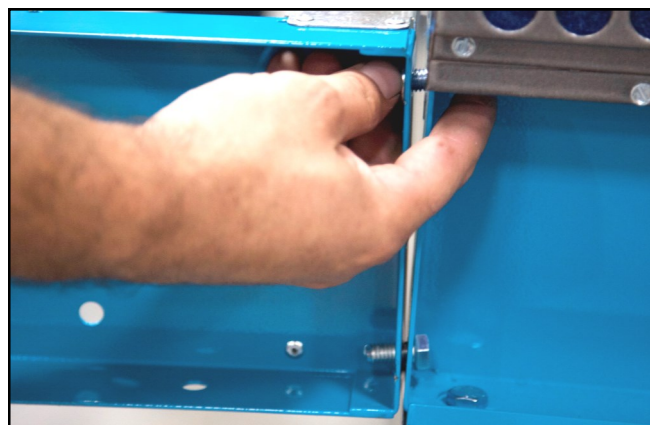

3. While holding the infeed, hand tighten the nut to the top hex bolt first. **The top hex bolt needs to be done first because it relieves weight from the top.** Hand tighten a second nut to the bottom hex bolt. Be sure to do step three on both sides simultaneously.



4. Using the 9/16" wrench on the top of the bolt and the 9/16" socket wrench on the nut, tighten all four hex bolts.

Step 2: Attaching the Outfeed

Tools needed:

- 9/16" Socket Wrench
- 9/16" Wrench

Parts needed:

- Infeed Arm
- 4 x Hex Bolt (3/8-16 x 3/4")
- 4x Flanged Nuts (3/8-16")
- 4 x Flat Washers



1. The outfeed arm (the arm with the cooling table), must be attached to the side opposite of the tablet. Insert a hex bolt and washer into the four holes where the arm will connect. Make sure the hex bolt is facing out and exposed.

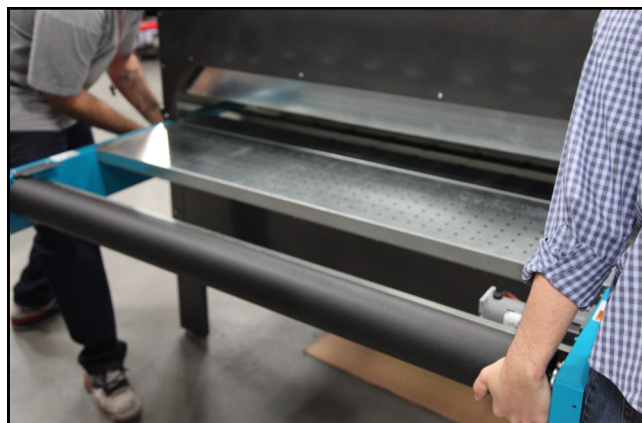

2. With another person and two flanged nuts in hand, lift up the outfeed and insert it into the four exposed hex bolts.

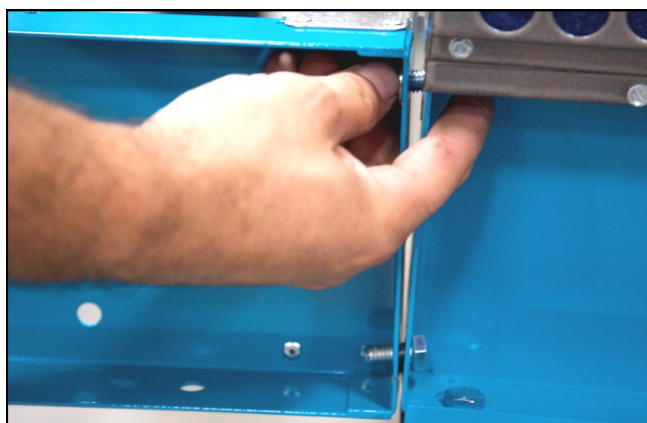

3. While holding the outfeed, hand tighten the nut to the top hex bolt first. Hand tighten a second nut to the bottom hex bolt. Be sure to do step three on both sides simultaneously.



4. Using the 9/16" wrench on the top of the bolt and the 9/16" socket wrench on the nut, tighten all four hex bolts.

Step 3: Installing and Tracking the Belt

Parts needed:

- Belt
- Threading Pin

1. When first installing the belt, on the infeed side of the dryer, remove the top nut and bolt holding the infeed roller in place. Once removed, loosen the bottom nut, but keep in place. After loosening the bottom nut, roll the infeed roller forward so there is less tension on the belt when installing the pin.

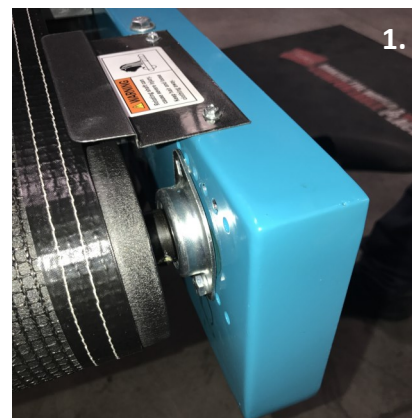
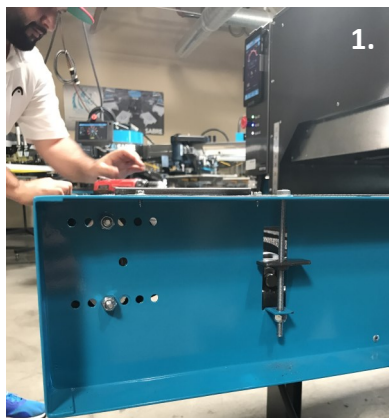

2. Feed the belt from the outfeed side of the dryer, through the top of the chamber. Pull the belt through the infeed side and over the infeed roller.

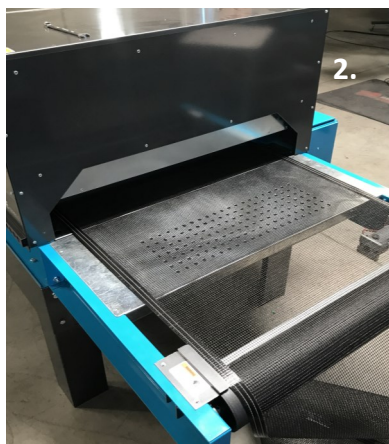

3. Run the belt under the infeed roller and then above the tension roller and above the lower support. Then feed the belt through the lower portion of the chamber and out the outfeed side of the dryer.

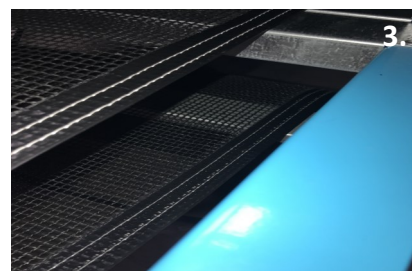
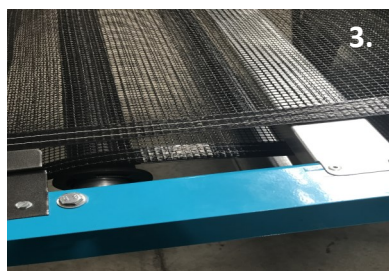

4. On the tablet side of the dryer, line up the yellow marks on the teeth. Push the pin through the teeth making sure to have the same amount of extra pin on both sides.

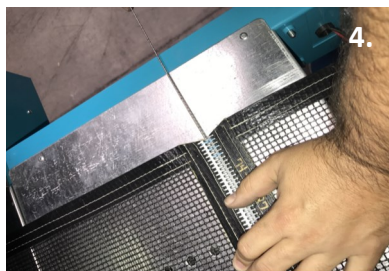

Step 3: Installing and Tracking the Belt

Parts needed:

- Belt
- Threading Pin

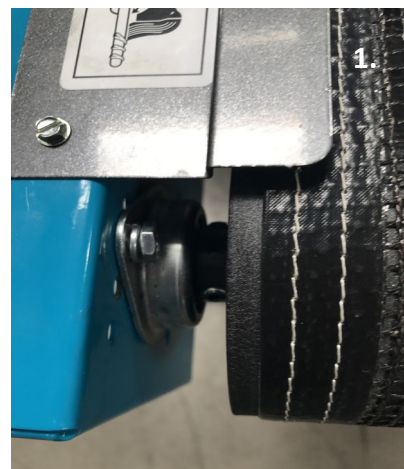
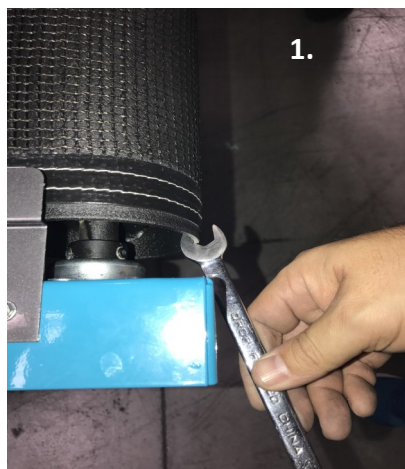

1. Once the belt is pinned together, you will need to reinstall the nuts and bolts for the infeed roller. Move the roller bearing back into place so that the bottom bolt and top bolt are aligned. The bolt will go into the bearing from the roller side of the arm and the nut will tighten down on the outside of the arm.

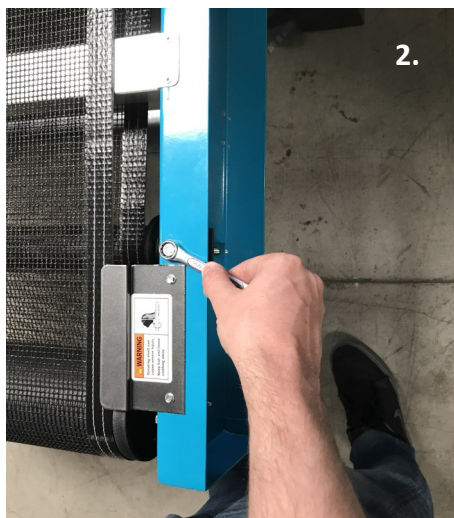

2. After the infeed roller is bolted back into place, turn the dryer on with a belt speed of 100% and let run for 5 minutes. You will be able to see if the belt is tracking correctly. If the belt is not tracking properly, use the bolts for the tension roller on the infeed side of the dryer. If the belt is moving left, use the right bolt and make a 1/4 turn right and watch the adjustment. Continue the process until the belt has tracked correctly. Make the same adjustments on the other side of the dryer if the belt is moving to the right. When completed, the belt should be tracking underneath both tracking plates without moving to one side or the other.

Belt Routing Diagram

- NOTES:
1. THE DRYER BELT IS TESTED AT THE FACTORY FOR TRACKING AND TENSION. TOLERANCES FOR THE LENGTH OF BELTS DEPENDS ON MANUFACTURER.
 2. THE BELT IS REMOVED AT THE FACTORY BY FULLY LOWERING THE TRACKING ROLLER AND THEN PULLING THE PIN WIRE OUT OF THE ALLIGATOR LADE ON THE BELT.
 3. IF THE TRACKING ROLLER IS NOT ALREADY LOWERED AS FAR DOWN AS IT WILL GO, LOWER IT AS FAR DOWN AS IT WILL GO BEFORE INSTALLING THE BELT.
 4. ROUTE THE BELT PER THE DIAGRAM BELOW.
 5. BELT CAN BE INSTALLED EITHER DIRECTION.
 6. IF BELT IS TO TIGHT TO LACE, THEN REMOVE THE TOP INFEED BEARING BOLTS ON BOTH SIDES AND LET THE INFEED ROLLER SWING FORWARD. REINSTALL THE BOLTS IN THEIR ORIGINAL POSITIONS AFTER THE BELT IS LACED.
 7. RAISE THE TRACKING ROLLER TO PUT TENSION ON THE DRYER BELT. MEASURE THE POSITION OF EACH SIDE OF THE TRACKING ROLLER TO MAKE SURE YOU ARE STARTING WITH EVEN TENSION ON BOTH SIDES.
 8. THE BELT ONLY NEEDS TO BE TIGHT ENOUGH TO MOVE SHIRTS THROUGH OVEN UNDER LOAD.
 9. RAISE THE LEFT SIDE OF THE TRACKING ROLLER TO MOVE THE BELT RIGHT AND RAISE THE RIGHT TO MOVE IT LEFT.

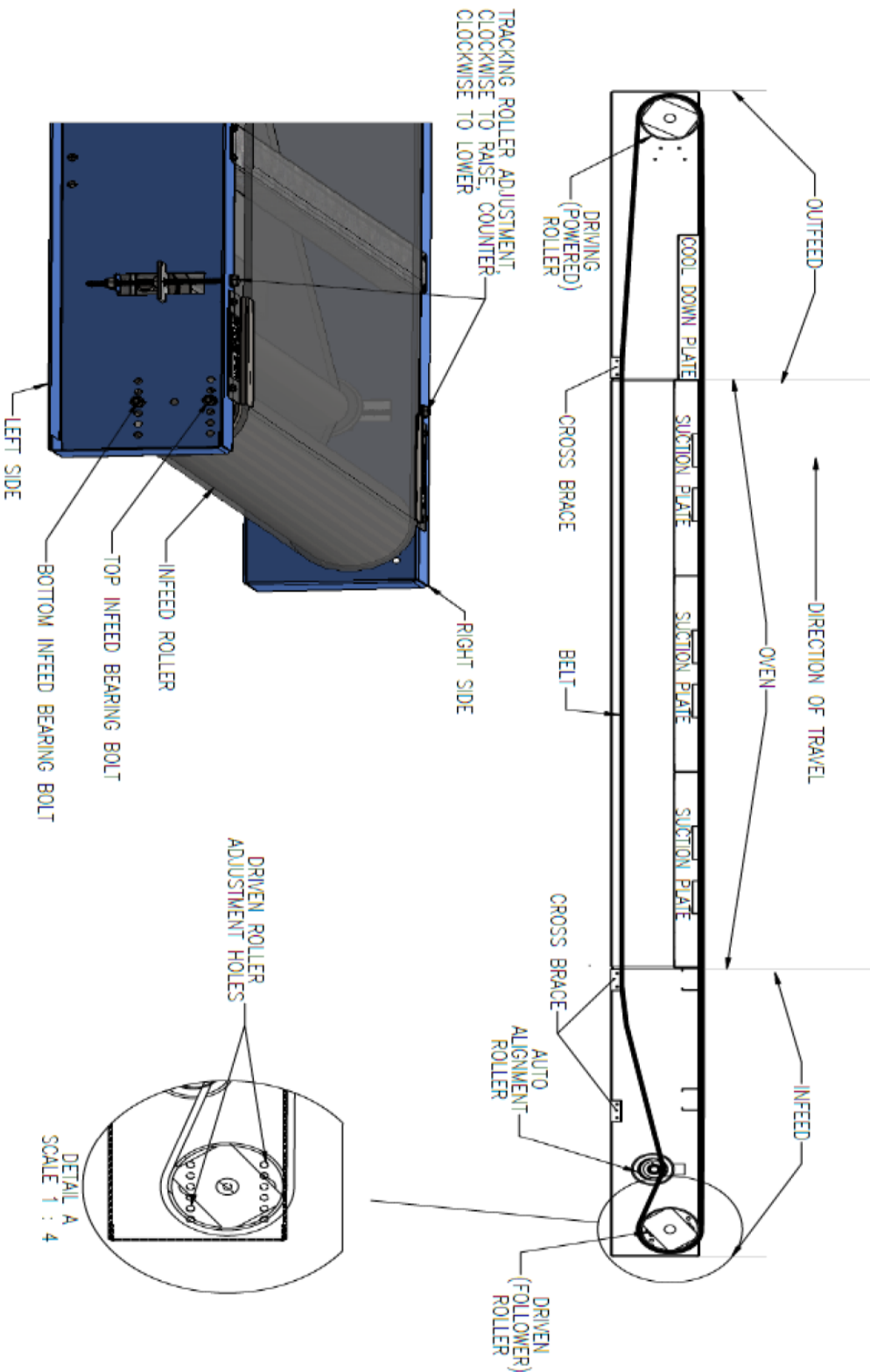

Step 4: Connecting to the Belt Drive Motor



1. On the outfeed side, take the belt drive motor cable and feed it through the hole located at the edge of the arm.

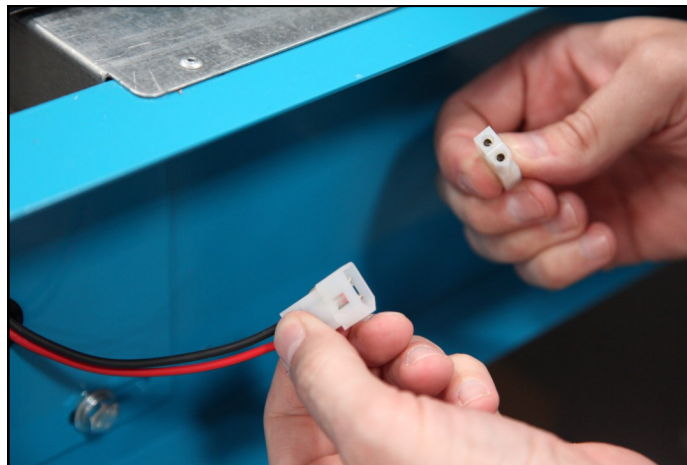

2. Connect the belt drive motor cable to the motor cable. Congratulations! The Powerhouse Series II Dryer is now fully assembled!



The size and specifications of the electrical connections made during installation **MUST BE DETERMINED BY A LICENSED ELECTRICIAN. FOLLOW ALL LOCAL BUILDING AND PLANNING CODES.** Failure to do so may result in damage to the unit, building, or cause serious injury.

Before any electrical connections are made verify all safety precautions have been taken to ensure the safety of all shop personnel. The dedicated breaker providing power to the dryer **MUST BE OFF, AND USE OF A SERVICE LOCKOUT TAG IS REQUIRED.** This will prevent anyone from turning on the power as the connections are being made. After all safety precautions have been taken the electrical connections can be made. All electrical connections must be made by a licensed electrician. Refer to factory specifications for proper installation.

Controls



Before turning the dryer on make sure that the belt is empty.

Touch the idle screen so it opens up into the main menu:

- A. **Set Temperature** - The temperature the dryer is set to achieve.
- B. **Current Temperature** - The temperature the dryer is currently at.
- C. **Belt Speed** - The speed of the belt.
- D. **Heating Elements** - Indicates the status of the heating element. Whether if the heating element is receiving power or when it is actually on.
- E. **Current Mode** - The mode the dryer is on. For example, if set to a preset the preset's name would be the current mode. Manual mode means that the dryer is set to manual settings without a preset.
- F. **Operating Costs** - Based on temperature, airflow, and exhaust settings the dryer is able to calculate price per hour for every job.
- G. **Power** - Turn the dryer on/off.
- H. **Logs** - Specifics and logistics for each job the dryer executes.
- I. **Help** - Opens the help options menu.
- J. **Settings** - Opens the settings menu.

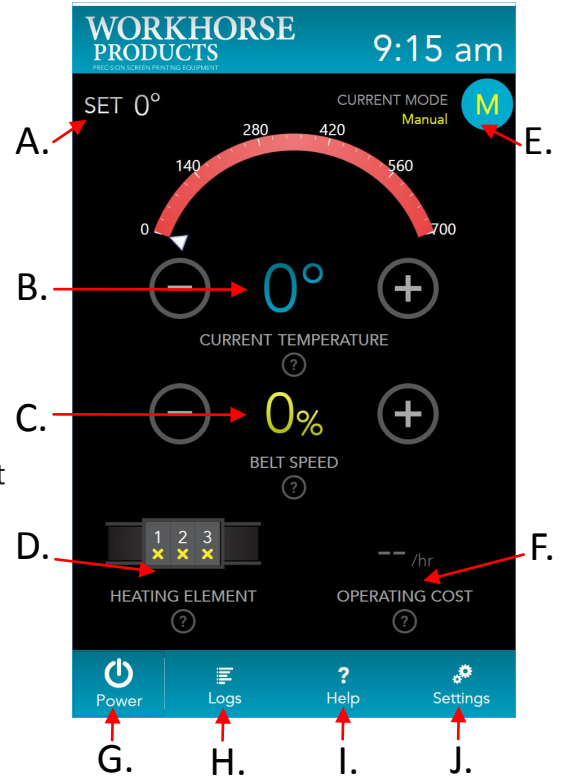

Help Menu:

- K. **Check for Updates** - Checks for system updates (Wi-Fi Connection required).
- L. **Register Machine** - Register the machine online.
- M. **Change Time** - Adjusts the date and time on the machine.
- N. **Configure Wi-Fi** - Opens the Wi-Fi configuration menu where the machine can connect to Wi-Fi. When connected to the Wi-Fi the machine can receive updates, communicate with the cloud, and allow for remote troubleshooting.
- O. **Restart Tablet** - Will restart the machine if needed. This button should not be used on a regular basis.
- P. **Support Connect** - Directly connect with Workhorse Products support.
- Q. **Close** - Will close the sub-menu and return to the main menu.

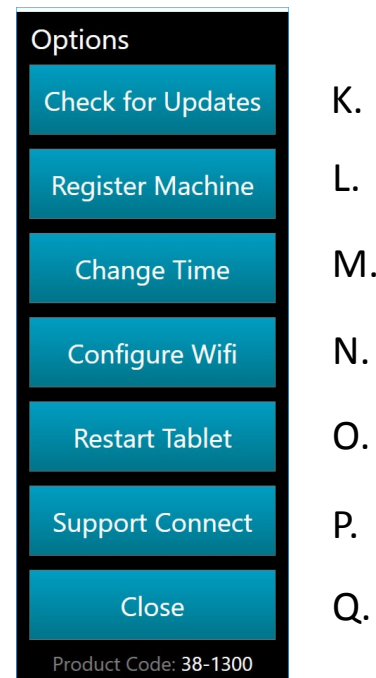

Controls (Continued)



Settings Menu:

- A. **Presets** - Set custom presets for reoccurring jobs.
- B. **Preset Name** - Name the custom preset, (Workhorse Products has programed generic custom presets into the dryer, but they are by no means presets that should be highly regarded).
- C. **Temperature** - The set temperature for that preset.
- D. **Belt Speed** - The set belt speed for that preset.
- E. **Kilowatt Cost** - Operating cost.
- F. **Inputs/Outputs, PID Values and Dryer Options** - This grey box is for Workhorse programming. Users are unable to access this box and have read only access.
- G. **Ok** - Click "Ok" to set the settings. By hitting "Ok" the settings will be saved and programmed for the job.
- H. **Cancel** - Click "Cancel" to not save and exit out of the settings. By hitting "Cancel" the settings will not be programmed for the job.

The screenshot shows the 'Settings' menu with the following fields and buttons:

- Preset 1 Settings:** Preset Name (Sweatshirts), Temp (605), Belt Speed (25)
- Preset 2 Settings:** Preset Name (Waterbased), Temp (500), Belt Speed (35)
- Preset 3 Settings:** Preset Name (Plastisol), Temp (695), Belt Speed (55)
- Kilowatt Cost:** 0.13
- Inputs/Outputs, PID Values, and Dryer Options (Grey Box):**
 - ESTOP: 4
 - HEATERS: 0
 - FAN: 1
 - MOTOR: 2
 - Heater 4: -1
 - Unlock button
 - PID Values: Curr Kp (16.16), Curr Ki (0.14), Curr Kd (480.10), Std Kp (16.16), Std Ki (0.14), Std Kd (480.10)
 - Dryer Options: Window (5000), HEAT ON (150), Agg Val (8), Output (0), Panel Size (Small)
- Buttons:** OK, Cancel

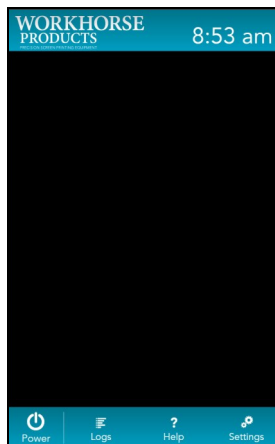

This what the Powerhouse Series II tablet looks like when it is in idle mode.

Recirculation System

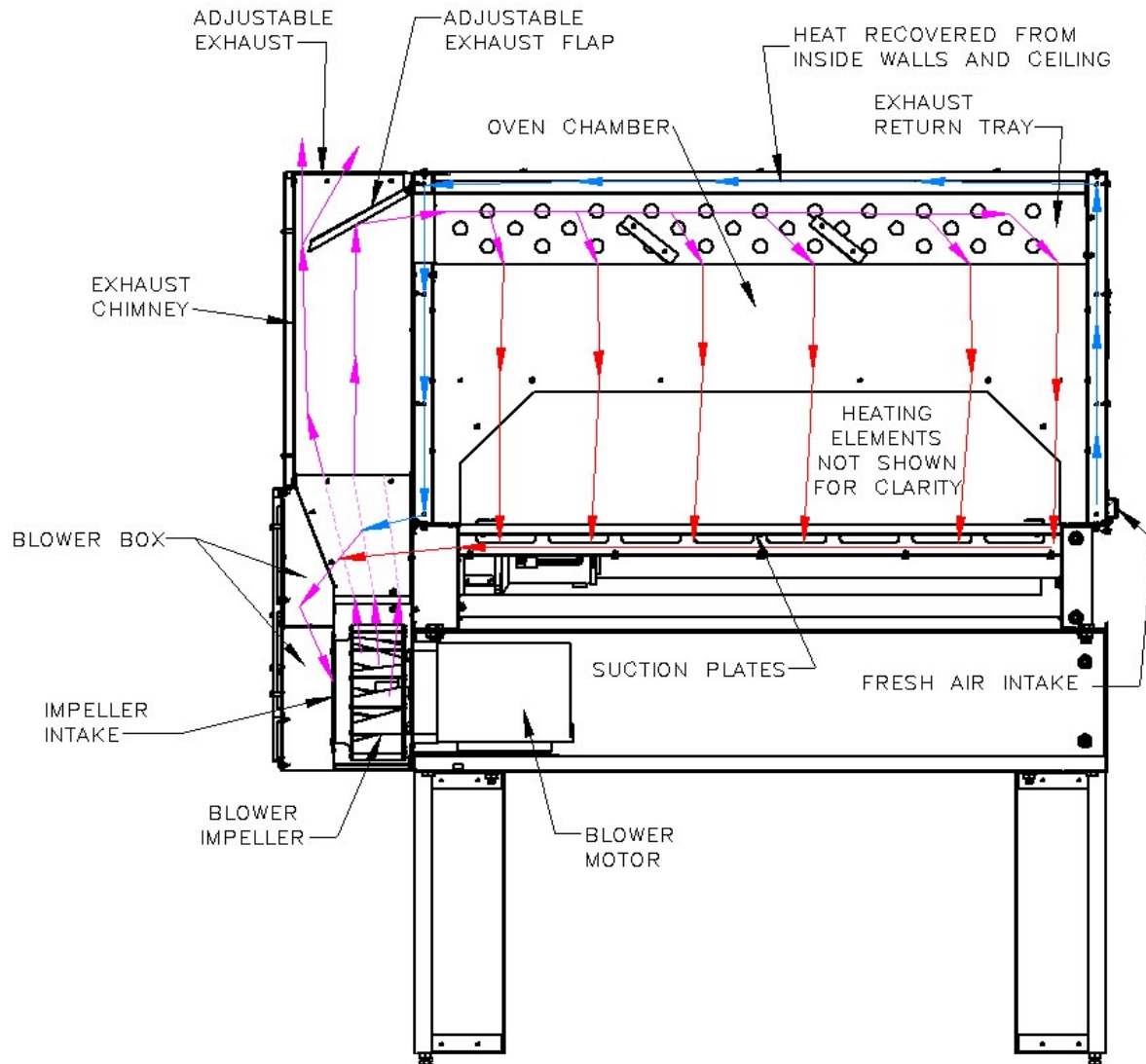

Powerhouse Series II Recirculation System:

1. The impeller pulls heated air in from the blower box and directs it up through the exhaust chimney.
2. The adjustable exhaust flap directs desired amount of heated air back into the oven chamber via the exhaust return tray. The remainder of the exhaust exits through the top of the chimney.
3. Heated air in the oven chamber is pulled down through the suction plates and into the blower box by the impeller.
4. Fresh air is pulled through chambers between the outer and inner walls and into the blower box. This recovers the otherwise wasted heat from the inside walls of the oven.
5. Oven air and heated fresh air are mixed in the blower box and pulled into the impeller for exhaust.

Ventilation



The ventilation system is capable of being adjusted to control the hot airflow. The hot airflow interacts with the heating panels and affects how the garments are cured. The two major settings are open and closed, everything in-between is a variation of either open or closed.



Ventilation Open:

When the ventilation is open more hot air is released, which means less hot air in the chamber. This type of airflow is normally used for water based and discharge inks. The ventilation system needs to be open because the evaporative chemicals from the garments need to be released.



Ventilation Closed:

When the ventilation is closed less hot air is released, which means more hot air in the chamber. The hot air in the chamber helps the dryer reach a specific temperature. More hot air also means that the panels run less, making it more cost effective. This is more like convection type heat and is typically used for standard plastisol inks.

The ventilation port is located next to the control box. This port can be connected to a standard 6" HVAC duct line vented to the outside of the building. For longer duct lines to the outside of the building; or if local building codes require roof top ventilation, inline duct boosters may be used.

It is recommended that the ventilation system duct line be professionally installed in compliance with all local building codes to ensure the safety of all shop personnel.

Filtration System:

General use of the dryer will cause lint and debris from garments and the area surrounding the Powerhouse II to collect inside the internal air chambers. The filter on the side of the dryer is designed to be easily accessed so the filter can be cleaned. Wash with a mild soap and water. Use air hose or allow to air dry. Filter should be completely dry before re-installing into the dryer.



Belt Tracking:

The self-tracking system is designed to keep the belt centered on the front and rear pulley. However, sometimes the belt may come off-center. To put the belt back on center use a 7/16" socket wrench on the bolt located on top of the dryer arm. This will tilt that side of the pulley up or down.

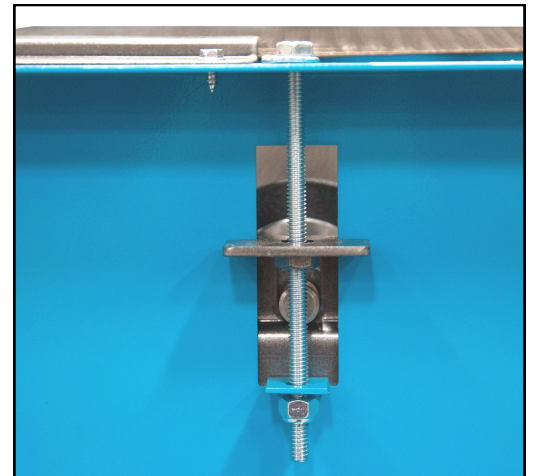

Gears and Chains:

Chains can loosen over time and should be inspected, adjusted and lubricated whenever necessary.

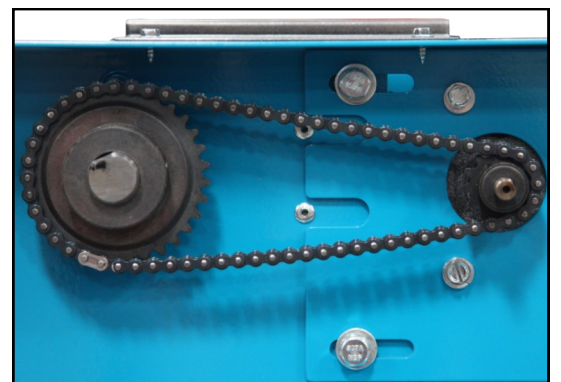

Workhorse Products recommends performing these routine maintenances every three to six months to maintain optimum performance of your dryer.

Belt Extension

- "CAUTION" LOCK OUT, TAG OUT ALL POWER TO DRYER.
- TURN BOLT ON ENDS OF BELT TENSIONING TO TAKE TENSION OFF CONVEYOR BELT. TO REMOVE THE CONVEYOR BELT (NOT SHOWN), PULL OUT THE PIN WIRE THAT HOLDS THE ZIPPERED ENDS OF THE BELT TOGETHER.
- DISCONNECT POWER CABLE FROM BELT DRIVE MOTOR. ROLL UP LOOSE CABLE, PLACE OUT OF WAY.
- UNBOLT AND REMOVE THE INFEED AND/OR THE OUTFEED ASSEMBLY(S) DEPENDING ON WHICH END(S) YOU ARE INSTALLING AN EXTENSION.

STEP 1: (IF YOU ARE INSTALLING EXTENSION(S) ON A DRYER THAT HAS NOT BEEN SET UP THEN SKIP STEP 1.) EXTENSIONS ARE SHOWN INSTALLED ON BOTH ENDS FOR CLARITY OF INSTRUCTIONS. OK TO INSTALL ON EITHER END WITHOUT INSTALLING ON THE OTHER.

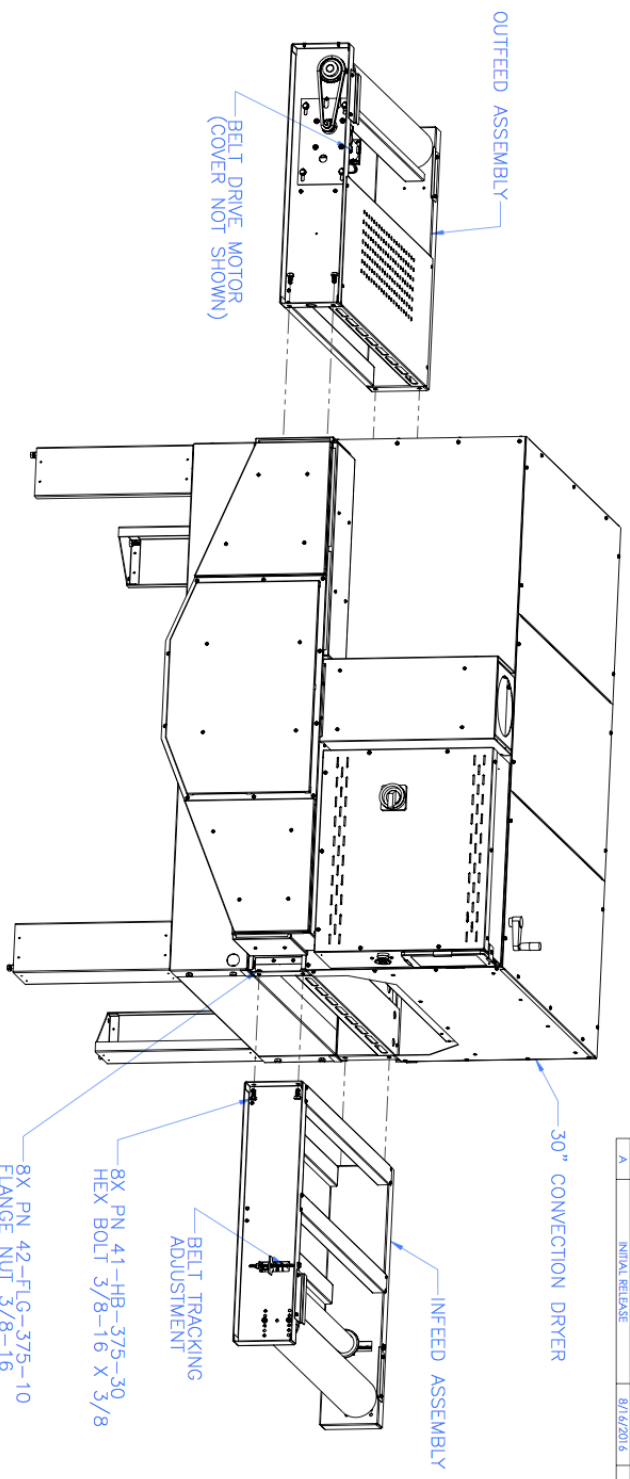

8X PN 42-FLG-375-10
 FLANGE NUT 3/8-16

8X PN 41-HB-375-30
 HEX BOLT 3/8-16 X 3/8

REV	DESCRIPTION	DATE	APPROVED
A	INITIAL RELEASE	8/16/2016	WEB

TOL.	APPROVALS	DATE
XXX ± .010	DM: WEB	08/16/16
ANGLES ± .1°	CHK: /	/
NEW ASSEMBLY	APPR: /	/
	FILE: /	/
WAT: SEF		
	BOM	
TNI: NONE		

The Bergmann Group
 Phoenix, Arizona 85040

INSTALLATION OF 18" AND 36" EXTENSIONS, CONV DRYER

SIZE PART NO. **F-PD-IFOF-EXT** REV **A**

SCALE: 1:10 08/16/2016 SHEET: 1 OF 5

Belt Extension (Continued)

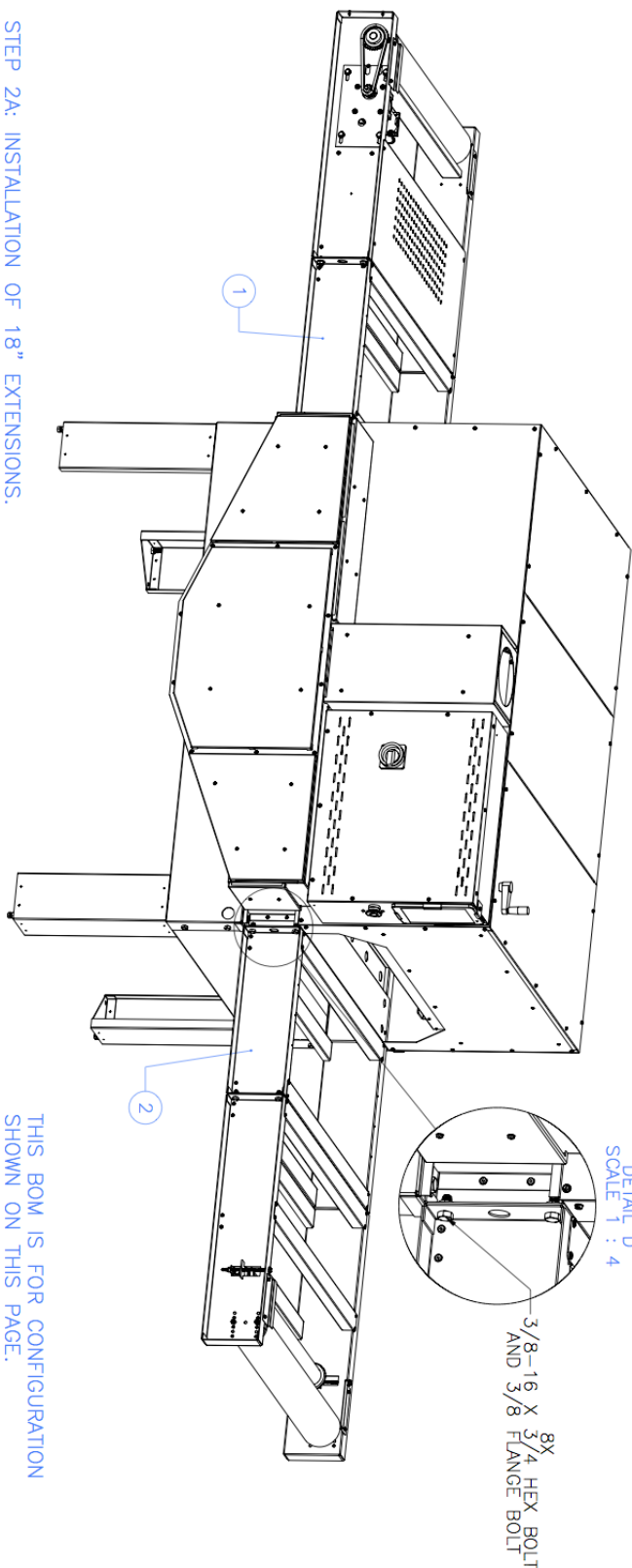

THIS BOM IS FOR CONFIGURATION SHOWN ON THIS PAGE.

- STEP 2A: INSTALLATION OF 18" EXTENSIONS.
- USE THE 3/8-16 X 3/4" HEX BOLTS AND THE 3/8-16 FLANGE NUTS PROVIDED TO BOLT EXTENSIONS ONTO THE INFEED AND OUTFEED ENDS AS SHOWN.
 - USE THE ORIGINAL NUTS AND BOLTS TO ATTACH THE INFEED AND OUTFEED SECTIONS.

- ROUTER AND RECONNECT THE POWER CABLE TO THE BELT MOTOR.
- REINSTALL THE CONVEYOR BELT ALONG WITH ANY BELT EXTENSION SECTIONS PROVIDED. EACH 18" EXTENSION WILL HAVE A 36" BELT EXTENSION.
- RESTORE POWER TO DRYER AND TEST OPERATION.

ITEM NO.	QTY	PART NUMBER	Description
1	1	PD-IFOE-EXT-3009	INFEED OUTFEED 18" EXT PD-3009 SET
2	1	PD-IF-EXT-3009	INFEED 18" EXTENSION PD-3009 SET

TOL:	XX ±.010	APPROVALS:	DATE:
ANGLES:	XX ±.1°	OWN: WEB	08/16/18
NEXT ASSEMBLY:		CHK:	/ /
WAT:		APPR:	/ /
FNE:		FILE:	/ /
		SEE BOM	
		NONE	

The Bergmann Group
 Phoenix, Arizona 85040

INSTALLATION OF 18" AND 36" EXTENSIONS, CONV DRYER

SIZE: B
 PART NO: F-PD-IFOE-EXT
 SCALE: 1:10
 08/16/2018
 SHEET: 2 OF 5

Belt Extension (Continued)



NOTE REVERSE DIRECTION OF BOLT TO PREVENT CONTACT WITH BELT

3/8-16 X 3/4 HEX BOLT AND 3/8 FLANGE BOLT

5

DETAIL A SCALE 1 : 2

3/8-16 X 3/4 HEX BOLT AND 3/8 FLANGE BOLT

5

DETAIL B SCALE 1 : 4

3/8-16 X 3/4 HEX BOLT AND 3/8 FLANGE BOLT

5

DETAIL C SCALE 1 : 4

LEVELING BOLTS ARE USED IF ALSO USED ON DRYER

INFEED ASSEMBLY

5

STEP 2B: INSTALLATION OF 36" EXTENSIONS.

a. USE THE 3/8-16 X 3/4" HEX BOLTS AND THE 3/8-16 FLANGE NUTS PROVIDED TO BOLT EXTENSIONS ONTO THE INFEED AND OUTFEED ENDS AS SHOWN.

b. USE THE ORIGINAL NUTS AND BOLTS TO ATTACH THE INFEED AND OUTFEED SECTIONS. ATTACH THE LEGS TO THE ENDS OF THE EXTENSIONS AND THE CROSS SUPPORTS TO THE LEGS AS SHOWN.

c. REROUTE AND RECONNECT THE POWER CABLE TO THE BELT MOTOR.

d. REINSTALL THE CONVEYOR BELT ALONG WITH ANY BELT EXTENSION SECTIONS PROVIDED. EACH 36" EXTENSION WILL HAVE A 72" BELT EXTENSION.

e. RESTORE POWER TO DRYER AND TEST OPERATION.

ITEM NO.	QTY	PART NUMBER	Description
5	2	PD-IF-EXT-3009-36	INFEED 36" EXTENSION, PD-3009-36

TOL:	XX ± .010	DATE	08/16/16
ANGLES ± .1"	XXX ± .005	CHK:	/ /
NEXT ASSEMBLY	CHK -	FILE	VELE
MAT:	SEE BOM	REV	A
FIN:	NONE	SCALE:	1:12

The Bergmann Group
Phoenix, Arizona 85040

INSTALLATION OF 18" AND 36" EXTENSIONS, CONV DRYER

SIZE PART NO. **B** F-PD-IFOF-EXT

SCALE: 1:12 108/16/2016 SHEET: 3 OF 5

THIS BOM IS FOR 2X 36" EXTENSION WITH LEGS FOR THE 3009 CONV DRYER. ASSEMBLY SA-1244. CONVEYOR BELT AND BELT EXTENSIONS NOT SHOWN

Belt Extension (Continued)

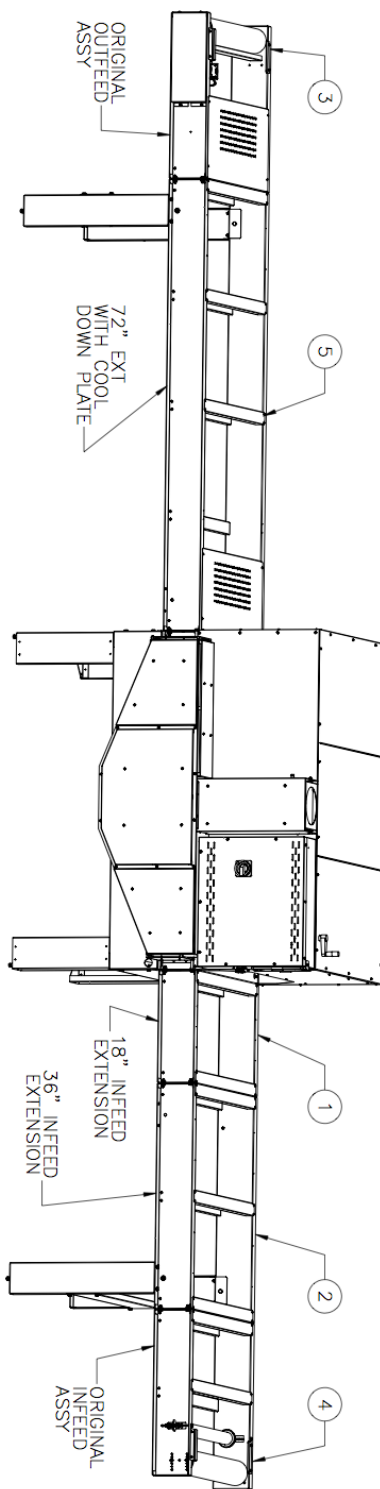

- STEP 2C: INSTALLATION**
- ASSEMBLY OF LEGS TO EXTENSIONS SAME AS PREVIOUS PAGE.
 - ALL 36" AND 72" EXTENSIONS COME WITH 2X LEGS AND 1X LEG SUPPORT.
 - NORMALLY MOUNT NO MORE THEN ONE 18" EXTENSION PER SIDE. MOUNTED ON DRYER.
 - DO NOT MOUNT 18" EXTENSION PRIOR TO A 72" EXTENSION WITHOUT ADDING A SECOND SET OF LEGS TO 72" EXTENSION.
 - 18" EXTENSIONS DO NOT COME WITH LEGS.
 - ALL OUTFEED EXTENSIONS COME WITH BELT MOTOR EXTENSION CABLES.
 - REROUTE AND RECONNECT THE BELT MOTOR CABLE AND BELT MOTOR CABLE EXTENSIONS TO THE BELT MOTOR.
 - REINSTALL THE CONVEYOR BELT ALONG WITH ANY BELT EXTENSION SECTIONS PROVIDED. EACH 36" EXTENSION WILL HAVE A 72" BELT EXTENSION. 18" EXTENSIONS WILL HAVE A 36" BELT EXTENSION.
 - RESTORE POWER TO DRYER AND TEST OPERATION.

THIS BOM IS FOR CONFIGURATION SHOWN ON THIS PAGE.

ITEM NO.	QTY	PART NUMBER	DESCRIPTION
1	1	PD-IF-EXT-3009	INFEED 18" EXTENSION PD-3009 SET
2	1	PD-IF-EXT-3009-36	INFEED 36" EXTENSION, PD-3009-36
3	1	SA-1207	OUTFEED ASSY, 24" LG, 30" CONV DRYER
4	1	SA-1208	INFEED ASSY, 24" LG, 30" CONV DRYER
5	1	PD-OF-EXT-3009-72	OUTFEED EXTENSION, 72" LG FOR 30" DRYER

TOL: .XX ± .010	OWN: WES	DATE: 11/20/16	The Bergmann Group	
XXX ± .005	ANGLES: ± 1°	CHK: -	PHOENIX, ARIZONA	85040
NEXT ASSEMBLY:	APPR: -	FILE: -	INSTALLATION OF 18" AND 36" EXTENSIONS, CONV DRYER	
VAT: -	SEE BOM	SCALE: 1:12	11/4/2016	SHEET: 4 OF 5

Belt Extension (Continued)

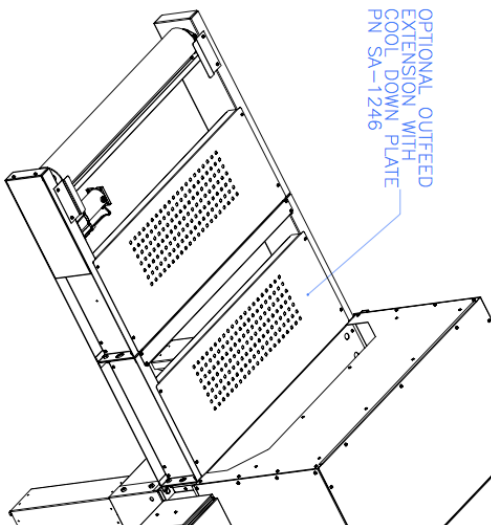

STEP 3: OPTIONS AND BELT ADJUSTMENTS.

- WHEN THE OUTFEED WITH COOL DOWN PLATE OPTION IS INSTALLED THE ORIGINAL COOL DOWN PLATE ON THE OUTFEED REMAINS IN PLACE.
- NOTE CONVEYOR BELT ROUTING WHEN INSTALLING THE CONVEYOR BELT. IF BELT ENDS DO NOT REACH EACH OTHER THEN LOWER THE BELT TRACKING ROLLER BY TURNING THE TENSION ADJUSTMENT BOLTS.
- ADJUST TENSION ON CONVEYOR BELT UNTIL TRACKING ROLLER STARTS TO CENTER THE BELT. INCREASE TENSION ON THE LEFT SIDE TO MOVE THE BELT TO THE RIGHT AND ON THE RIGHT TO MOVE IT TO THE LEFT.
- TRIM PIN WIRE(S) USED TO CONNECT ENDS OF BELT TO KEEP IT FROM CATCHING ON DRYER. (NOTE: LEAVE ENOUGH WIRE SHOWING TO ENABLE YOU TO REMOVE IT AS NEEDED.)
- IF BELT HAS PROBLEMS TRACKING, CHECK THAT DRYER AND EXTENSIONS ARE LEVEL. IF LEVELING BOLTS ARE NOT BEING USED THEN SHIM UNDER DRYER AND EXTENSION LEGS AS NEEDED.

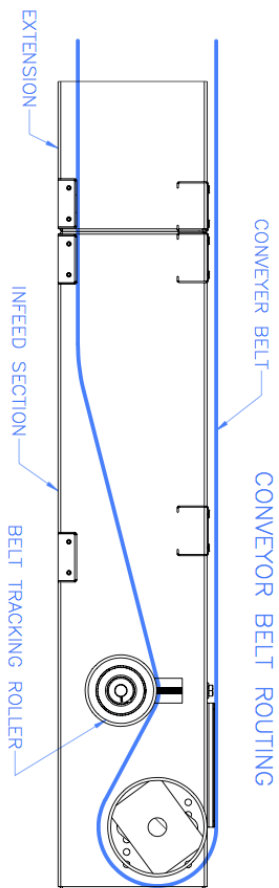

BELT TRACKING TENSION ADJUSTMENT

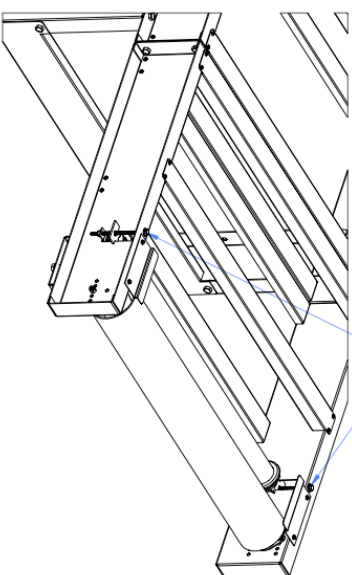

TOL	XXX ± .010	APPROVALS	DATE
XXX ± .005	OWN. WEB	REL/17/16	
ANGLES ± 1°	CHK	/ /	
NEXT ASSEMBLY	APPR	/ /	
MAT	SEE BOM	TITLE	VAL
FIN	NONE		
The Bergmann Group Phoenix, Arizona 85040			
INSTALLATION OF 18" AND 36" EXTENSIONS, CONV DRYER			
SIZE	PART NO.	REV	
B	F-PD-IFOF-EXT	A	
SCALE: 1:12	08/17/2016	SHEET: 5 OF 5	

Wiring Schematic

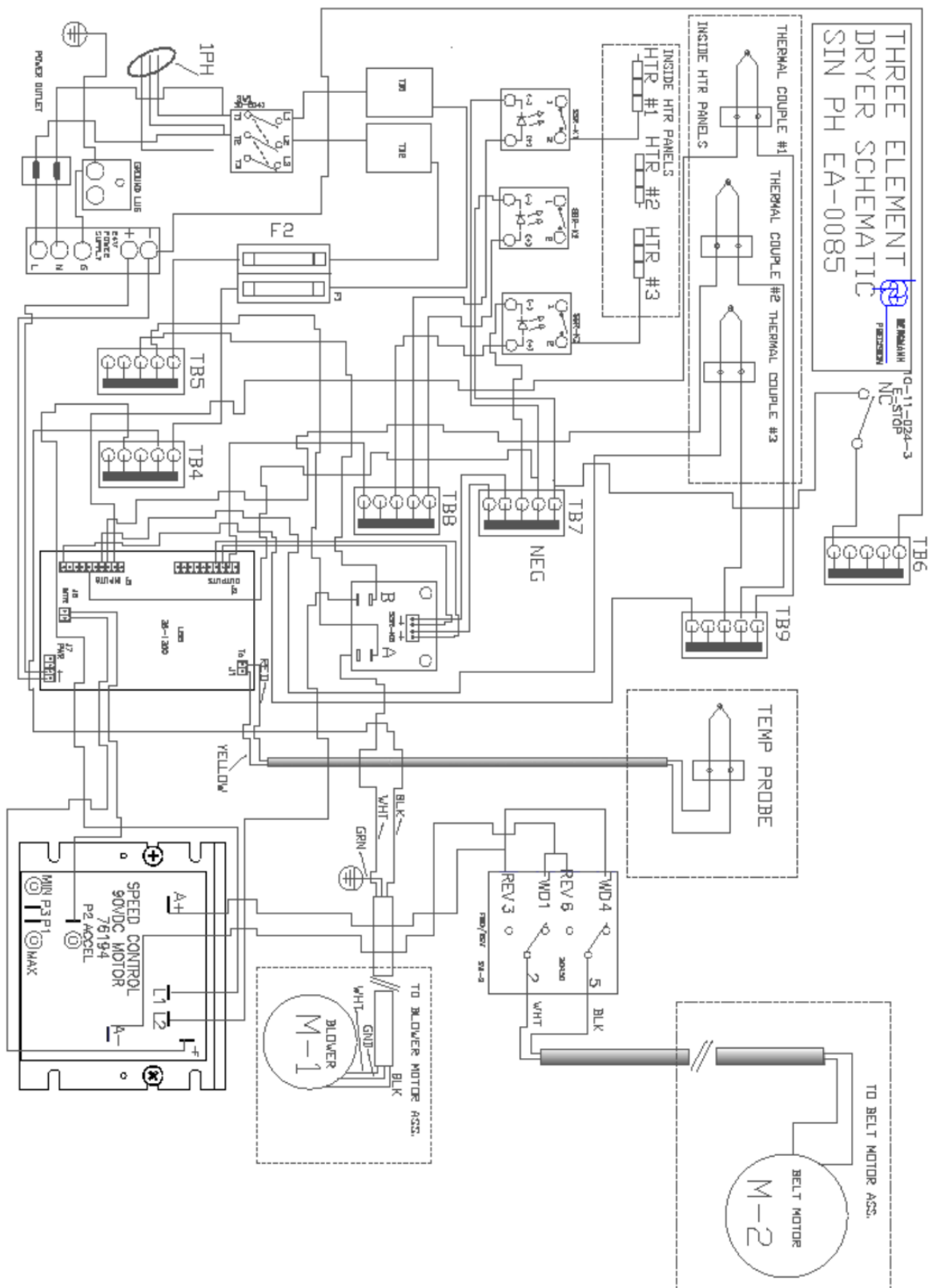

Wiring Schematic

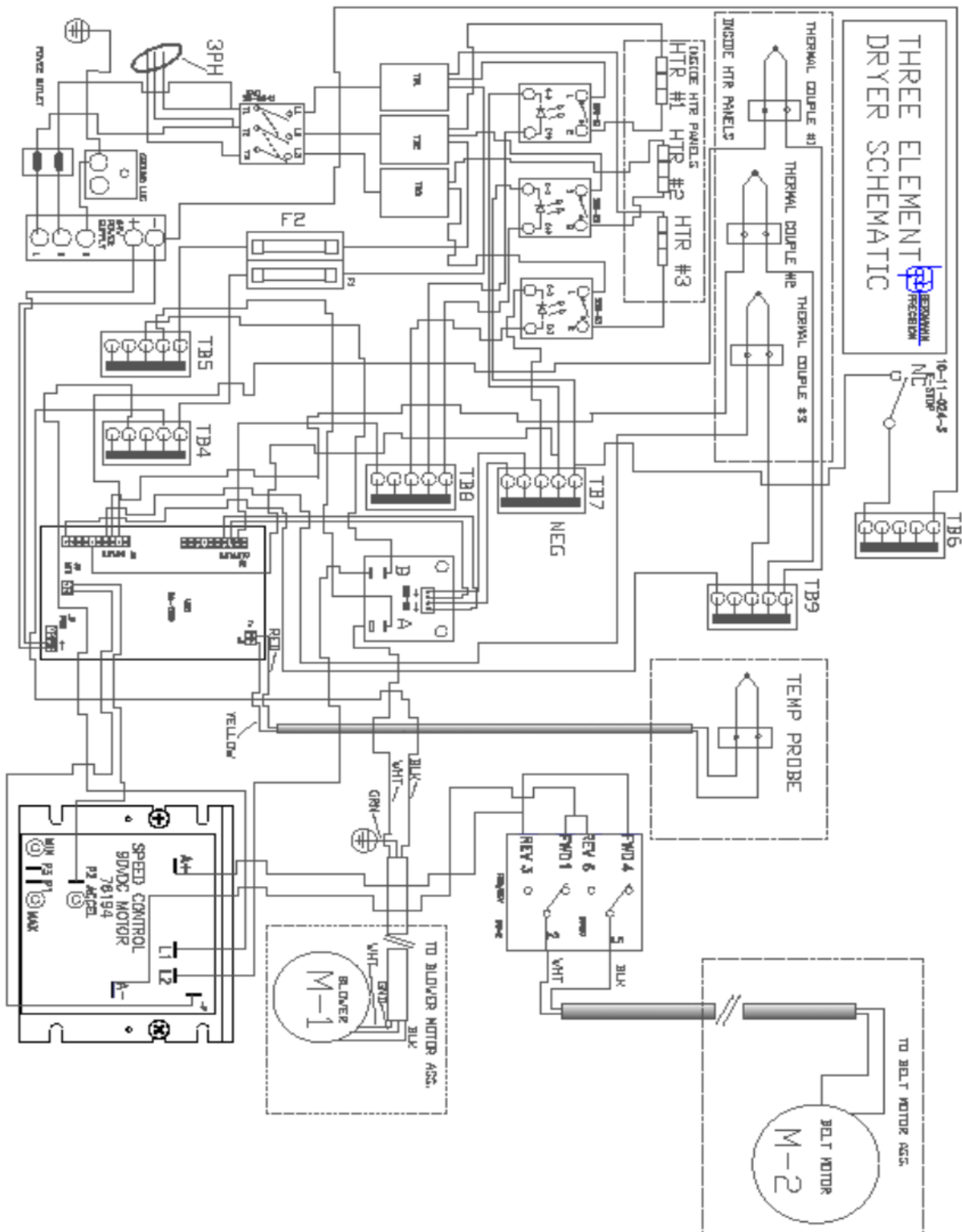

Wiring Schematic



PD3009-41 240V=40A 208V=35A
 PD5409-41 240V=75A 208V=65A
 * (Some units dual elements wired parallel)
FOUR ELEMENT DRYER SCHEMATIC
 3PH
REVISED 2016

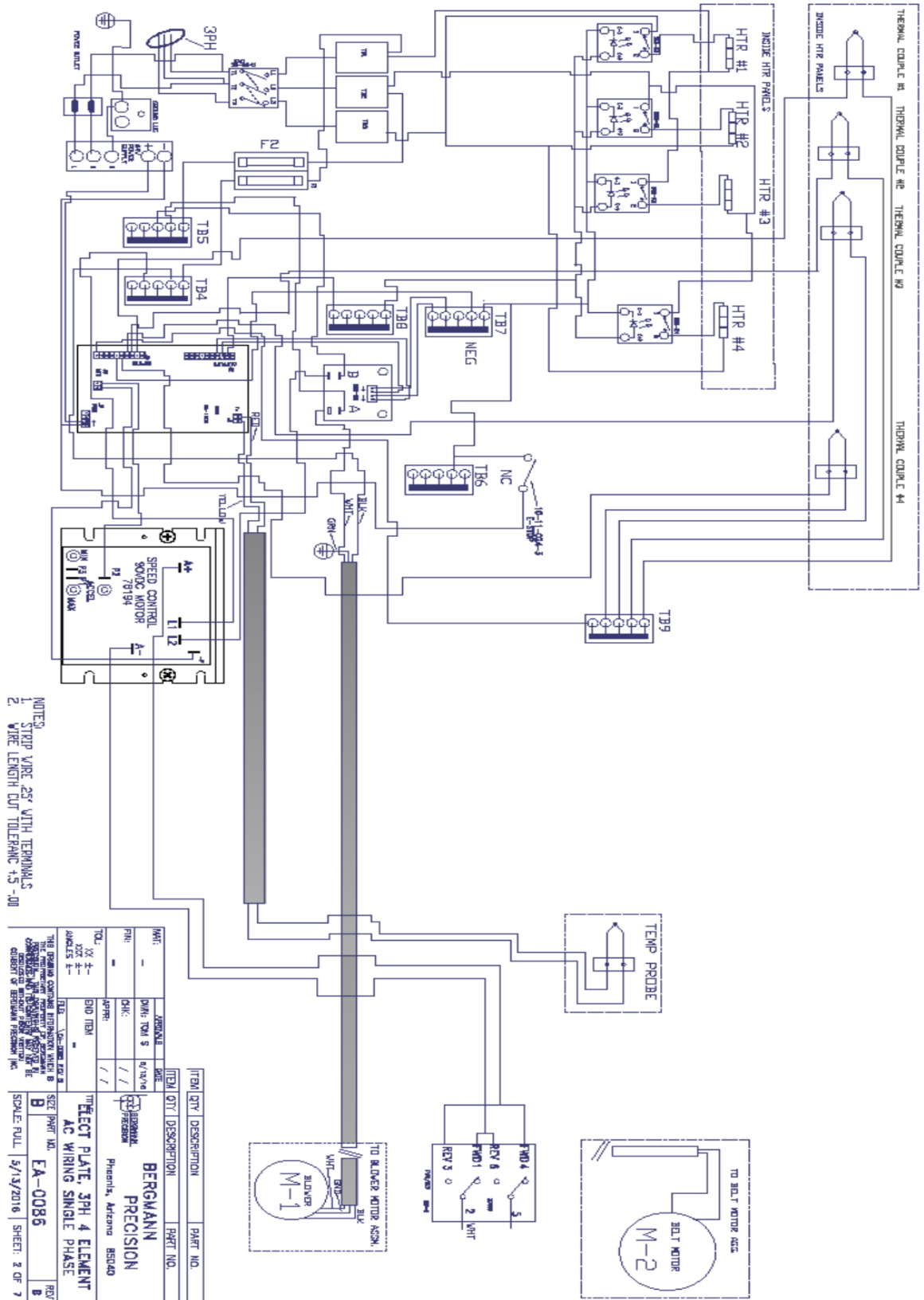

- NOTES:
1. STRIP WIRE 25' WITH TERMINALS.
 2. WIRE LENGTH CUT TOLERANCE +.5-.00

ITEM	QTY	DESCRIPTION	PART NO.
1	1	BERGMANN PRECISION	
2	1	ELECT PLATE, 3PH 4 ELEMENT AC WIRING SINGLE PHASE	EA-0086

DATE: 10/20/16
 DRAWN: TOM S
 CHECKED: / /
 APPROVED: / /
 DESIGNED: / /
 REVISED: / /
 BERGMANN PRECISION
 Phoenix, Arizona 85040
 SCALE: FULL
 SHEET: 2 OF 7

Limited Warranty



Although every effort has been made to provide accurate specifications, Workhorse Products does not assume any liability for damages, whether consequential or incidental, that may result from the use or misuse of the indicated specifications. Workhorse Products requires the use of a licensed industrial electrician for the installation of electrical service to equipment requiring electrical power.

Workhorse Products reserves the right to alter specifications in the manufacture of its products. It is understood and agreed that Seller's liability for any equipment whether liability in contract, in tort, under any warranty, in negligence, in strict liability or otherwise shall not exceed the return of the amount of the purchase price paid by Buyer. Notwithstanding the foregoing provision, under no circumstances shall Seller be liable for special, indirect or consequential damages. The price stated for the equipment is a consideration in limiting Seller's liability. No action regardless of form, arising out of the transactions under this Agreement may be brought by Buyer more than one (1) year after the cause of action has occurred. Our warranty is specified is exclusive and no other warranty, whether written or oral, is expressed or implied. Workhorse Products specifically disclaims the implied warranties of merchantability and fitness for a particular purpose. Equipment manufactured or sold by Workhorse Products is warranted against defects in workmanship and materials for a period of one year from receipt by customer. All warranties initiate from date of shipment to original customer. Replacement parts are covered for the term of the equipment warranty period. Parts not under warranty are covered for thirty (30) days from receipt by customer. Any part found by Workhorse Products to be defective in material or workmanship within the stated warranty period will be replaced or repaired at Workhorse's option without charge.

AFTER OBTAINING AN RMA# SEND RETURNED FREIGHT PREPAID TO 3730 E. Southern Avenue, PHOENIX, AZ 85040 USA.

Written authorization must be obtained from Workhorse before any part will be accepted. Replacement parts are sent out freight collect.

Parts sent out prior to receiving defective require a credit card hold for cost plus freight. Upon return of defective part, if it is deemed that the part was not damaged by customer but failed, the cost of the replacement part will be refunded.

This warranty does not extend to expendable parts such as filters, fuses, elements and brushes. Workhorse does not warrant failure of parts or components resulting from misuse or lack of proper maintenance. Installation, inspection, and

Registration Form	
Company Name: _____	Contact Name: _____
Address: _____ _____	Phone Number: _____
City: _____	Fax Number: _____
State: _____	Email : _____
Country: _____	Cell Number: _____
Zip Code: _____	Serial Number: _____
Model Number: _____	Date Recivied: _____
Date Purchased _____	

Please Fax Registration Form for warranty to take place