

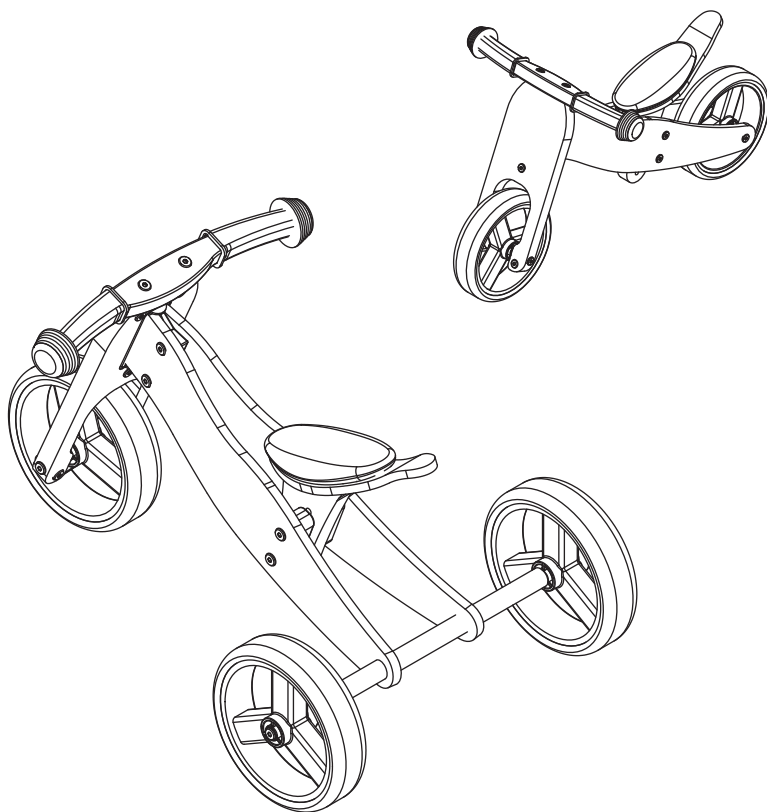

NANO - Balance bike | Assembly guide
NANO - Vélo d'équilibre | Guide d'assemblage
NANO - Bicicleta de equilibrio | Guía de montaje



⚠ WARNING
CHOKING HAZARD - SMALL PARTS
Adult assembly required.
Adult supervision required at all times.

⚠ AVERTISSEMENT
DANGER DE SUFFOCATION - PETITES PIÈCES
Cet article doit être assemblé par un adulte.
La supervision d'un adulte est requise en tout temps.

⚠ ADVERTENCIA
PELIGRO DE ASFIXIA - PIEZAS PEQUEÑAS
El montaje debe estar a cargo de un adulto.
Se requiere la supervisión de un adulto en todo momento.



Due to the small size of the hardware and the sharp points of the screws, these items are potentially hazardous.

Keep all assembly parts and packaging materials out of the reach of children.

Retain packaging information for future reference.

Assembly by an adult required.

Adult supervision required at all times.

To be used by only one rider at a time.

This toy requires skills to avoid falling or collisions, which could result in injuries to the user or third parties.

Teach your child how to brake and stop by slightly lifting the front end of the toy.

Your child should understand and master the braking technique before using the bike.

This bike should be used solely on smooth, level and dry surfaces. Use on any other surface type could affect the proper use of the toy and safety of your child.

Never use this bike on public roads and/or traffic, or near dangerous areas such as water, stairways and slopes.

Never pull the bike with another vehicle.

Your child should always wear a helmet when using this toy.

For your child's safety, properly inspect the condition of the bike before each use. The bike must be maintained in perfect technical condition. All screws, steering, bolts and axles must be checked by an adult before each use, and tightened when needed.

This 2-in-1 balance bike is recommended for children aged 1-3 years old, and supports up to 20kg – 44lbs.



ATTENTION

En raison de la petite taille de la quincaillerie et des pointes tranchantes des vis, elles sont potentiellement dangereuses.

Tenez toutes les pièces d'assemblage et les matériaux d'emballage hors de portée des enfants.

Conservez les informations sur l'emballage pour pouvoir vous y référer ultérieurement.

Ce vélo doit être assemblé par un adulte.

Ce produit doit être utilisé sous la surveillance constante d'un adulte.

Ne doit être utilisé que par un enfant à la fois.

Ce vélo nécessite certaines aptitudes pour éviter les chutes ou les collisions, qui peuvent blesser l'utilisateur ou des tiers.

Apprenez à votre enfant à freiner et à s'arrêter en soulevant légèrement la partie avant du vélo.

Votre enfant doit comprendre et maîtriser la technique de freinage avant d'utiliser le vélo.

Ce vélo doit être utilisé uniquement sur des surfaces lisses, planes et sèches. Évitez d'utiliser sur d'autres types de surface afin de ne pas mettre en danger votre enfant et ne pas endommager le vélo.

N'utilisez jamais ce vélo sur la voie publique ou à proximité de zones dangereuses, notamment près d'un cours d'eau, d'escaliers et d'une pente.

Ne tirez jamais le vélo à l'aide d'un autre véhicule.

Votre enfant doit toujours porter un casque lorsqu'il utilise ce jouet.

Pour la sécurité de votre enfant, inspectez l'état du vélo avant chaque utilisation. Le vélo doit être maintenu en parfait état. Toutes les vis, le guidon, les boulons et les essieux doivent être vérifiés par un adulte avant chaque utilisation et serrés si nécessaire.

Ce vélo d'équilibre 2 en 1 est recommandé pour les enfants âgés de 1 à 3 ans et supporte jusqu'à 20 kg – 44lbs.



Debido al tamaño pequeño de las piezas y a las puntas afiladas de los tornillos, estos elementos pueden ser peligrosos.

Mantenga fuera del alcance de los niños todas las piezas de montaje y los materiales del empaque.

Conserve la información del empaque para referencia futura.

El montaje debe estar a cargo de un adulto.

Se requiere la supervisión de un adulto en todo momento.

Para ser utilizado por un solo niño a la vez.

Este juguete requiere habilidad para evitar caídas o colisiones, con posibles lesiones al usuario o a terceros.

Enséñele a su hijo a frenar y detenerse levantando ligeramente la parte delantera del juguete.

Su hijo debe entender y dominar la técnica de frenado antes de usar la bicicleta.

Esta bicicleta debe usarse únicamente en superficies lisas, niveladas y secas. Su uso en diferentes superficies podría afectar el uso adecuado del juguete y la seguridad de su hijo.

Nunca use esta bicicleta en las vías públicas y carreteras o cerca de áreas peligrosas como agua, escaleras y pendientes.

Nunca tire de la bicicleta con otro vehículo.

Su hijo debe siempre usar un casco cuando use este juguete.

Para la seguridad de su hijo, inspeccione adecuadamente el estado de la bicicleta antes de cada uso. Se debe mantener el perfecto estado técnico de la bicicleta. Todos los tornillos, dirección, pernos y ejes deben ser revisados por un adulto antes de cada uso y apretados cuando sea necesario.

Esta bicicleta sin pedales 2 en 1 se recomienda para niños de 1 a 3 años y soporta hasta 20 kg – 44 lbs.

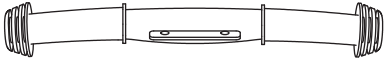

1

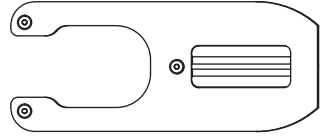

2

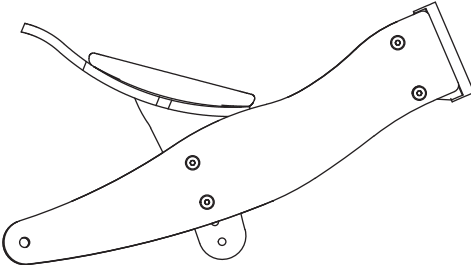

3

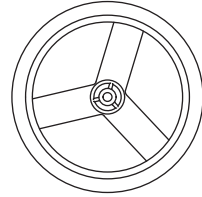

4 X3



A X2

+2 extra



B X1

+2 extra



C X2

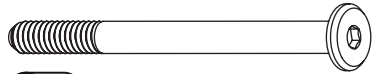

E X1



F X2



H X1



I X1



J X2



K X1

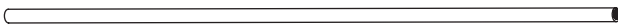

L X1

⚠ WARNING

TWO WHEELS CONVERSION KIT -
KEEP THESE PARTS

⚠ ATTENTION

KIT DE CONVERSION DEUX
ROUES - GARDER CES PIÈCES

⚠ ATENCIÓN:

KIT DE CONVERSIÓN A DOS RUEDAS -
CONSERVE ESTAS PIEZAS



B X2



C X2

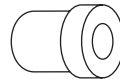

D X2

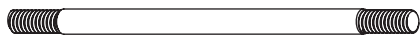

G X1



H X1

01

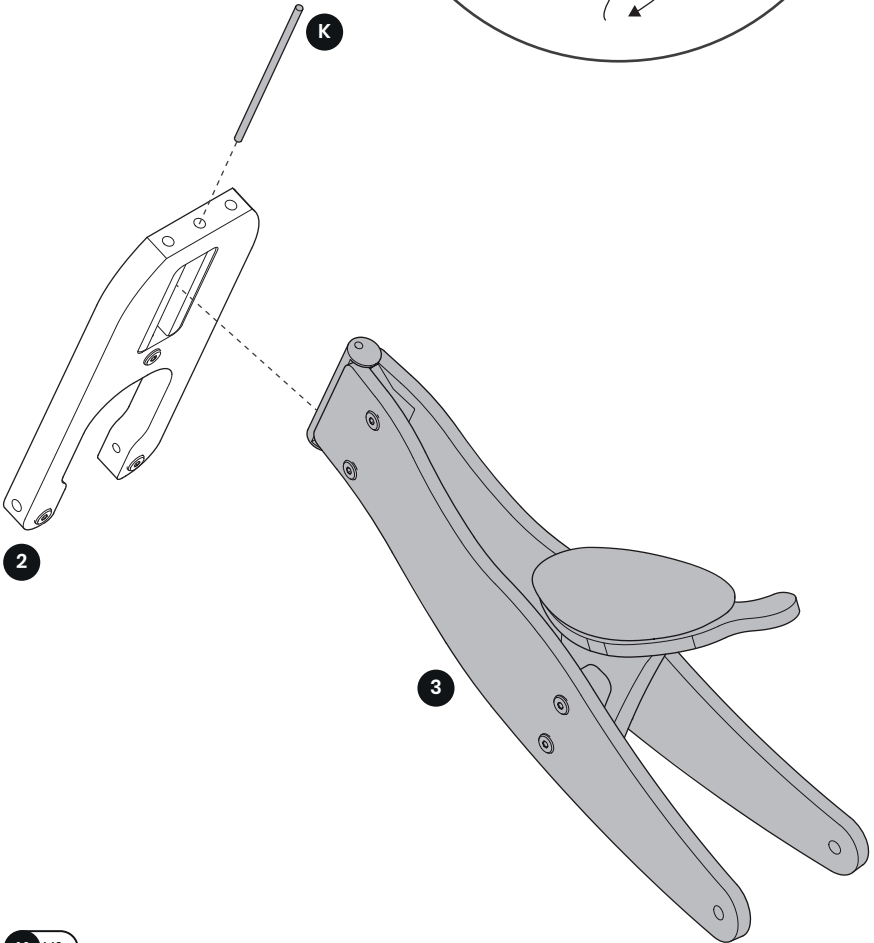
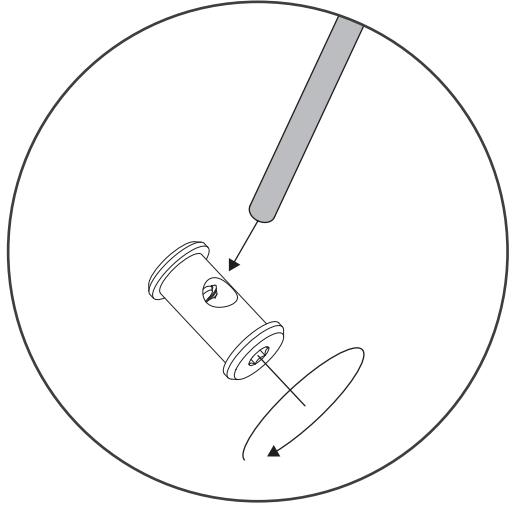

K X1

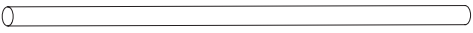

02

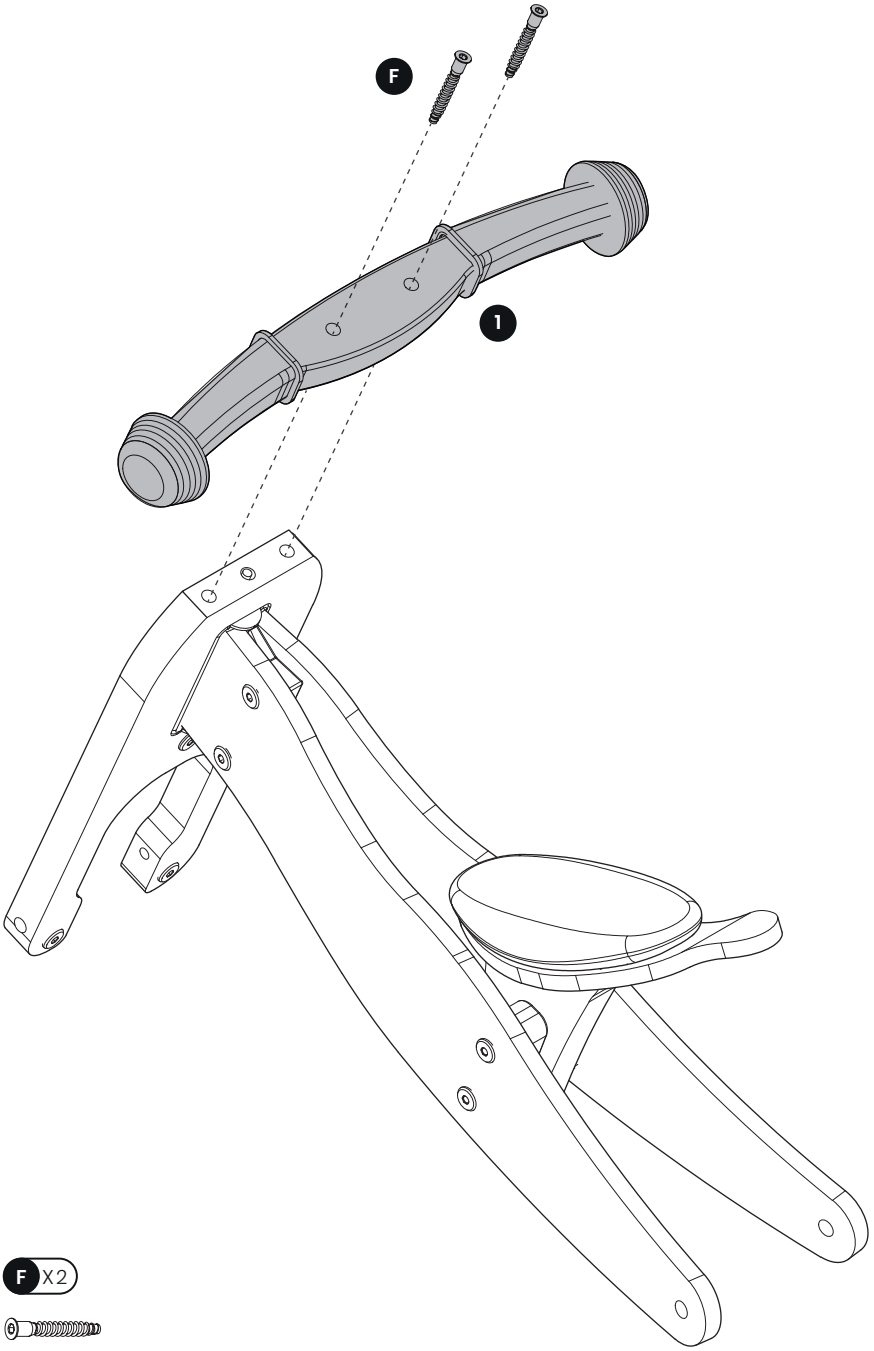

F X2



03

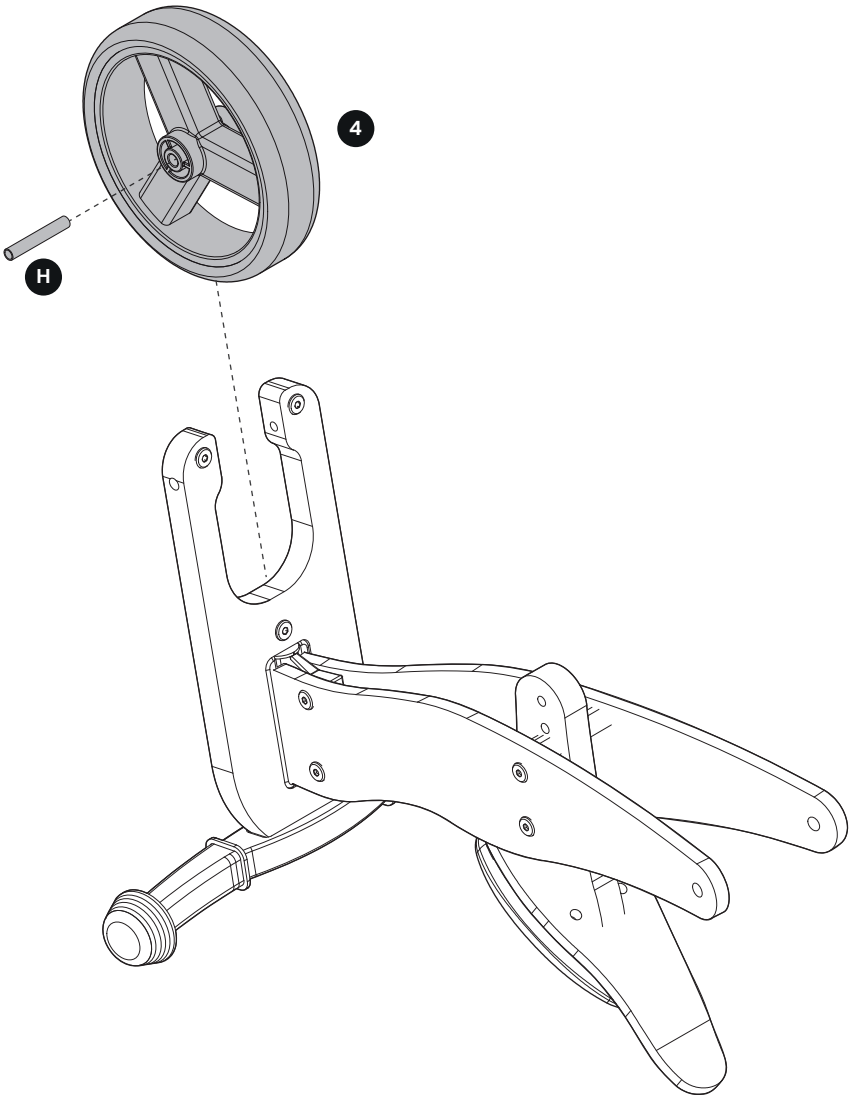

H X1

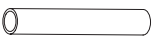

04

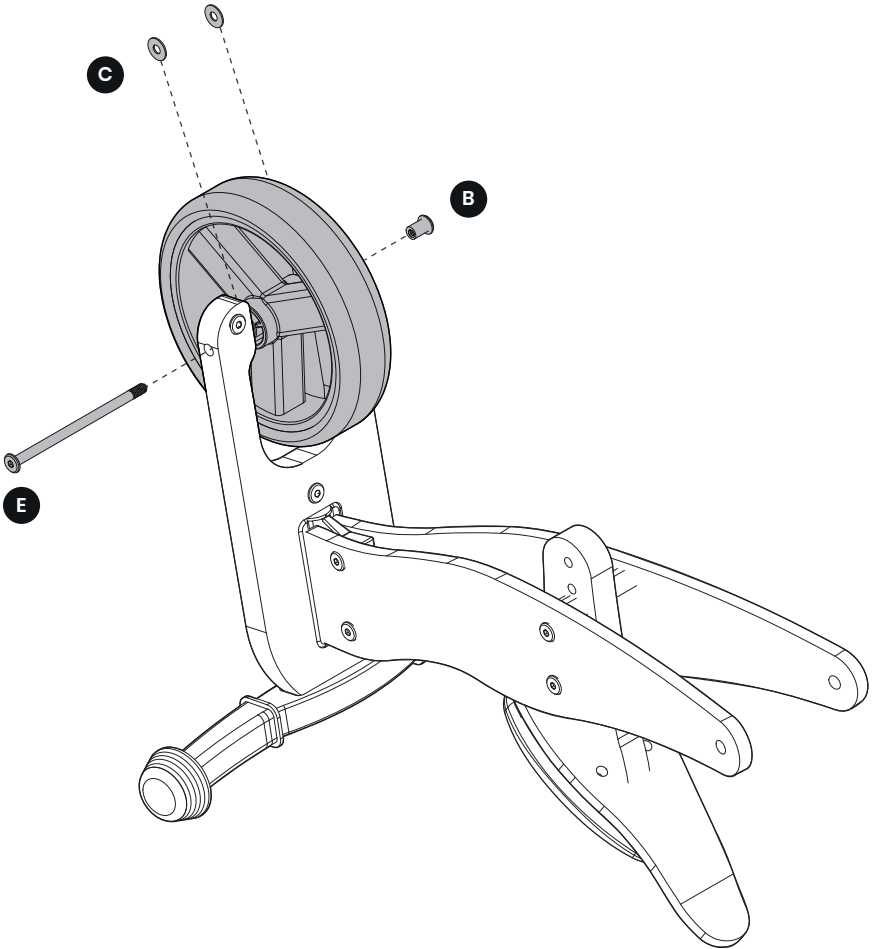

B X1

C X2

E X1

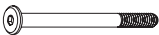

05

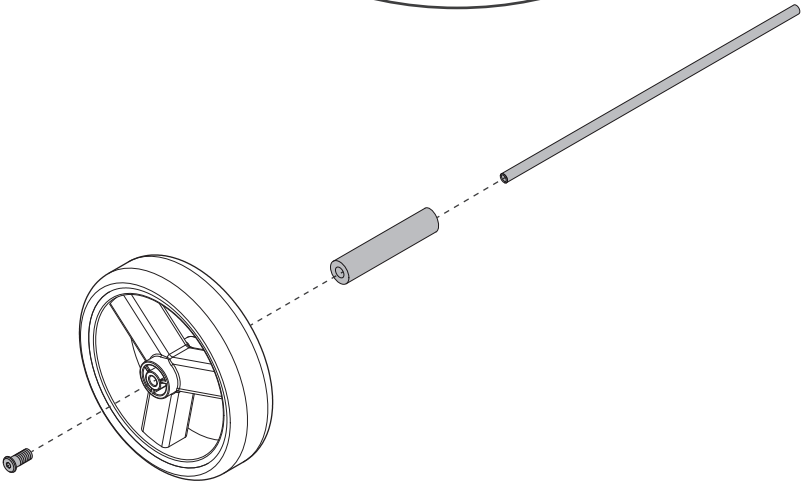
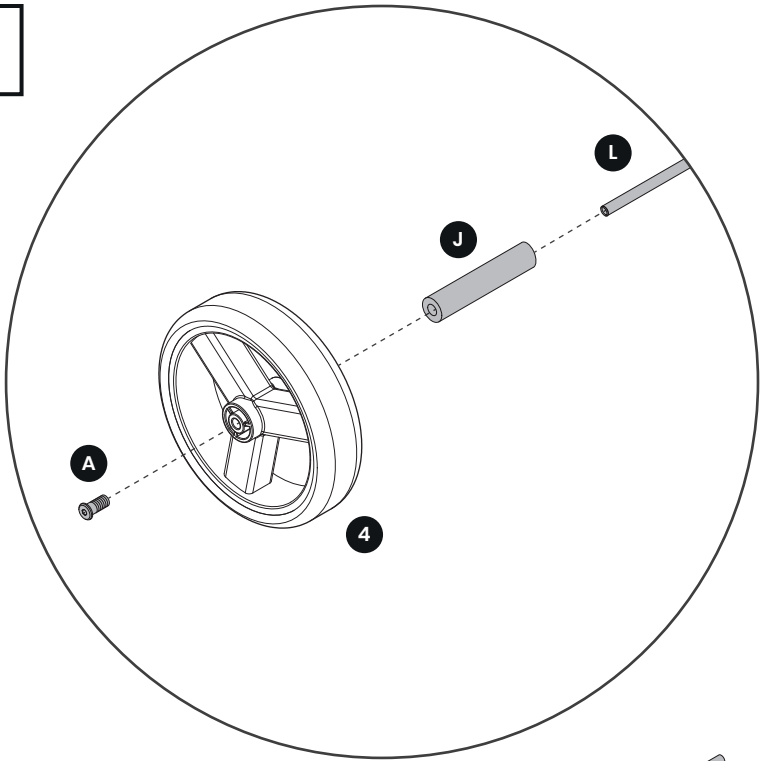

A X1

J X1

L X1

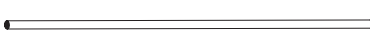
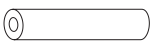

06

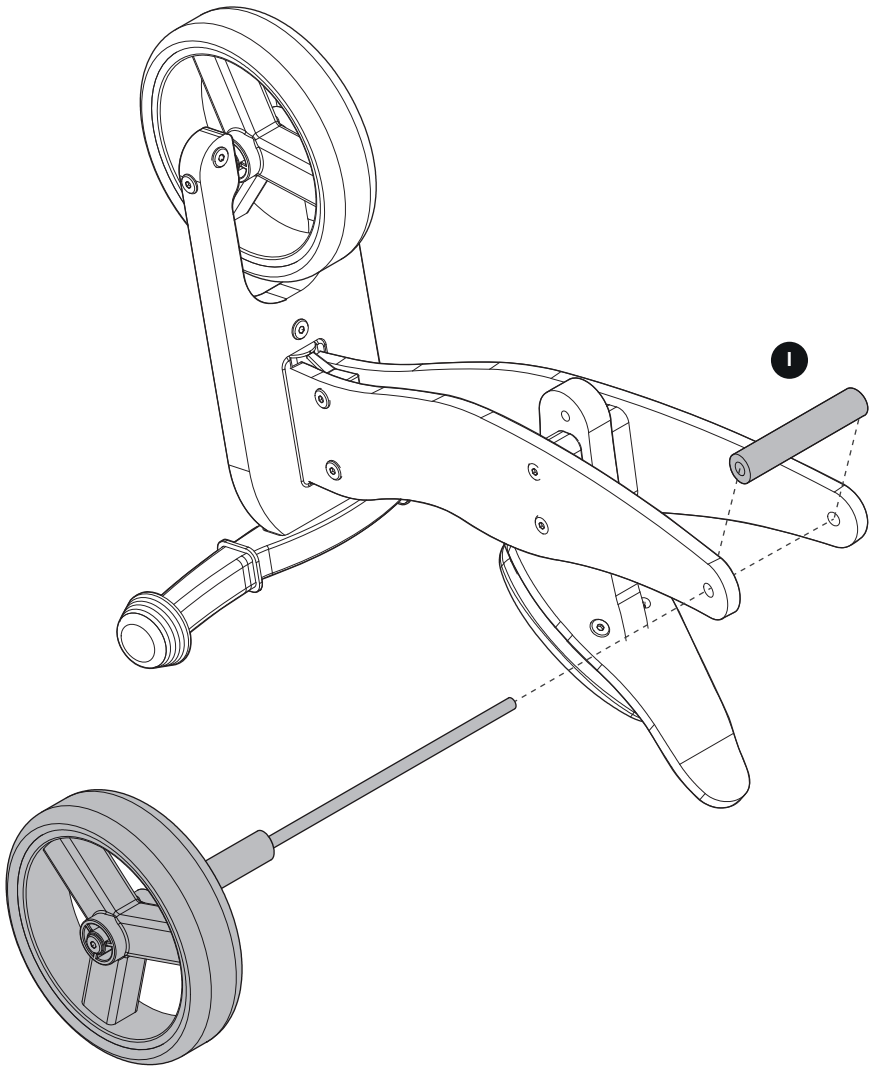

1 X1



07

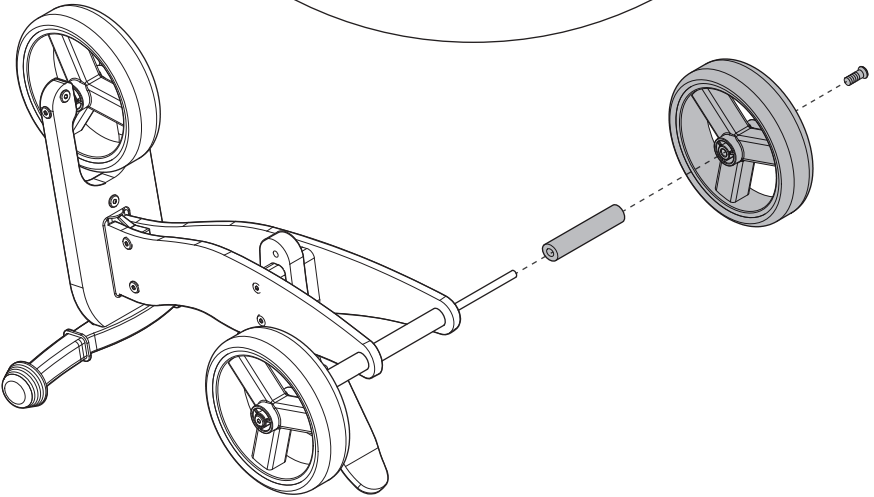
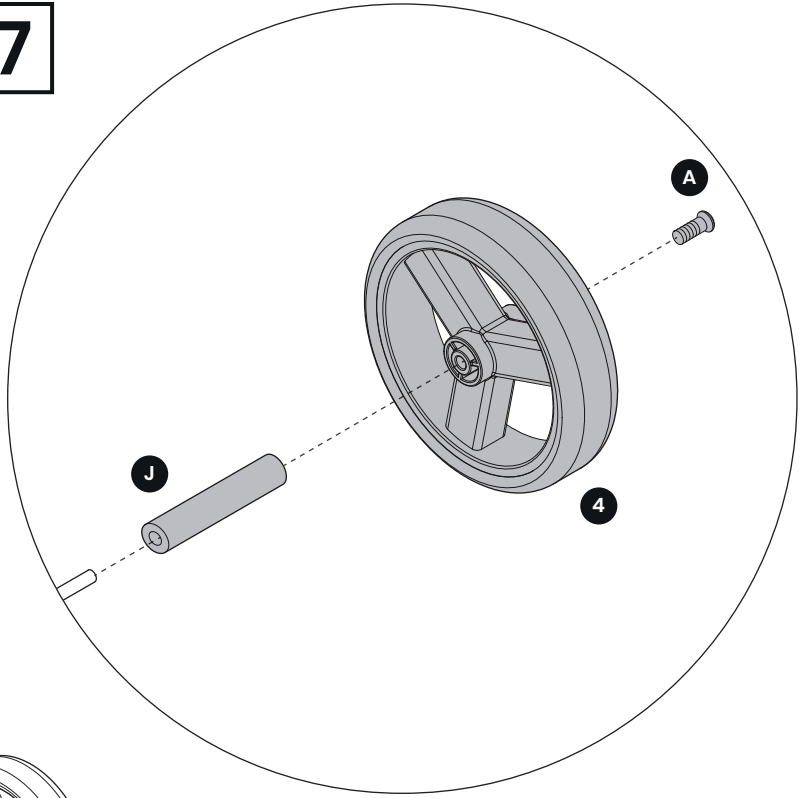

A X1

J X1

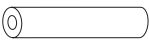

08

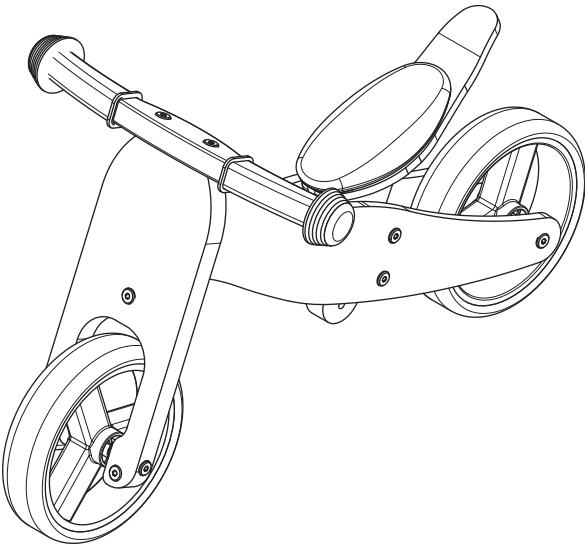
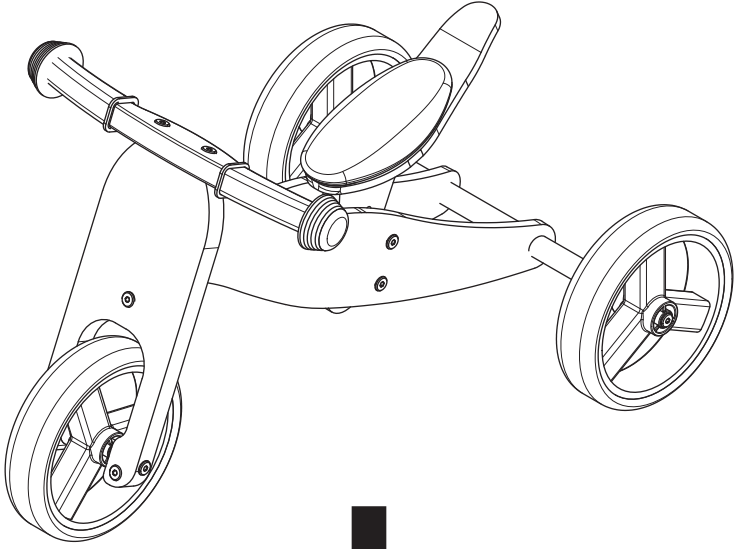

09

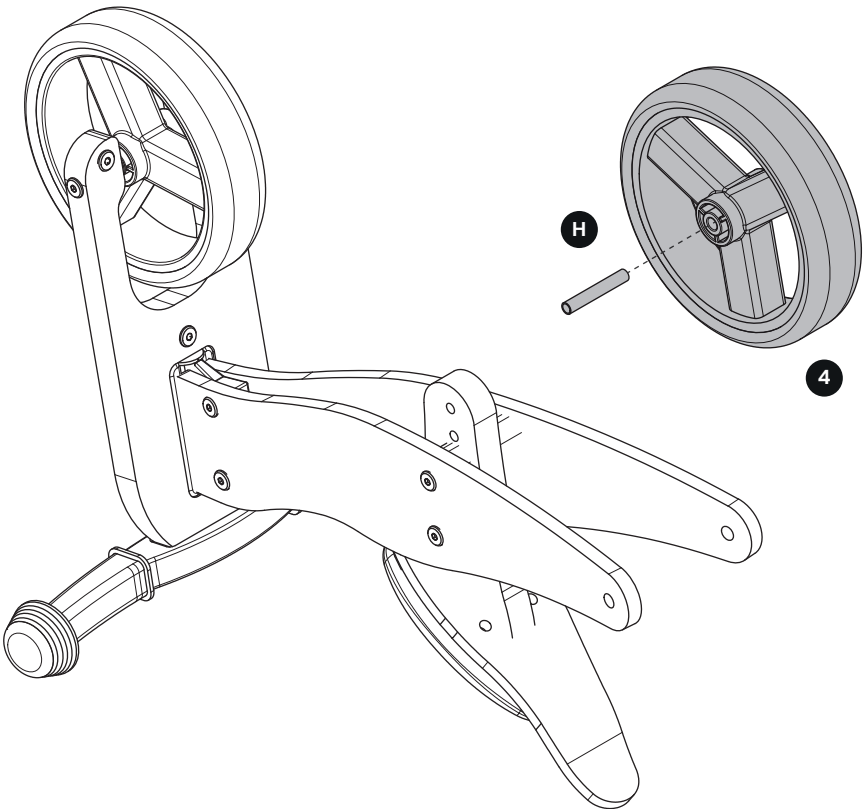
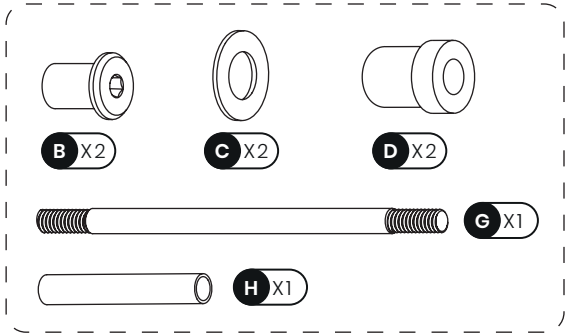

H X1

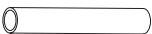

10

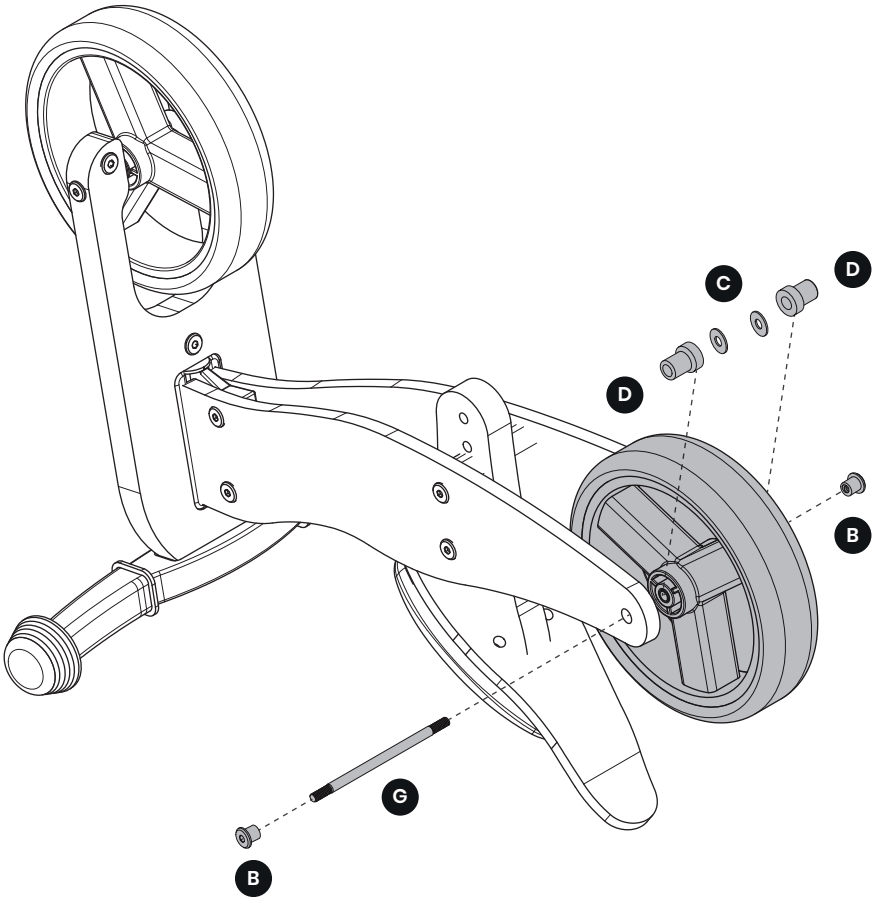

B X2

C X2

D X2

G X1

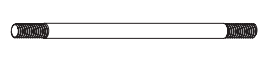



Customer care available 7/7

1-833-901-COCO

Service client disponible 7 jours

1-833-929-COCO

Ofrecemos atención
al cliente los 7 días

1-833-901-COCO



Fast delivery
across North America

Livraison rapide
partout en Amérique du Nord

Entrega rápida en
toda América del Norte



Unique minimalist
designs

Designs minimalistes
exclusifs

Diseños minimalistas
exclusivos



Exclusively online
cocovillage.com

Exclusivement
en ligne

Solo en línea
cocovillage.com

cocovillage.com