

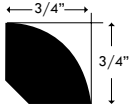
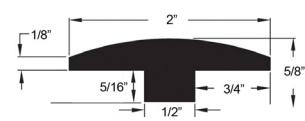

### Product Features:

<b>Size:</b>	1/2" x 5" x Random Length (16" - 71")			
<b>Wood Grade:</b>	Rustic			
<b>Wear Layer Thickness:</b>	2 mm			
<b>Texture/Edge:</b>	Varies by item; Smooth or light hand-scrape, micro-beveled edges			
<b>Coating/Gloss Level:</b>	UV urethane w/ Aluminum Oxide, Ultra-matte			
<b>Species Available/ Janka Hardness:</b>	Acacia - 2250			
<b>Colors:</b>	<u>Smooth</u> Acacia Moorea (REW125SSAMR) Acacia Bora Bora (REW125SSABB)	<u>Hand-scraped</u> Acacia Mana Hand-scraped (REW125SSAMN) Acacia Tiga Hand-scraped (REW125SSATG)		
<b>Moldings:</b>	 Quarter Round	 T-Mold	 Stair Nose	 Reducer

### Technical Specifications:

<b>Packaging:</b>	29.53 SF/CT 36 CT/Pallet
<b>Warranty:</b>	Lifetime Structural Warranty 25 Year Finish Residential Warranty 3 Year Finish Commercial Warranty
<b>Installation:</b>	Glue down, nail down, or float. Not approved for use over radiant heat systems. Please refer to Installation Instructions and Care & Maintenance Guide for complete instructions.
<b>Maintenance:</b>	Bona Hardwood Floor Cleaners, please refer to Reward Care & Maintenance Guide for complete instructions.
<b>Compliance:</b>	All Reward Hardwood products are manufactured in compliance with the <u>Food, Conservation, and Energy Act of 2008</u> (Lacey Act amendment), and are in full compliance with California's Airborne Toxic Control Measure (CARB).
<b>Formaldehyde Emissions (per ASTM D6007)*:</b>	<0.005ppm

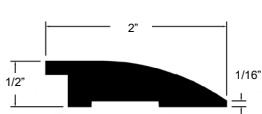
\*All test results come from an independent, CARB-accredited U.S. testing laboratory and are verified/updated periodically.



Visit us at [rewardflooring.com](http://rewardflooring.com)

*where luxury and value meet*