

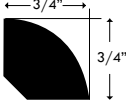
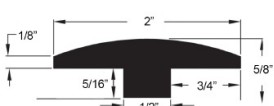
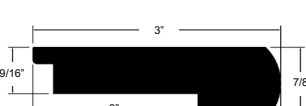
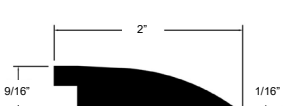

Product Features:

Size:	9/16" x 6" x Random Length (16" - 94")		
Wood Grade:	Natural		
Wear Layer Thickness:	4 mm		
Texture/Edge:	Soft hand-scraped, Micro-beveled edges		
Treatment:	Natural/Not Smoked or Carbonized		
Coating/Gloss Level:	UV urethane w/ Aluminum Oxide, Satin		
Species Available/ Janka Hardness:	Maple - 1450		
Colors:	Maple Kona (REW9166CKN8) Maple Kahlua (REW9166CKL8) Maple Horizon (REW9166CHZ8)		
Moldings:	 <p>Quarter Round</p>	 <p>T-Mold</p>	 <p>Stair Nose</p>
			 <p>Reducer</p>

Technical Specifications:

Packaging:	31.50 SF/CT 52 CT/Pallet		
Warranty:	Lifetime Structural Warranty 25 Year Finish Residential Warranty 3 Year Finish Commercial Warranty		
Installation:	Glue down, staple, or float. Not approved for use over radiant heat systems. Please refer to Installation Instructions and Care & Maintenance Guide for complete instructions.		
Maintenance:	Bona Hardwood Floor Cleaners, please refer to Reward Care & Maintenance Guide for complete instructions.		
Compliance:	<p>All Reward Hardwood products are manufactured in compliance with the <u>Food, Conservation, and Energy Act of 2008</u> (Lacey Act amendment), and are in full compliance with California's Airborne Toxic Control Measure (CARB).</p> <div style="display: flex; align-items: center;">  <div style="margin-left: 10px;"> <p>FloorScore® Certified. FloorScore® is a certification program established by the Resilient Covering Institute (RFCI) for hard surface flooring and flooring adhesive products that meet strict indoor air quality (IAQ) requirements. Products bearing the FloorScore label meet the indoor air quality emissions criteria of LEED, CHPS, the Green Guide for Health Care, and are recognized by a long list of healthy building programs.</p> </div> </div>		