

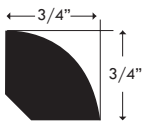
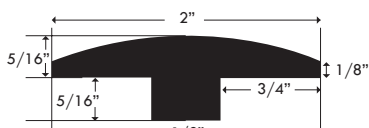
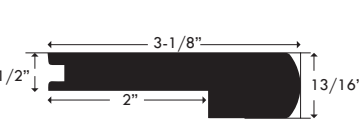
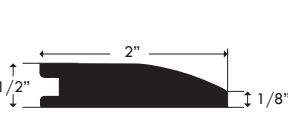

Product Features:	
Size:	1/2" x 5" x Random Length (16" - 47")
Wood Grade:	Character
Wear Layer Thickness:	2 mm
Texture/Edge:	Hand-scraped w/ character distressing, Micro-beveled edges
Coating/Gloss Level:	UV urethane w/ Aluminum Oxide, Semi-Gloss
Species Available/ Janka Hardness:	Hickory - 1820 Maple - 1450 Walnut - 1010
Colors:	Hickory Natural (REW 125CHNT) Hickory Rawhide (REW 125CHR) Hickory Tobacco (REW 125CHT) Maple Natural (REW 125CMNT) Maple Smoke (REW 125CMK) Maple Saddle (REW 125CMSD) Maple Whiskey (REW 125CMW) Walnut Natural (REW125CWN)
Moldings:	   

Technical Specifications:	
Packaging:	28.7 SF/CT 52 CT/Pallet
Warranty:	Lifetime Structural Warranty 25 Year Finish Residential Warranty 3 Year Finish Commercial Warranty
Installation:	Glue down, float or staple. Please refer to Installation Instructions and Care & Maintenance Guide for complete instructions.
Maintenance:	Bona Hardwood Floor Cleaners, please refer to Reward Care & Maintenance Guide for complete instructions.
Compliance:	<p>All Reward Hardwood products are manufactured in compliance with the <u>Food, Conservation, and Energy Act of 2008</u> (Lacey Act amendment), and are in full compliance with California's Airborne Toxic Control Measure (CARB).</p>  <p>FloorScore® Certified. FloorScore® is a certification program established by the Resilient Floor Covering Institute (RFCI) for hard surface flooring and flooring adhesive products that meet strict indoor air quality (IAQ) requirements. Products bearing the FloorScore label meet the indoor air quality emissions criteria of LEED, CHPS, the Green Guide for Health Care, and are recognized by a long list of healthy building programs.</p>
MSDS:	Not required for UV cured finish.
Formaldehyde Emissions (per ASTM D6007)*:	0.013ppm

*All test results come from an independent, CARB-accredited U.S. testing laboratory and are verified/updated periodically.