

ASSEMBLY INSTRUCTIONS

Step 6

Attach Reverse Crunch Handle (9) to Seat Pad Frame (6). Use Internal Hex Cap Screw M8*40 (15) and Arc Washer D8 (20). Tighten the screws.

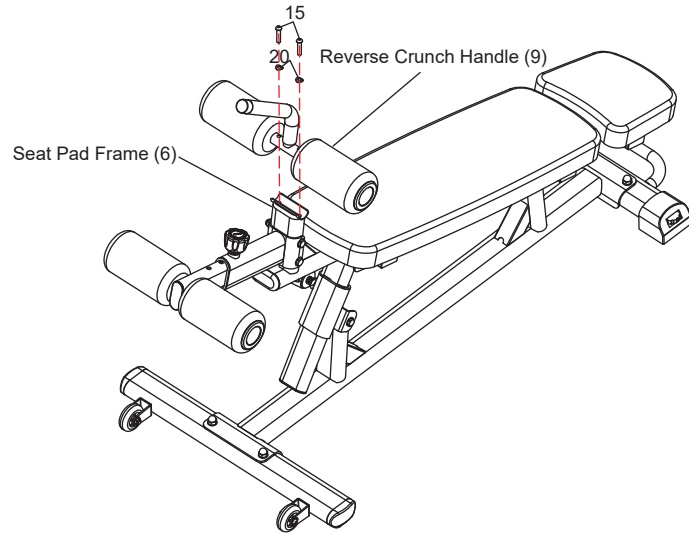

ADJUSTMENT INSTRUCTIONS

Adjust the feet supporting frame to a comfortable position. Tighten the screw.

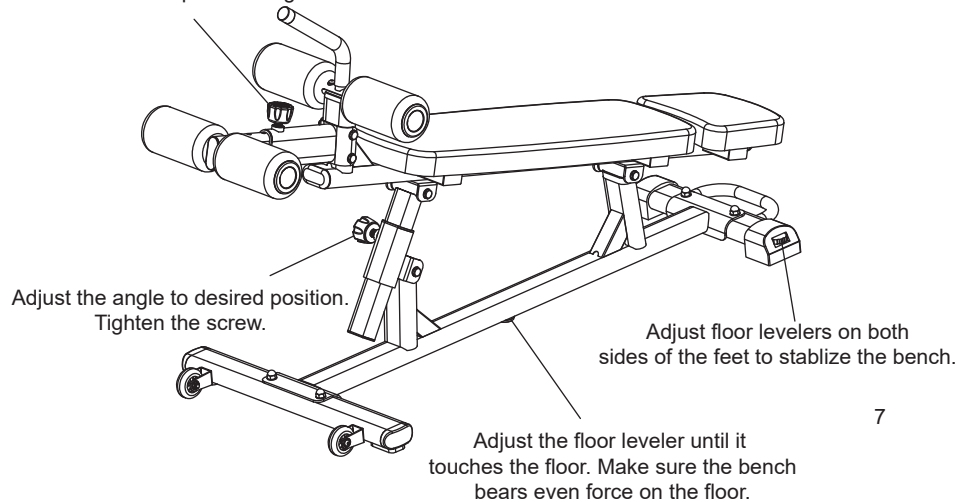

7



www.finerform.com

SKU: FF-TB011389

SKU: FF-TB011390

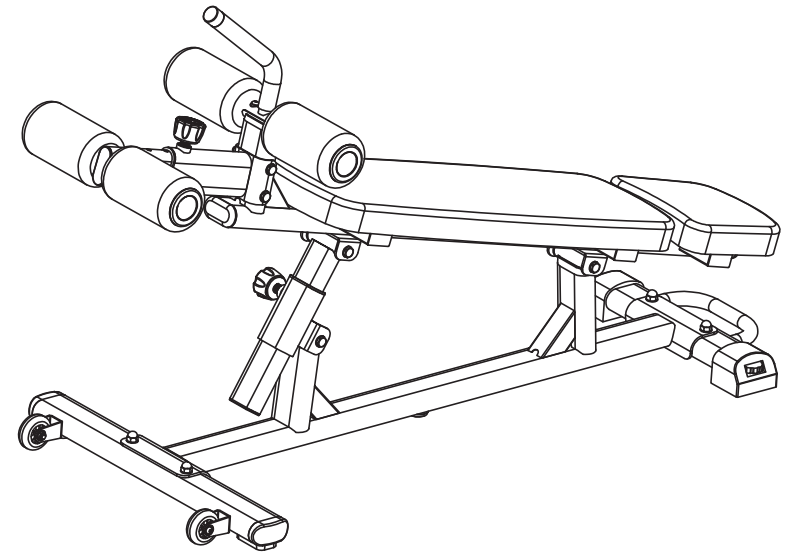

Finer Form Situp Elite

User's Manual

Thank you for your purchase.
Please contact us if you have difficulty with assembly or need replacement parts.
Finer Form Customer Care is here to assist you.

Email: info@finerform.com

Please attach your name and order number so that we can assist you further.

For exercise instruction videos, please check out our Youtube Channel: Finer Form

Visit **finerform.com** for savings on more gym-quality fitness equipment
for your home or office.

Enjoy the convenience and simplicity of working out where, and when you need to.

LIMITED WARRANTY

For a period of 1 year from date of delivery, Finer Form warrants that this product will be free from defects in materials and workmanship.

This warranty is not transferable.

Finer Form will not be liable for any loss or damage, including incidental or consequential damages of any kind, whether based upon warranty, contract or negligence, and arising in connection with the sale, use or repair of the product.

This warranty does not cover damage caused by accident (including in transit), repairs or attempted repairs by any person not authorized by Finer Form, or by vandalism, misuse, abuse, or alteration.

In order to obtain service under this warranty, use the following procedure:

- 1) Contact customer service info@finerform.com
- 2) Be sure to include the order number, receipt, name, phone number, and brief statement concerning the part in question.

@Finer Form. All rights reserved.

ASSEMBLY INSTRUCTIONS

Step 4

Attach Seat Pad Frame (6) to Adjustment Tube (5) and Base Frame (1). Use Lock Nut M10 (17), Flat Washer D10 (18) and Screw M10*110 (13). Tighten the screws.

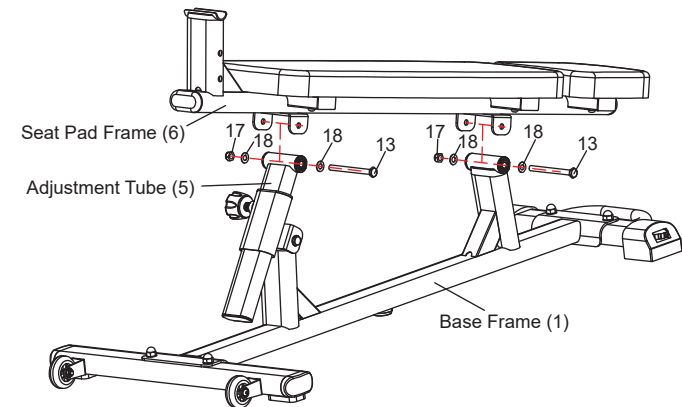

Step 5

Attach Feet Adjustment Frame (7) to Seat Pad Frame (6). Use Screw M10*100 (14), Lock Nut M10 (17), and Flat Washer D10 (18). Tighten the screws. Insert Feet Supporting Frame (8) into Feet Adjustment Frame (7).

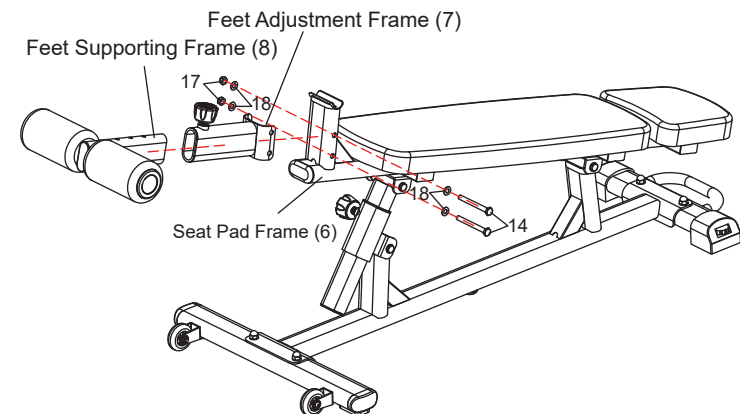

ASSEMBLY INSTRUCTIONS

Step 2

Attach Adjustment Frame (4) to Base Frame (1). Use Screw M10*110 (13), Flat Washer D10 (18), and Lock Nut M10 (17). Tighten the screws. Insert Adjustment Tube (5) into Adjustment Frame (4).

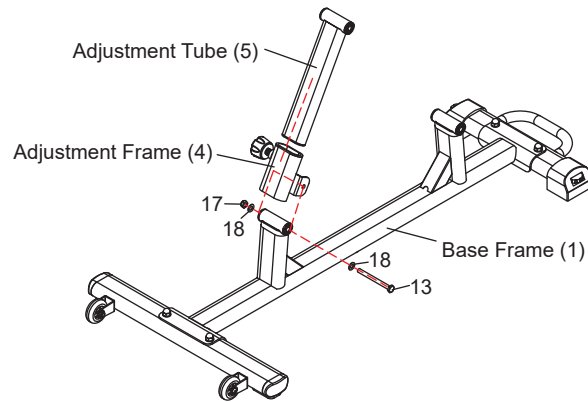

Step 3

Attach Head Pad (11) and Back Pad (10) to Seat Pad Frame (6). Use Internal Hex Cap Screw M8*40 (15) and Flat Washer D8 (19). Tighten the screws.

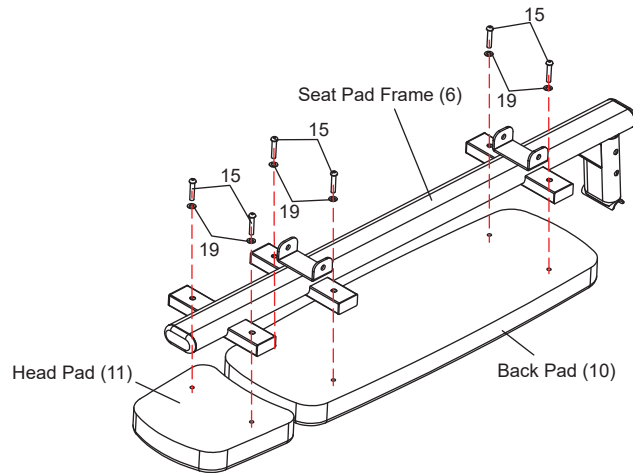

PRODUCT SAFETY

WARNING: Please consult a physician before exercising or using this equipment. This equipment should not be used without your physician's review and approval. If you have any of the following conditions or use any of the following medications, please do not use this bench –

- High doses of aspirin or anti-coagulant medications
- Bone ailments that include fractures, unhealed fractures, Surgical pins, plates or supports, or Osteoporosis
- Hernias
- Heart conditions, heart weakness or circulatory issues that you are being treated for
- Ear infections or balance disorders
- Injuries to the back, spinal injuries, extremely swollen joints or cerebral sclerosis
- Pregnancy
- Obesity

The Maximum Weight Capacity for this product is 660 lbs or 300kgs. Only one person should use this piece of equipment at one time.







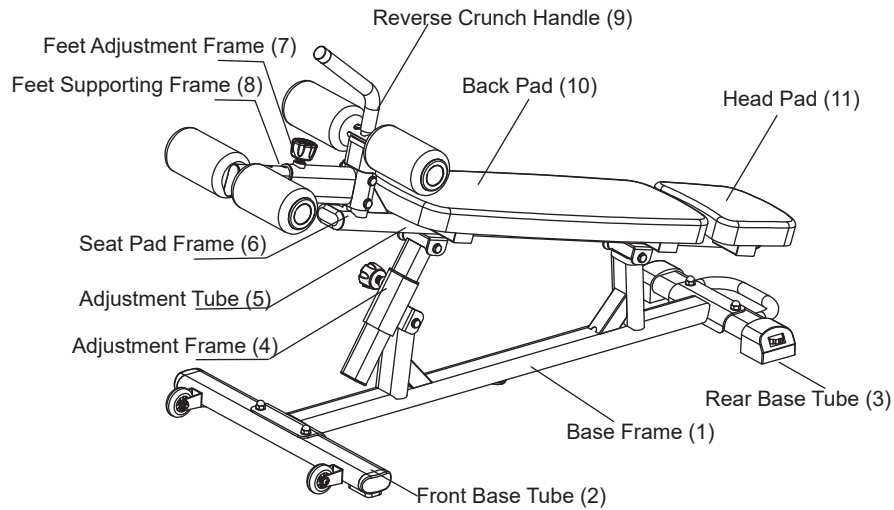

This equipment was designed to be used safely and responsibly. Please read all instructions and use caution before using this equipment. All nuts, bolts and screws included in the package should be used during assembly. Please consult the assembly instructions as you assemble the equipment, and then follow these safety instructions:

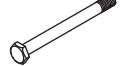
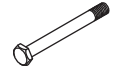
- 1) Consult your doctor or a physician before using this exercise equipment.
- 2) Use extreme care as you get on and off of the bench.
- 3) Stop use of equipment if you experience dizziness, light-headedness or you feel faint. Then contact your doctor or a physician.
- 4) Stop using this equipment if you feel any type of pain or discomfort.
- 5) Wear clothing appropriate to exercise and fitness when using this piece of equipment.
- 6) Do not allow children to operate this equipment.
- 7) Keep pets away from equipment while exercising.
- 8) Cease using this equipment if you feel nauseous or dizzy during a workout.
- 9) Do not operate equipment if it is malfunctioning or is damaged.
- 10) Place bench on a level surface. Do not place bench outside or near water.
- 11) Do not place hands, feet, fingers or toes near any moving parts.
- 12) Do not insert any item into open parts of the bench.
- 13) Do not wear long jewelry, baggy or loose clothing, or long hair while exercising on the bench.
- 14) No individual under 12 should attempt to operate this bench





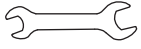

PRODUCT DIAGRAM

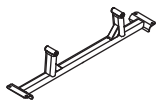

HARDWARE LIST

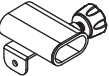
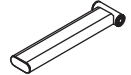
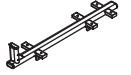
Part 12  Carriage Bolt M10*55 x4	Part 13  Screw M10*110 x3	Part 14  Screw M10*100 x2	Part 15  Internal Hex Cap Screw M8*40 x8
Part 16  Cap Nut M10 x4	Part 17  Lock Nut M10 x5	Part 18  Flat Washer D10 x14	Part 19  Flat Washer D8 x8
Part 20  Arc Washer D8 x2	Part 21  Fork Wrench x2	Part 22  Hex Wrench x1	

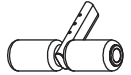
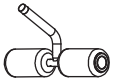
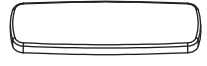
PART LIST

Part 1  Base Frame x1	Part 2  Front Base Tube x1	Part 3  Rear Base Tube x1	Part 4  Adjustment Frame x1
Part 5  Adjustment Tube x1	Part 6  Seat Pad Frame x1	Part 7  Feet Adjustment Frame x1	Part 8  Feet Supporting Frame x1
Part 9  Reverse Crunch Handle x1	Part 10  Back Pad x1	Part 11  Head Pad x1	

ASSEMBLY INSTRUCTIONS

Step 1

Attach Front Base Tube (2) and Rear Base Tube (3) to Base Frame (1). Use Carriage Bolt M10*55 (12), Cap Nut M10 (16), and Flat Washer D10 (18). Tighten the screws.

