

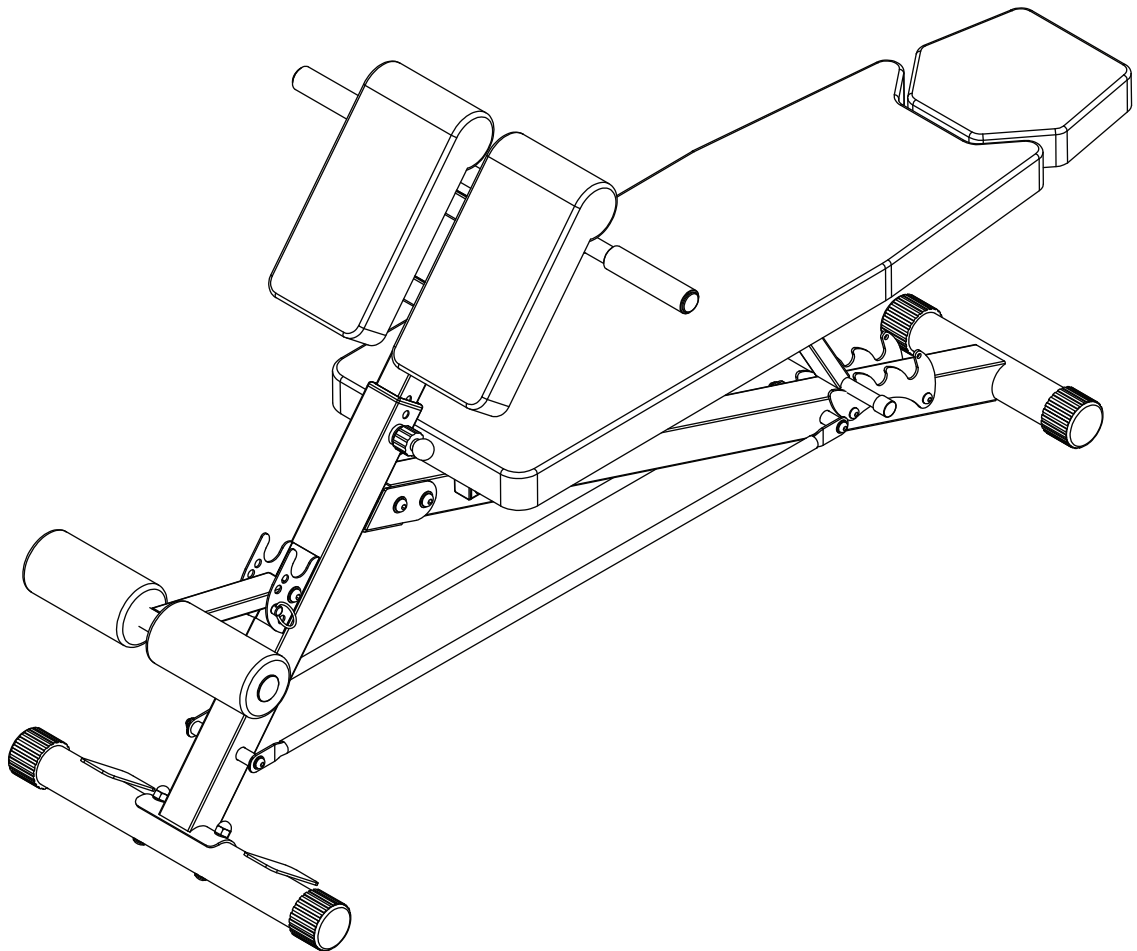

FINER FORM

www.finerform.com

**Please Read User Manual Before
Assembling and Using the Bench**



Multi-Functional Weight Bench

User's Manual

SKU: FF-TB011384

Thank You!

Before we get started, we want to thank you for choosing Finer Form for your new exercise bench. We know you have many choices for at-home exercise equipment, so thank you for joining so many others and choosing us!

Customer Service: Contact Us First!

- If you have any questions about assembling the bench, missing parts or pieces, or you need replacement parts, we want to help you!
- Email: info@finerform.com
- It helps if you can include a picture or video of any issues you may be having
- Please include your order ID so that we can help you even more quickly

For exercise instruction videos, please check out our Youtube Channel: **Finer Form**

Visit [finerform.com](https://www.finerform.com) for savings on more gym-quality fitness equipment

Product Safety

WARNING: Please consult a physician before exercising or using this equipment. This equipment should not be used without your physician's review and approval. If you have any of the following conditions or use any of the following medications, please do not use this bench –

- High doses of aspirin or anti-coagulant medications
- Bone ailments that include fractures, unhealed fractures, Surgical pins, plates or supports, or Osteoporosis
- Hernias
- Heart conditions, heart weakness or circulatory issues that you are being treated for
- Ear infections or balance disorders
- Injuries to the back, spinal injuries, extremely swollen joints or cerebral sclerosis
- Pregnancy
- Obesity

The Maximum Weight Capacity for this product is 400 lbs. Only one person should use this piece of equipment at one time.





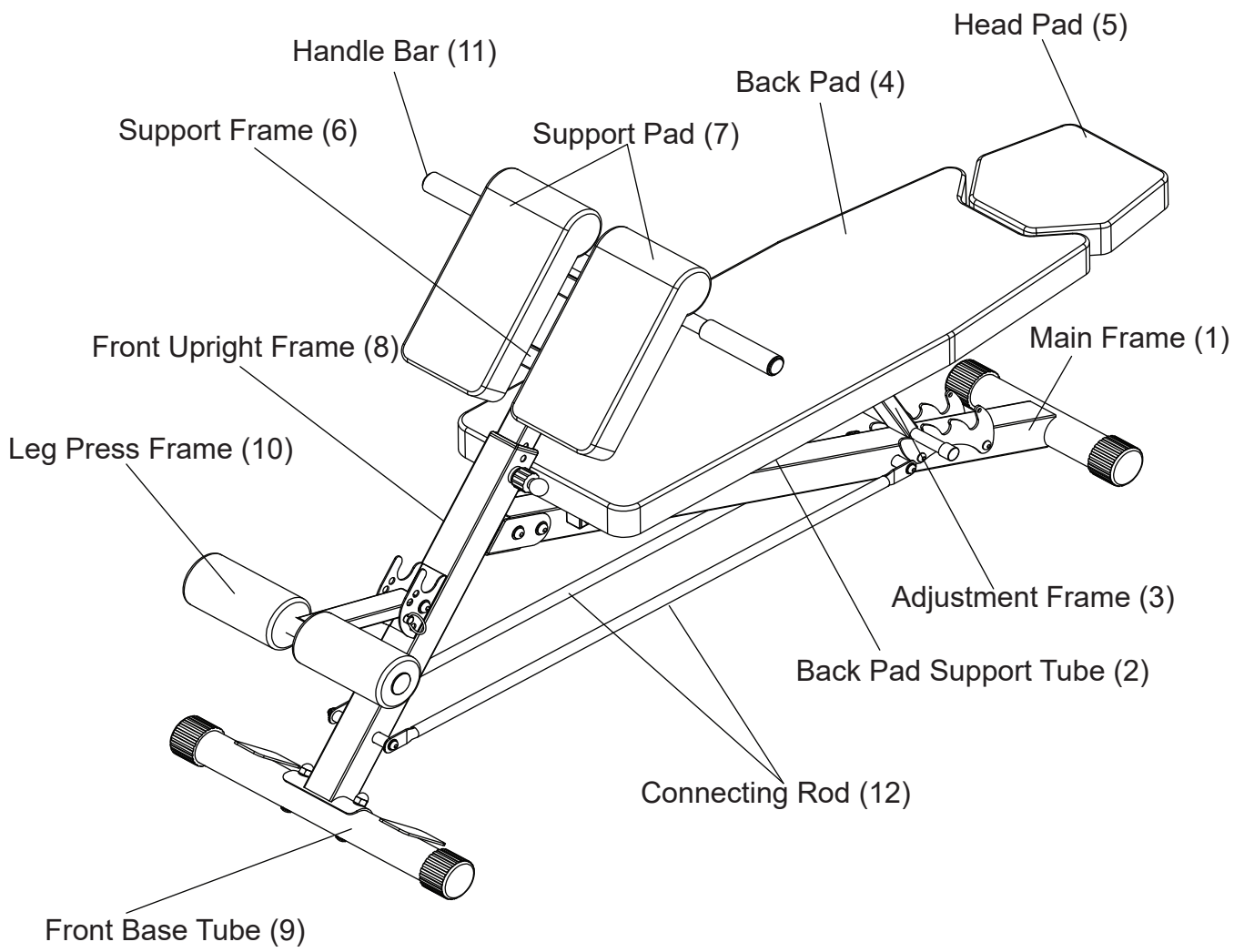

This equipment was designed to be used safely and responsibly. Please read all instructions and use caution before using this equipment. All nuts, bolts and screws included in the package should be used during assembly. Please consult the assembly instructions as you assemble the equipment, and then follow these safety instructions:

- 1) Consult your doctor or a physician before using this exercise equipment.
- 2) Use extreme care as you get on and off of the bench.
- 3) Stop use of equipment if you experience dizziness, light-headedness or you feel faint. Then contact your doctor or a physician.
- 4) Stop using this equipment if you feel any type of pain or discomfort.
- 5) Wear clothing appropriate to exercise and fitness when using this piece of equipment.
- 6) Do not allow children to operate this equipment.
- 7) Keep pets away from equipment while exercising.
- 8) Cease using this equipment if you feel nauseous or dizzy during a workout.
- 9) Do not operate equipment if it is malfunctioning or is damaged.
- 10) Place bench on a level surface. Do not place bench outside.
- 11) Do not place hands, feet, fingers or toes near any moving parts.
- 12) Do not insert any item into open parts of the bench.
- 13) Do not wear long jewelry, baggy or loose clothing, or long hair while exercising on the bench.
- 14) No individual under the age of 12 should attempt to operate this bench

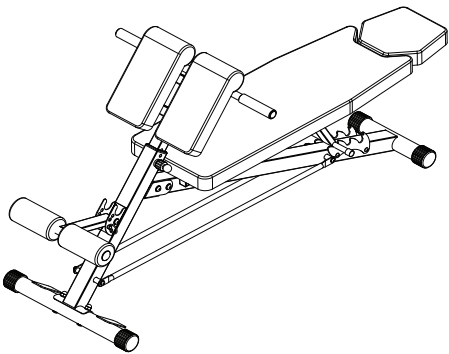
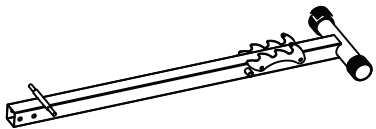

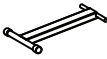

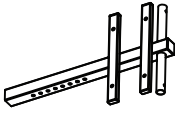
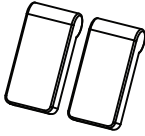
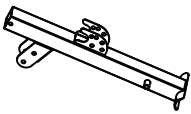
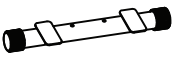
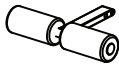

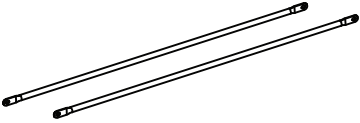



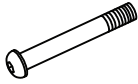

Product Diagram

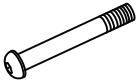

PART LIST

	<p>Part 1</p>  <p>Main Frame x1</p>
	<p>Part 2</p>  <p>Back Pad Support Tube x2</p>
<p>Part 3</p>  <p>Adjustment Frame x1</p>	<p>Part 4</p>  <p>Back Pad x1</p>
<p>Part 5</p>  <p>Head Pad x1</p>	<p>Part 6</p>  <p>Support Frame x1</p>
<p>Part 7</p>  <p>Support Pad x2</p>	<p>Part 8</p>  <p>Front Upright Frame x1</p>
<p>Part 9</p>  <p>Front Base Tube x1</p>	<p>Part 10</p>  <p>Leg Press Frame x1</p>
<p>Part 11</p>  <p>Handle Bar x2</p>	<p>Part 12</p>  <p>Connecting Rod x2</p>

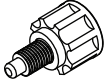
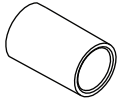
HARDWARE LIST

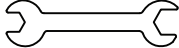
<p>Part 13</p>  <p>Carriage Bolt M8*60 x2</p>	<p>Part 14</p>  <p>Arc Washer x2</p>	<p>Part 15</p>  <p>Cap Nut M8 x2</p>	<p>Part 16</p>  <p>Internal Hex Cap Screw M10*70 x2</p>
<p>Part 17</p>  <p>Flat Washer D8 x10</p>	<p>Part 18</p>  <p>Internal Hex Cap Screw M10*60 x1</p>	<p>Part 19</p>  <p>Internal Hex Cap Screw M8*35 x10</p>	<p>Part 20</p>  <p>Flat Washer D10 x12</p>
<p>Part 21</p>  <p>Internal Hex Cap Screw M10*115 x2</p>	<p>Part 22</p>  <p>Nylon Lock Nut M10 X7</p>	<p>Part 23</p>  <p>Ball Lock Pin with Grip Handle x1</p>	<p>Part 24</p>  <p>Adjustment Knob x1</p>
<p>Part 25</p>  <p>Plug x4</p>	<p>Part 26</p>  <p>Hex Wrench x1</p>	<p>Part 27</p>  <p>Hex Wrench x1</p>	<p>Part 28</p>  <p>Fork Wrench x1</p>



BEFORE ASSEMBLY

We recommend you to tighten all screws after all steps are done, instead of tightening screws at every step.

ASSEMBLY INSTRUCTIONS

Step 1

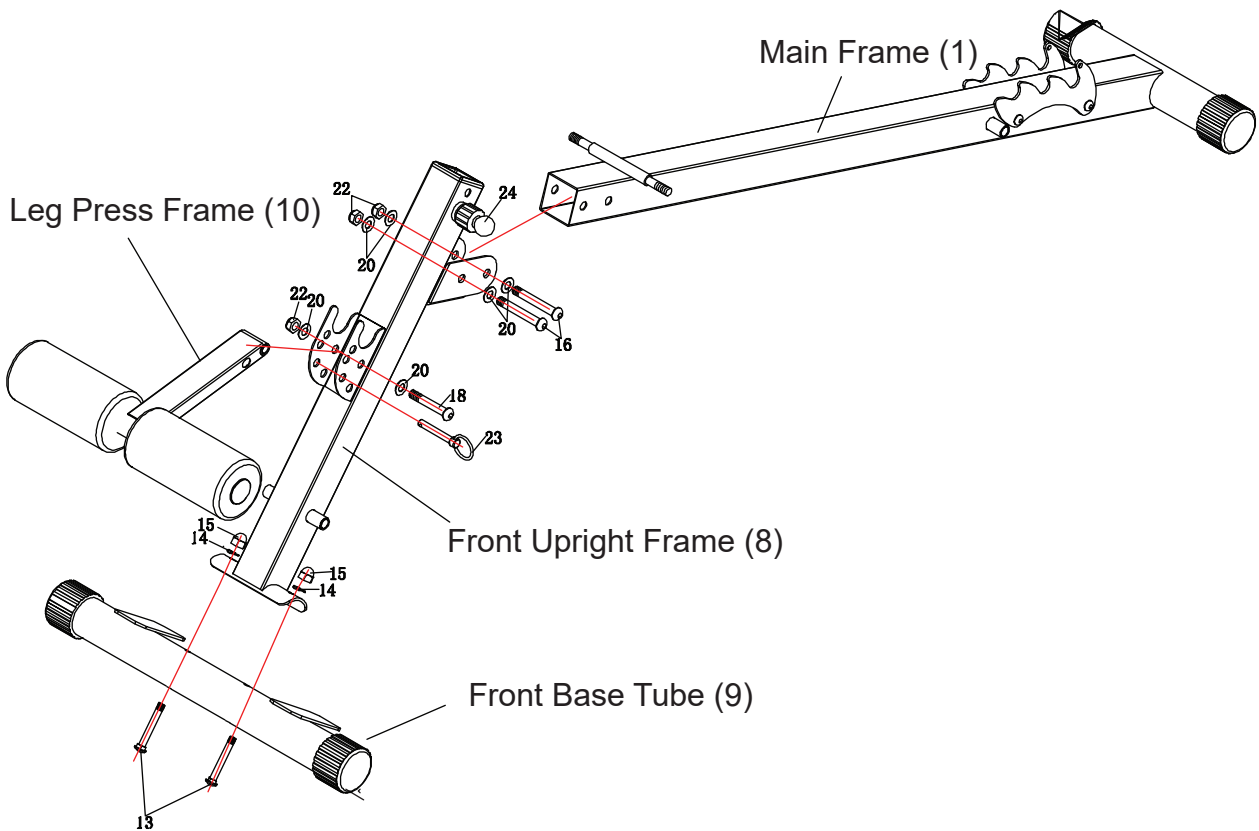

A) Fix the Front Base Tube (9) to the Front Upright Frame (8) with Carriage Bolts (13), Arc Washers (14) and Cap Nuts (15).

B) Connect the Front Upright Frame (8) and the Main Frame (1) with Internal Hex Cap Screws (16), Flat Washers (20) and Nylon Lock Nuts (22).

C) Install the Adjustment Knob (24) on the Front Upright Frame (8).

D) Fix the Leg Press Frame (10) to the Front Upright Frame (8) with Internal Hex Cap Screw (18), Flat Washers (20) and Nylon Lock Nut (22). Insert the Ball Lock Pin with Grip Handle (23) to the appropriate hole.

ⓘ If you find the Leg Press Frame difficult to move around, loosen Nylon Lock Nut (22) a little bit.

Step 2

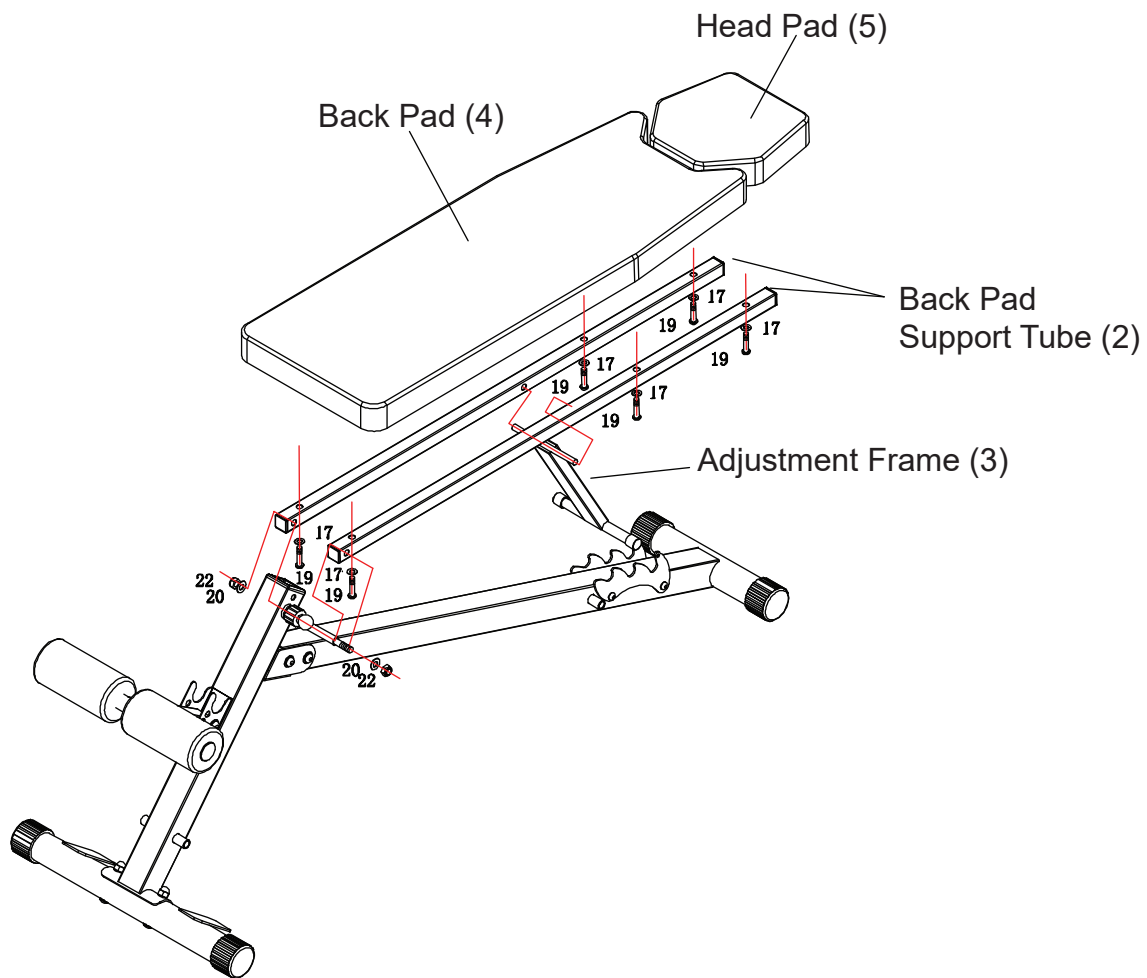

A) Attach the Back Pad Support Tubes (2) to the Main Frame (1) with Nylon Lock Nuts (22) and Flat Washers (20).

ⓘ Please note that the holes on the sides of the Back Pad Support Tubes (2) need to face inside.

B) Line up and fix the Adjustment Frame (3) to the Back Pad Support Tubes (2), through the holes on the sides of the Back Pad Support Tubes (2).

C) Fix the Back Pad (4) to the Back Pad Support Tubes (2) with Internal Hex Cap Screws (19) and Flat Washers (17).

Step 3

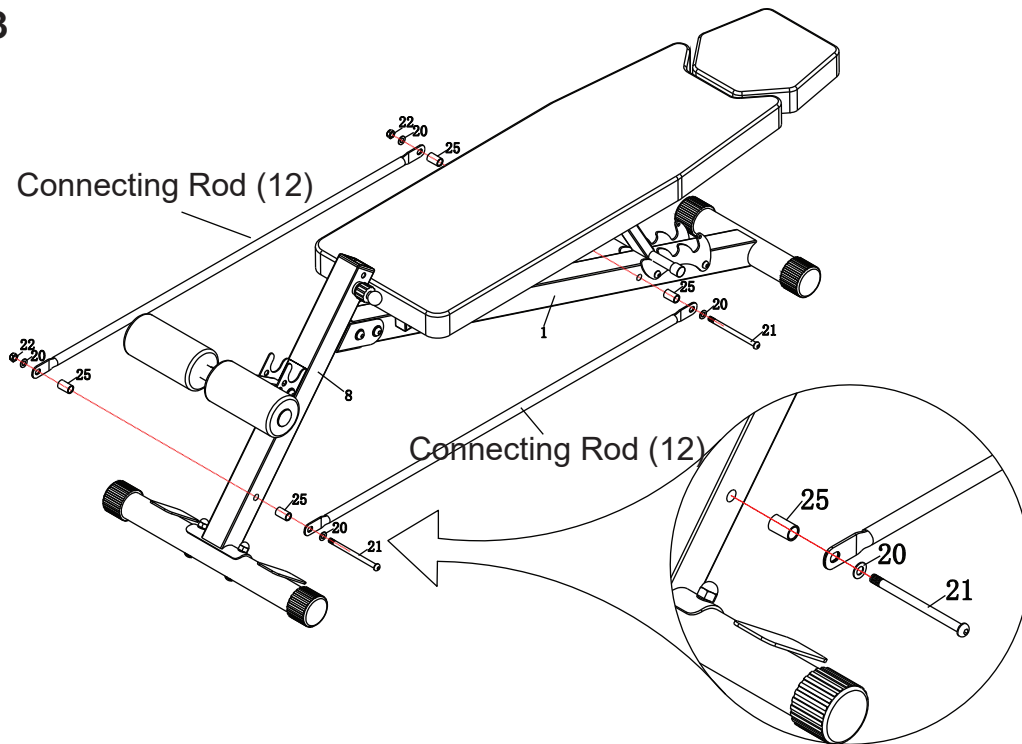

Fix the Connecting Rods (12) to the two sides of the Main Frame (1) and the Front Upright Frame (8) with Internal Hex Cap Screws (21), Plugs (25), Flat Washers (20) and Nylon Lock Nuts (22).

Step 4

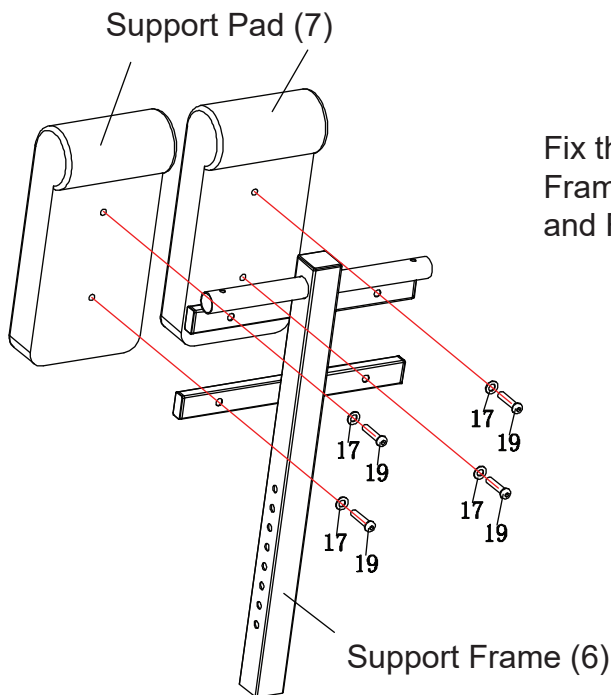

Fix the Support Pads (7) to the Support Frame (6) with Internal Hex Cap Screws (19) and Flat Washers (17).

Step 5

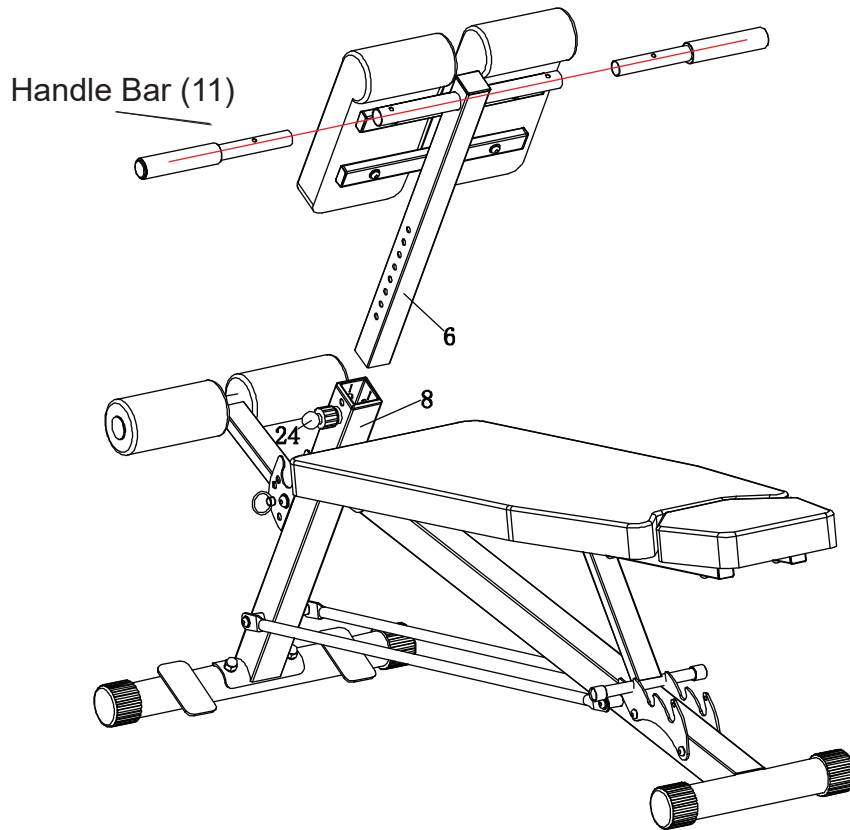

A) Loosen the Adjustment Knob (24), Insert the Support Frame (6) into the opening of the Front Upright Frame (8). Find a desired position and tighten the Adjustment Knob (24),

B) Insert the Handle Bars (11) to the Support Frame (6).

Congratulations. You're Finished!



If you find the bench wobbling or unbalanced, try the following fixes:

1. Loosen all screws, put some weight on the bench until it finds its own balance. Then, tighten screws again.
2. Tighten screws in Step 1 (B) and Step 2 (A)
3. The four rubber caps on the bench feet work as floor levelers. Rotate them to fit uneven surfaces.

LIMITED WARRANTY

Finer Form warrants that this product will be free from defects in materials and workmanship for One Year. This warranty is not transferable.

All Finer Form products are manufactured and tested with the highest quality standards and quality control processes. This warranty is limited to the non-commercial use of Finer Form products purchased in the United States.

Finer Form will not be liable for any loss or damage, including incidental or consequential damages of any kind, whether based upon warranty, contract or negligence, and arising in connection with the sale, use or repair of the product.

This warranty does not cover damage caused by accident (including in transit), repairs or attempted repairs by any person not authorized by Finer Form, or by vandalism, misuse, abuse, or alteration.

@Finer Form. All rights reserved.