



Installation Manual
Open Fender/Fender Flare
Product Number: TF4400 &
TF4410
Application: 2019 Dodge Ram HD



IMPORTANT SAFETY GUIDE | Your safety and the safety of others is very important.

In order to help you make informed decisions about safety, we have provided the following warnings, safety precautions, installation instructions, and other important information to alert you to potential hazards that could hurt you or others.

Please do a job safety analysis before each task to identify potential hazards for your situation and remove/protect against them. Use own good judgment and take your time.

Check packaged materials immediately upon arrival to ensure that all listed parts are included and undamaged.

READ AND UNDERSTAND ALL WARNINGS, SAFETY PRECAUTIONS, AND INSTRUCTIONS BEFORE INSTALLING THIS PRODUCT.

TIRE RUBBING MAY OCCUR AFTER INSTALLATION OF THIS PRODUCT.

WARNINGS

- Failure to observe the following warnings and instructions provided in this manual could lead to severe injury and/or death.
- For professional installation only. Careless installation and/or operation can result in serious injury, death, and/or equipment damage. All liability for installation and use rests with the user or consumer.
- Fab Fours, Inc. only approves installing this product according to these written instructions with the hardware provided. Failure to install according to these instructions will invalidate the warranty. This includes, but is not limited to, using alternative installation methods, hardware, or materials.
- This product is for off road use only.

SAFETY PRECAUTIONS

- Always remove jewelry and wear eye protection.
- Always use extreme caution when jacking up a vehicle for work. Set emergency brake and use tire blocks. Locate and use the vehicle manufacturers designated lifting points. Use jack stands.
- Always use appropriate and adequate care in lifting components into place.
- Always ensure components will remain secure during installation and operation.
- Always wear safety glasses when installing this kit. A drilling operation will cause flying metal chips. Flying chips can cause serious eye injury.
- Always use extreme caution when drilling a vehicle. Always disconnect power before welding. Thoroughly inspect the area to be drilled (on both sides of material when possible) prior to drilling, and relocate any objects that may be damaged.
- Always use extreme caution when welding a vehicle. Thoroughly inspect the area to be welded (on both sides of material when possible) prior to welding, and relocate any objects that may be a fire hazard. When welding in a cab, make sure the interior surfaces are covered (e.g., welding blanket) and a fire extinguisher is at hand.
- Always use extreme caution when cutting and trimming during fitting.
- Always tighten all nuts and bolts securely per installation instructions.
- Always route electrical cables carefully. Avoid moving parts, components that become hot, and rough or sharp edges.
- Always insulate and protect all exposed wiring and electrical terminals.
- Perform regular inspections and maintenance on mounts and hardware.

Table of contents

2	SAFETY / DISCLAIMER
3	TABLE OF CONTENTS
4	A MESSAGE FROM THE OWNER
5	GETTING STARTED
6	PROVIDED MATERIAL
9	CHAPTER 1: DISASSEMBLY
20	CHAPTER 2: TEMPLATE APPLICATION/CUTTING
37	CHAPTER 3: INSTALLATION/ ROCKER CHANNEL
43	CHAPTER 3: INSTALLATION/ FENDER BASES
52	CHAPTER 3: INSTALLATION/ INNER FENDERS
54	CHAPTER 3: INSTALLATION/ FENDER FLARES
59	CONTACT INFORMATION

A message from the owner



Fab Fours' was born out of a passion for customizing vehicles and a love for the outdoors. Our engineering team uses the latest 3D design software to turn new product ideas into reality. In our factory, designs come to life with the combination of cutting edge technology for metal cutting and forming and an American workforce that puts its' heart and pride into every product.

From design and manufacturing, to quality and delivery, Fab Fours' mission is to be the market leader for steel truck and jeep accessories. We make sure a quality product is delivered on time, more than expected, better than expected to our customers.

Enjoy your new Fab Fours product. Welcome to the family!

Greg Higgs

Founder, Fab Fours

Getting Started

Before you begin the installation process of your new Fab Fours product, we suggest laying out all materials and parts on a pad or protective surface.

Failure to fully account for all components before beginning installation may leave vehicle immobile until part is acquired. Refer to the next pages as an inventory check.



Instructional video

This manual is meant to be a comprehensive companion to online video resources.

Our goal is to provide this manual in bite-sized videos that an individual will feel comfortable using during the installation process.

Visit [youtube.com/FabFoursUSA](https://www.youtube.com/FabFoursUSA) for instructional videos.

Provided Materials



21351-02



21352-02

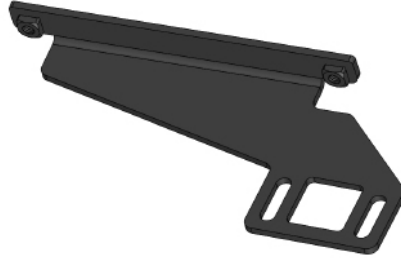

21402-01



21402-02



21402-03



21402-04

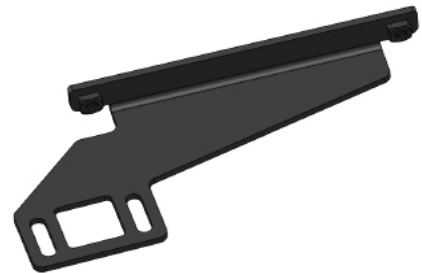

21403-01



21403-03



21403-04



21977-01

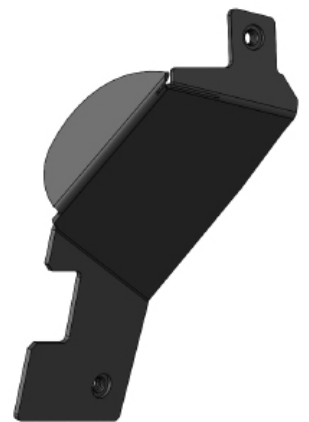

21978-01

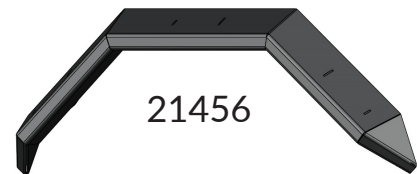
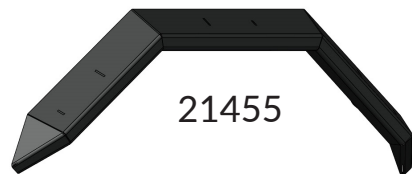
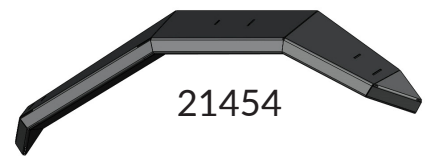
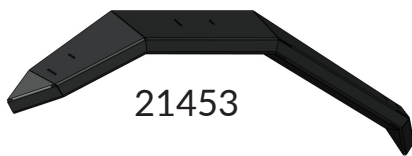
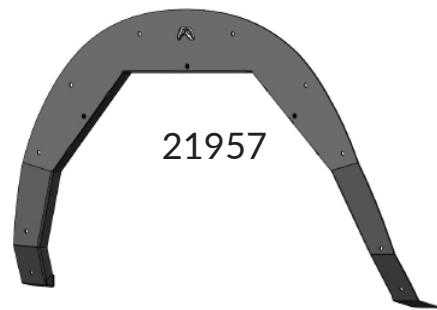
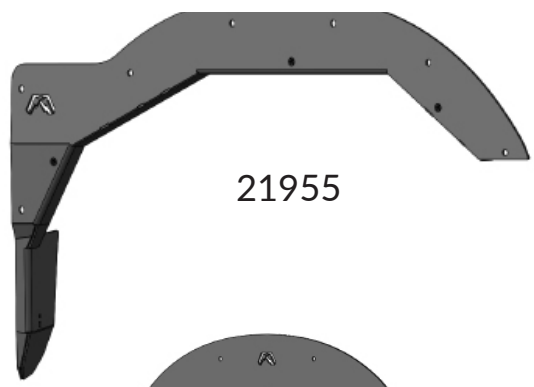

50192-HW

61729 SJ Leveling Kit

50121-HW

61728 Foam Seal Kit

TF4400-IM

61272 Rubber Seal x2

Hardware kit

Hardware Kit components		
HW Kit Number	Component Description	BOM Qty
50192-HW	5/16"-18 x 3/4",Stainless steel, Button head cap screw	34
50192-HW	5/16"-18 x 1.5",Stainless steel, Button head cap screw	22
50192-HW	5/16", Stainless steel, bonded sealing washer	56
50192-HW	5/16", Stainless steel, Flat washer	32
50192-HW	5/16", Stainless steel, Lock washer	32
50192-HW	5/16", Stainless steel, Hex nut	32
50192-HW	5/16"-18 x 1.0", Stainless steel, Self-tapping screw	8
50192-HW	5/16"-18 x 3/4", Grade 8, Yellow-zinc, Hex head cap screw	8
50192-HW	5/16",Grade 8, Yellow-zinc, USS, Flat washer, 7/8" OD	8
50192-HW	5/16", Grade 8, Yellow-zinc, Lock washer	8
50192-HW	5/16", Stainless steel, Fender washer	4
50192-HW	Loop clamp	2
50119-HW	5/16"-18 x 3/4", Grade 8, Yellow-zinc, Hex head cap screw	12
50119-HW	5/16", Grade 8, yellow-zinc, USS, Flat washer, 7/8" OD	12
50119-HW	5/16", Grade 8, Yellow-zinc, Lock washer	12

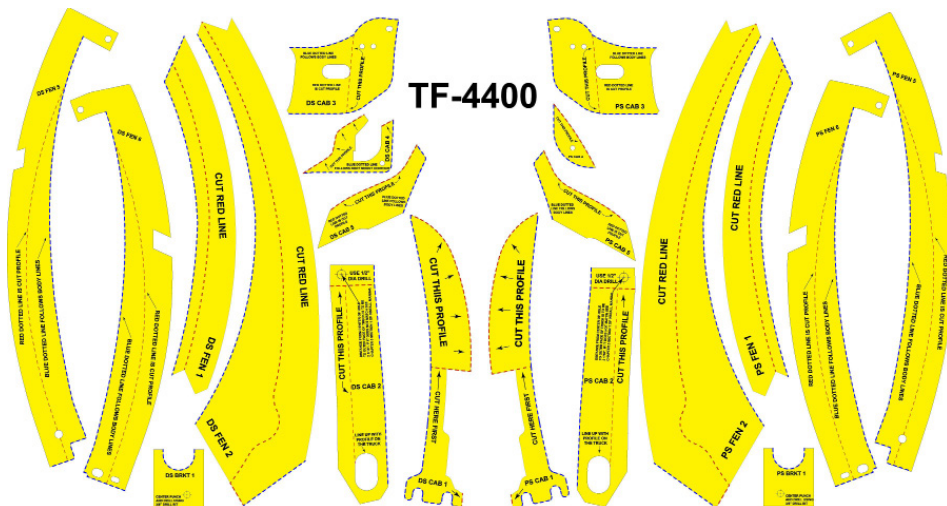

TOOLS REQUIRED

- 3-ton (or larger) jack
- 3-ton (or larger) jack stands (QTY 4)
- 8mm, 10mm, 18mm, 22mm, 24mm, 3/8", 1/2" socket wrenches
- 18mm & 1/2" open end wrenches
- 3/16" Allen wrench
- 25/64" Transfer Punch
- Hammer
- Plastic panel pry tool
- Painters tape
- Duct tape
- Black and silver sharpies
- Impact driver
- Large reciprocating saw
- Small reciprocating saw
- Angle grinder
- 4" flap disk wheel
- 4" cut off wheel
- Die grinder
- 2" cut off wheel
- Vise-grip C-Clamp (Qty 3)
- Anti-seize compound
- Deburring tool
- Razor blade

Disassembly

Disconnecting the battery terminals, removing the tires and raising the vehicle is recommended at this time. We recommend the use of an appropriately rated lift for the vehicle.

Begin the installation of this product with the Skyjacker leveling kit.

Organization

Disassemble the vehicle where you can catalog and store everything. We suggest labeling and bagging all the OEM bolts when removing from the vehicle. Failure to keep track of parts could lead to an inability to properly reinstall components.

Assistance

We recommend two people perform the disassembly.

We recommend protecting any painted surfaces that may come in contact with the work area with painters tape.

1. Using an appropriately rated vehicle jack and jack stands or an appropriately rated vehicle lift raise the vehicle so that the tires are off the ground.

2. Using a 22mm socket wrench remove the eight (8) lug nuts from each of the four (4) wheels and set the factory wheels and tires aside.

3. Disconnect the IBS sensor connection from sensor on the negative battery terminal. Figure 1

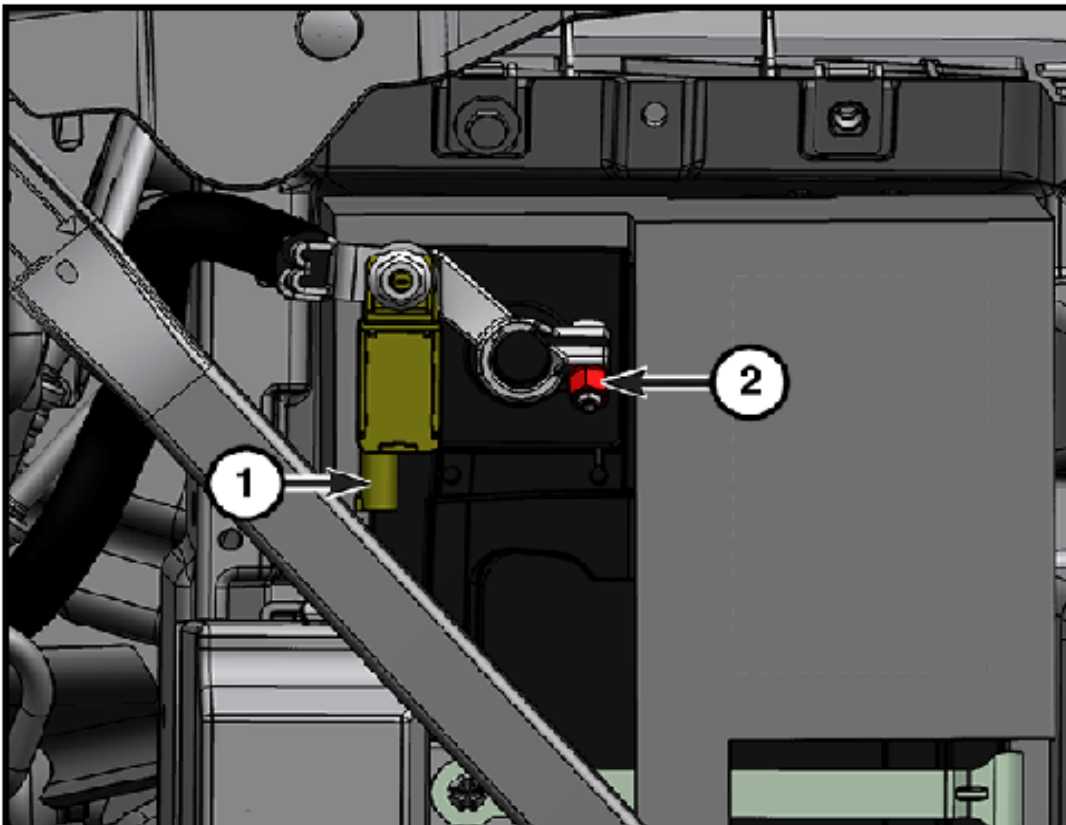

Figure 1

4. Using a 10mm socket wrench, disconnect the negative terminal from the battery. Figure 1, #2

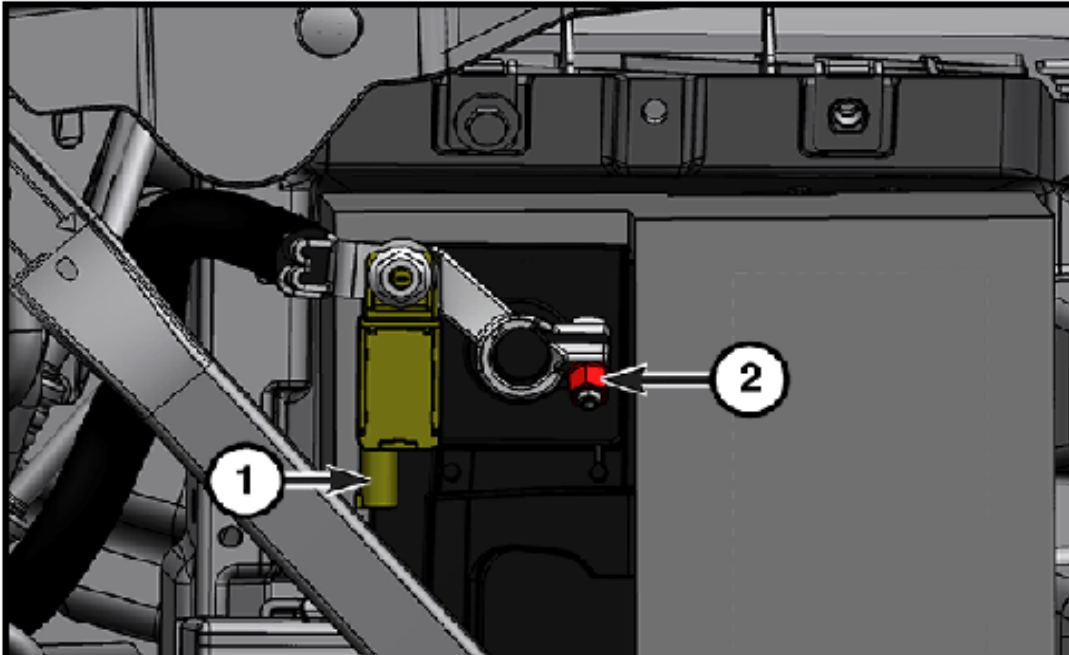

Figure 1, #2

5. If applicable, disconnect the negative terminal from the auxiliary battery. Figure 2

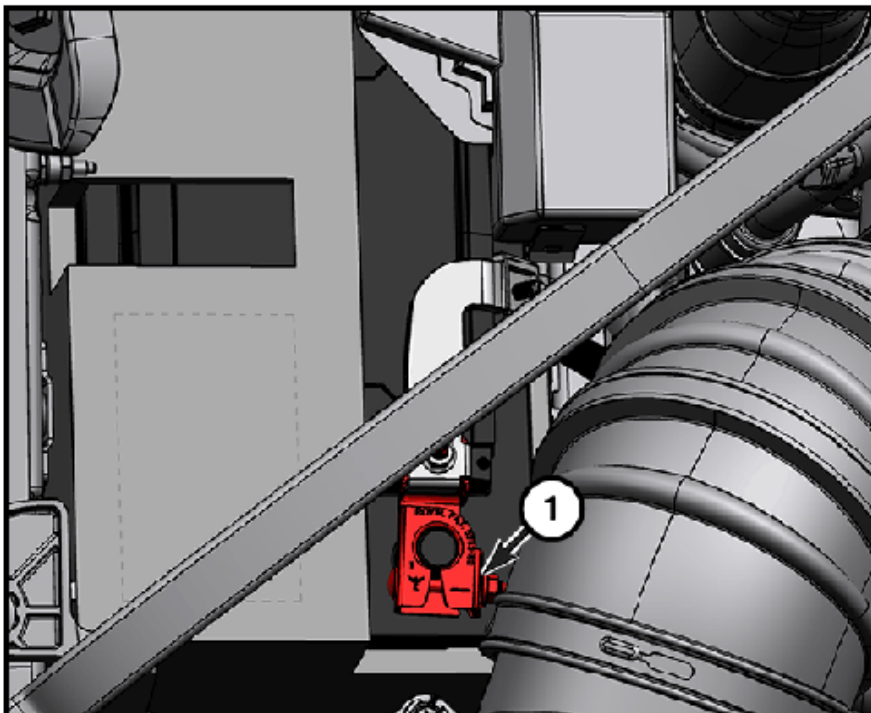

Figure 2

6. Using an 8mm socket wrench and plastic panel pry tool, remove the two (2) screws and one (1) push pin from the rear splash shield trim. Figure 3

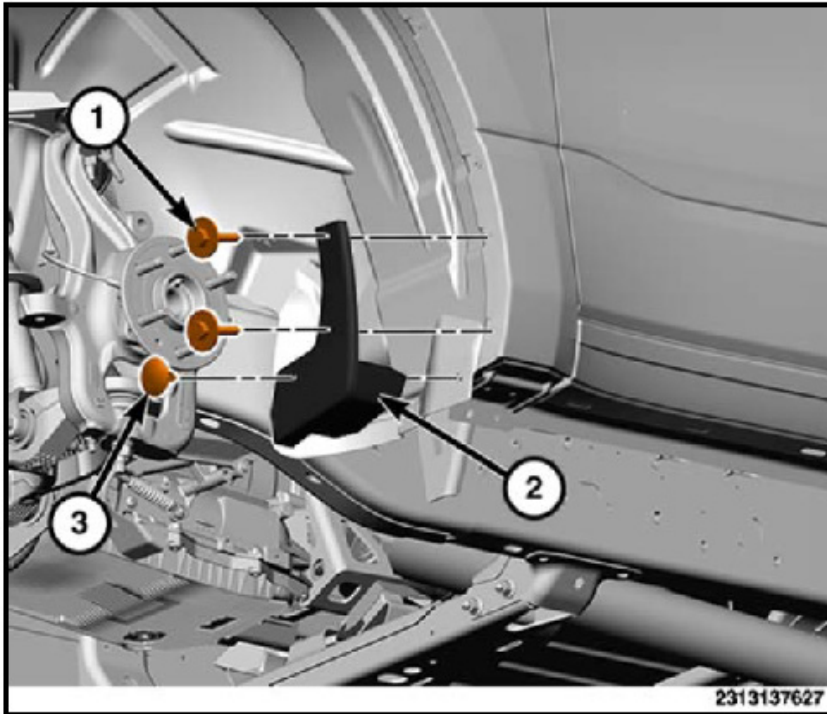

Figure 3

7. Using an 10mm socket wrench and plastic panel pry tool, remove the twelve (12) screws and two (2) push pins from the inner fender and set aside. Figure 4 & 5

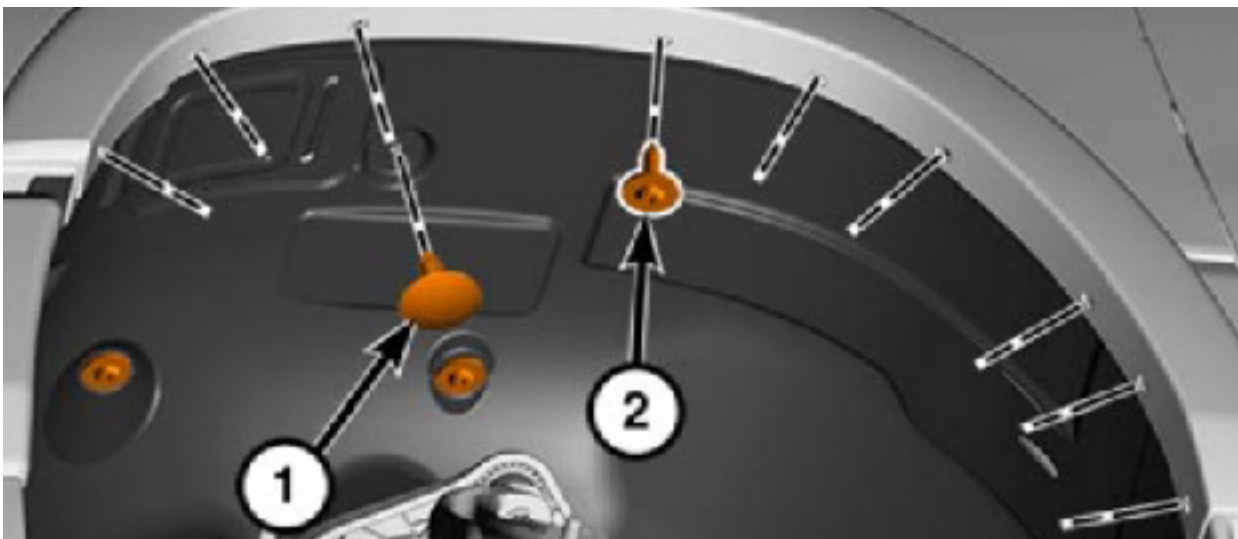

Figure 4

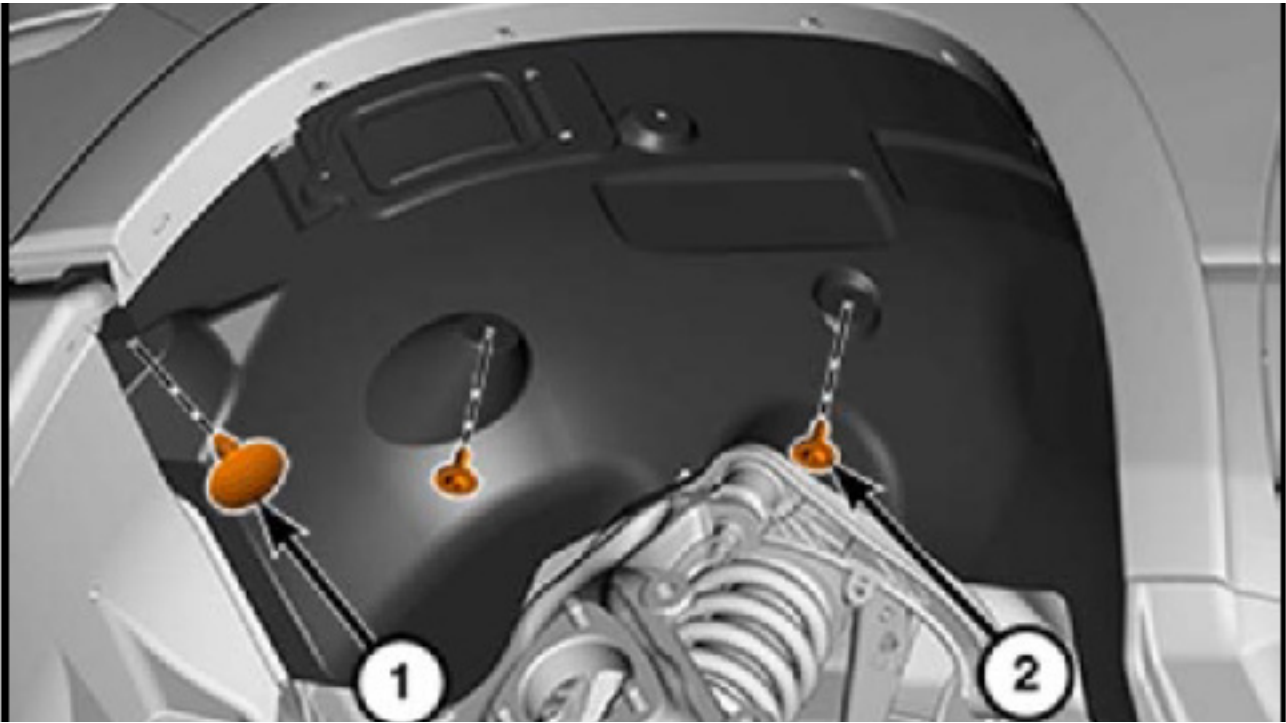

Figure 5

8. Disconnect the factory wiring harness from the inside of the driver side wheel well. Figure 6

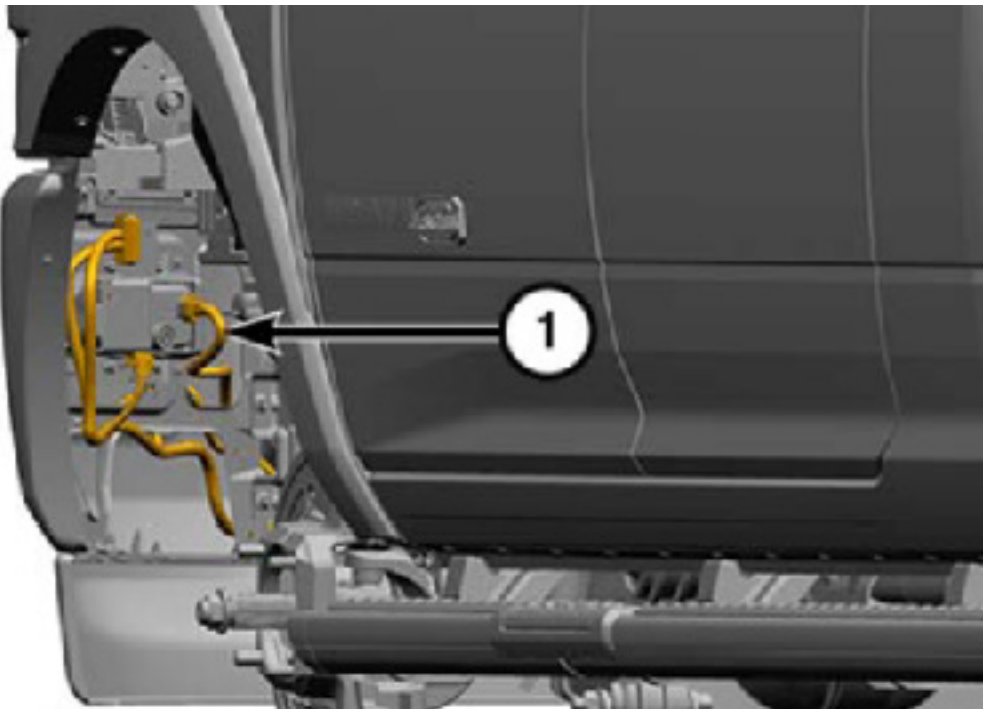

Figure 6

9. With assistance, support the bumper from both sides of the vehicle. Using an 18mm socket wrench, 24mm socket wrench and 18mm open end wrench, remove the three (3) factory bumper bolts that hold the factory bumper to the frame rail. Figure 7

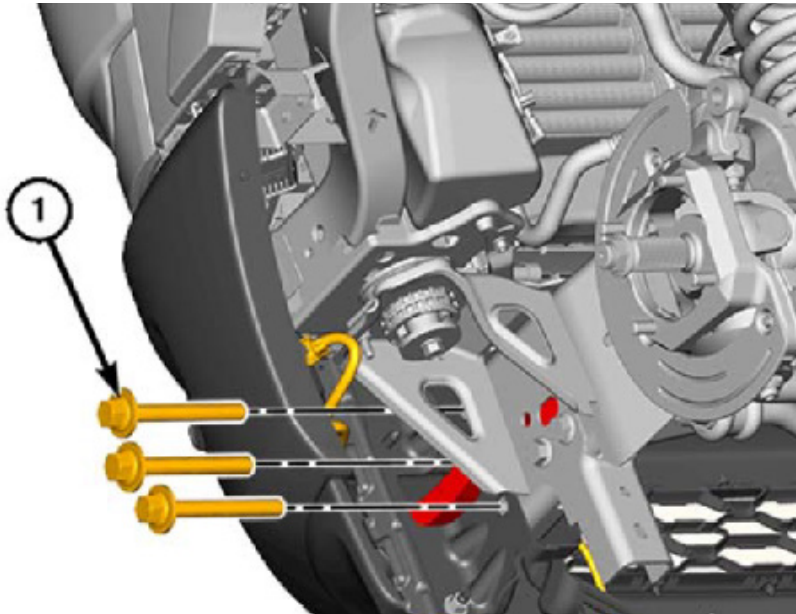

Figure 7

Note:

The factory tow hooks stay in the frame rail while extracting the front bumper from the frame rail ends.

10. Remove the factory bumper from the vehicle and set aside. Figure 8

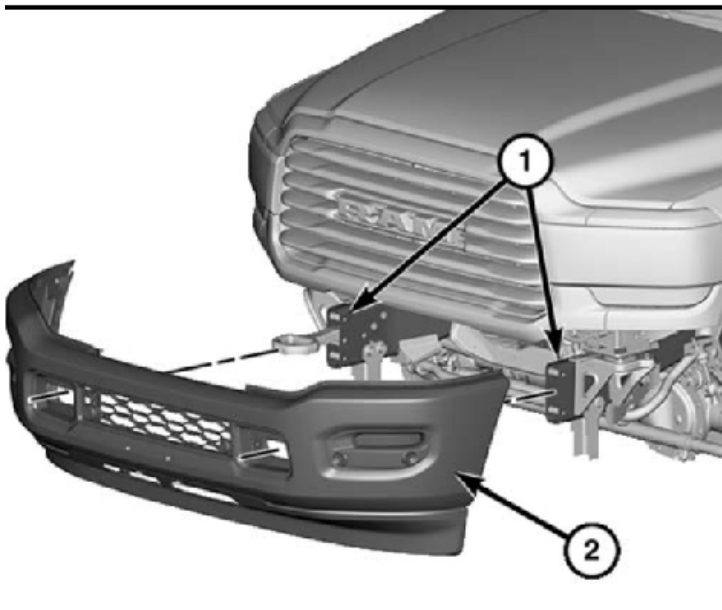

Figure 8

11. Using an 8mm socket wrench, remove the screw in the splash shield forward of the bed wheel well. Then using the plastic body panel pry tool, pull down and forward to remove the splash shield. Using the plastic panel pry tool remove all the plastic clips left in the bed. Figure 9 & 10



Figure 9



Figure 10

12. Using an 8mm socket wrench, remove the two (2) screws in the splash shield rearward of the bed wheel well. Then using the plastic body panel pry tool, pull down to remove the splash shield. Using the plastic panel pry tool remove all plastic clips left in the bed. Figure 11



Figure 11

13. Using an 8mm socket wrench, remove the four (4) screws attaching the forward rear inner fender to the bed and remove it. Figure 12

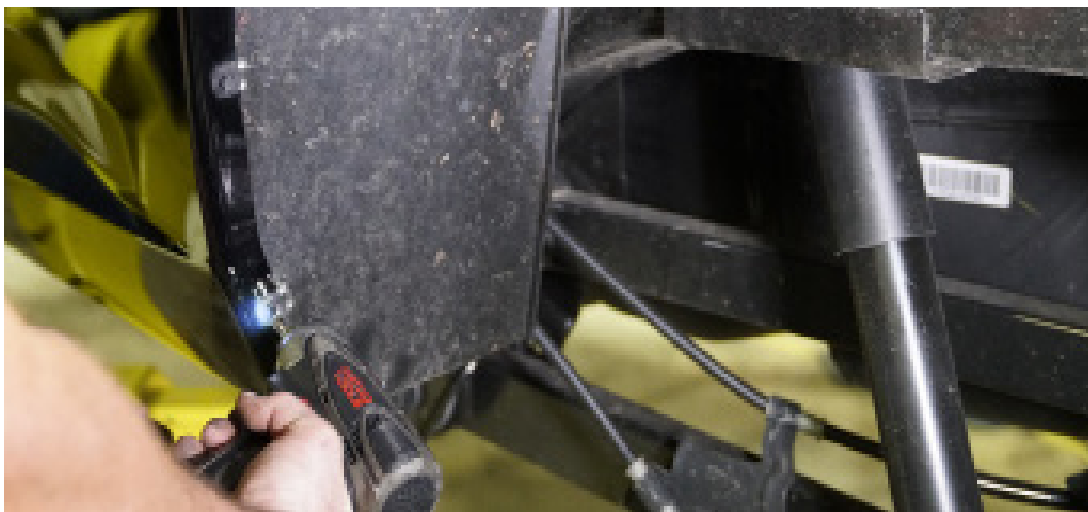

Figure 12

14. Using an 8mm socket wrench, remove the three (3) screws attaching the rearward rear inner fender to the bed and remove it. Figure 13



Figure 13

Note: There are two (2) versions of rear inner fenders available. If your vehicle has the one (1) piece version the process will be the same as explained in steps 13-14, but there will be additional screws to be removed.

15. Using a 10mm socket wrench, remove the two (2) screws at the bottom of the front fender. Figure 14



Figure 14

16. Remove the foam filler panel from the inside of the fender along the door hinges. Figure 15



Figure 15

17. Using a plastic panel pry tool, carefully remove the body harness connector in the front wheel well and secure it near the frame to keep it away from the cutting area. Figure 16



Figure 16

18. Using a 10mm socket wrench, remove the screw attaching the support bar to the bottom of the inner bedside forward of the rear wheel. Figure 17



Figure 17

19. Repeat steps 6-17 on the passenger side of the vehicle.

Template Application/Cutting

1. Using painters tape, apply at least three (3) layers of tape to the forward most part of the front door. Figure 1



Figure 1

2. Apply the DS FEN 1 template to drivers' side front fender by first aligning the front section with the blue dashed line to the bottom of the fender near the bumper. Then align the rounded blue dashed line area of the template with the wheel well edge. Finally finish applying the template by working the template upwards away from the wheel well opening. If small bubbles remain this is fine, it will not affect the functionality of the template. Figure 2-4

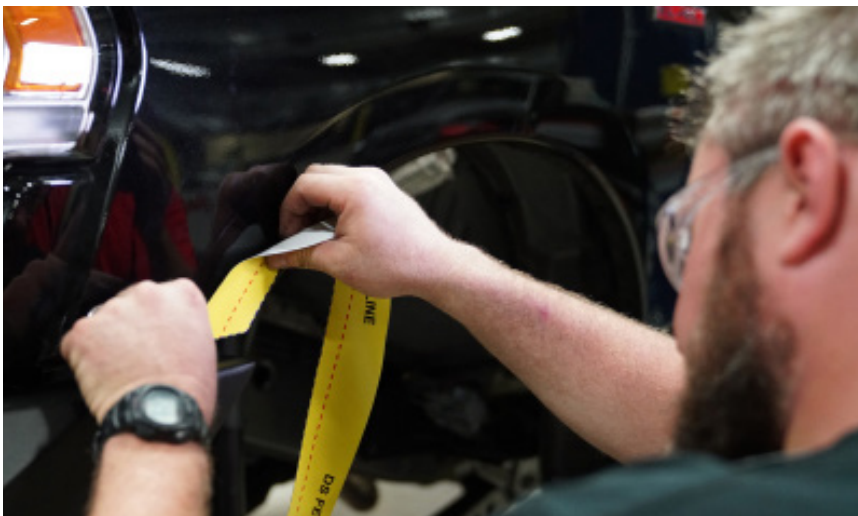

Figure 2

Organization

Disassemble the vehicle where you can catalog and store everything. We suggest labeling and bagging all the OEM bolts when removing from the vehicle. Failure to keep track of parts could lead to an inability to properly reinstall components.

Assistance

We recommend two people perform the cutting process.

We recommend protecting any painted surfaces that may come in contact with the work area with painters tape.



Figure 3

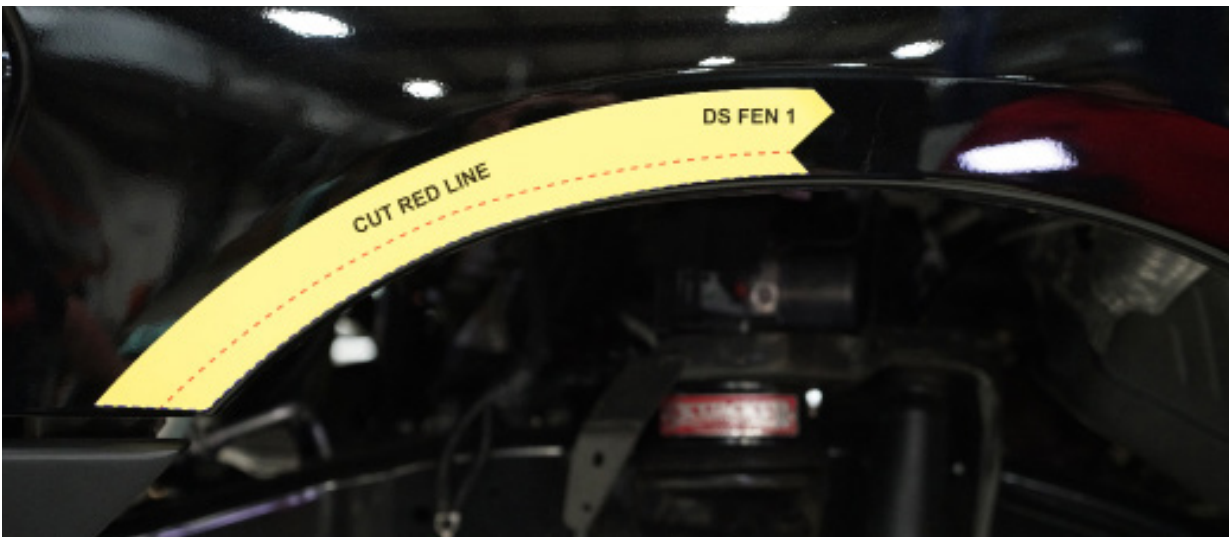

Figure 4

3. Apply the DS FEN 2 template to the driver's side front fender beginning with the puzzle piece section at the right side of DS FEN 1. Then work the blue dashed line along the wheel well opening continuing into the stamped body line running horizontal on the fender ending at the door jamb. Finish the application by working the template upwards away from the wheel opening. Figure 5-7



Figure 5



Figure 6



Figure 7

4. Apply the DS FEN 5 template to the bed along the forward edge of the wheel well. Begin by aligning the hole in the template with the hole left from removing the bolt that attaches the stiffener to the bed side. Then work the template edge with the dashed blue line along the wheel well opening until you reach the other hole in the template. Align this hole with the hole in the return flange of the wheel well. Finally, work the template away from the dashed blue line. Figure 8-10



Figure 8



Figure 9



Figure 10

5. Apply the DS FEN 6 template to the bed along the rearward edge of the wheel well. Begin by aligning the two (2) slotted cutouts in the bottom of the template with the slotted holes in the bottom of the bed side. Then align the blue dashed line with the wheel well edge towards the hole in the top of the template. Align the hole in the top of the template with the hole in the wheel well return flange. Finally, work the template away from the blue dashed line. Figure 11-12



Figure 11



Figure 12

6. Using a small reciprocating saw, cut along the red dashed line of the DS FEN 1 template. Then continue cutting onto the red dashed line of the DS FEN 2 template. Figure 13-14



Figure 13



Figure 14

7. Using a flap disk wheel on an angle grinder remove any sharp edges along the cut area. Figure 15



Figure 15

8. Using a small reciprocating saw, cut along the inside of the red dashed line of the DS FEN 5 template leaving the red dashed line on the vehicle when the cut is finished. Figure 16-17



Figure 16

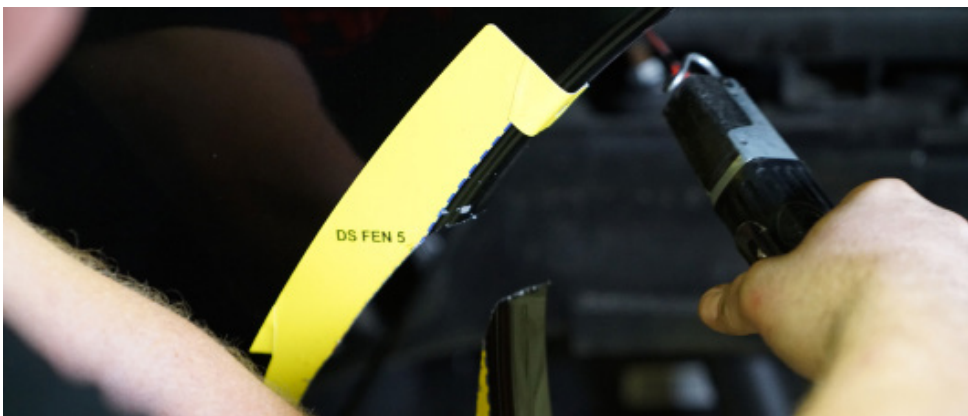

Figure 17

9. Using a small reciprocation saw, cut along the inside of the red dashed line of the DS FEN 6 template leaving the red dashed line on the vehicle when the cut is finished. Figure 18-19



Figure 18



Figure 19

10. Using a flap disk wheel on an angle grinder remove any sharp edges along the cut area. Figure 20



Figure 20

11. Remove all the templates now. Figure 21

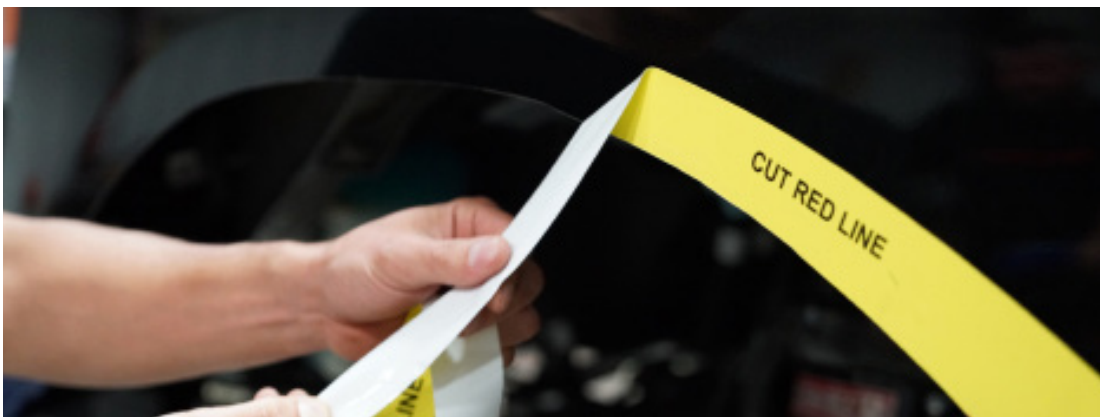

Figure 21

12. Apply the DS BRKT 1 template to the front inner structure tubing aligning the u-shaped cutout outlined with the blue dashed line on the template to the oval hole stamped in the vehicle. Figure 22



Figure 22

13. Using a 3/8" drill bit, make a hole in the indicated location on the DS BRKT 1 template. Then remove the template. Figure 23



Figure 23

14. Apply the DS CAB 1 template to the outside of the drivers' side rocker channel. Start by aligning the two (2) notches in the bottom of the template with the two (2) holes in the pinch weld. Then work the template upwards aligning the blue dashed line with the front profile of the rocker channel. Figure 24



Figure 24

15. Apply the DS CAB 2 template to the front face of the rocker channel starting with aligning the oval cutout in the template with the oval hole in the rocker channel. Then, work the template up the rocker channel aligning the blue dashed line with the corner of the outer edge of the rocker channel. Figure 25



Figure 25

16. Apply the DS CAB 3 template to the inboard side of the rocker channel using the slotted cutout in the template to align with the slotted hole in the rocker channel. Figure 26

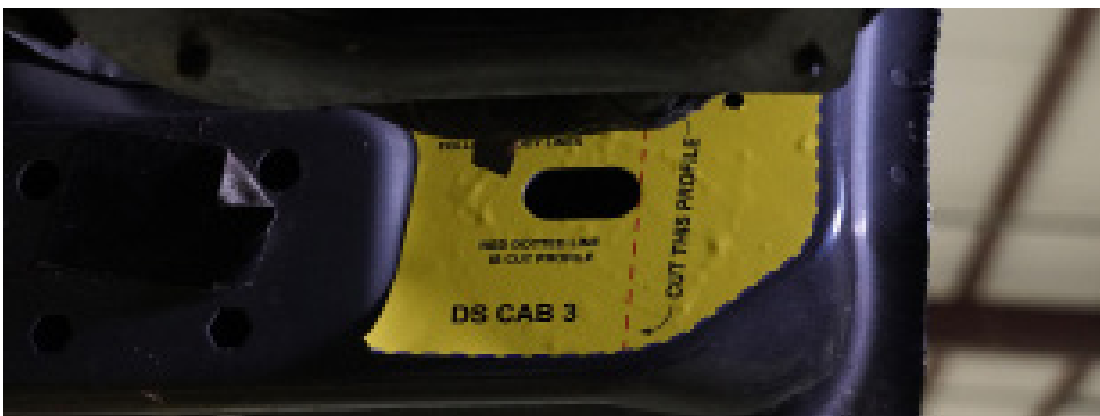

Figure 26

17. Apply the DS CAB 4 template to the drivers' side body mount on the frame aligning the blue dashed line profile with the outer edge of the body mount. Figure 27



Figure 27

18. Apply the DS CAB 5 template to the inboard side of the rocker channel above the DS CAB 3 template. Align the blue dashed line with the front edge of the rocker channel. Figure 28



Figure 28

19. Using a sharpie scribe a straight line on the outside of the rocker channel that connects the red dashed lines. Figure 29

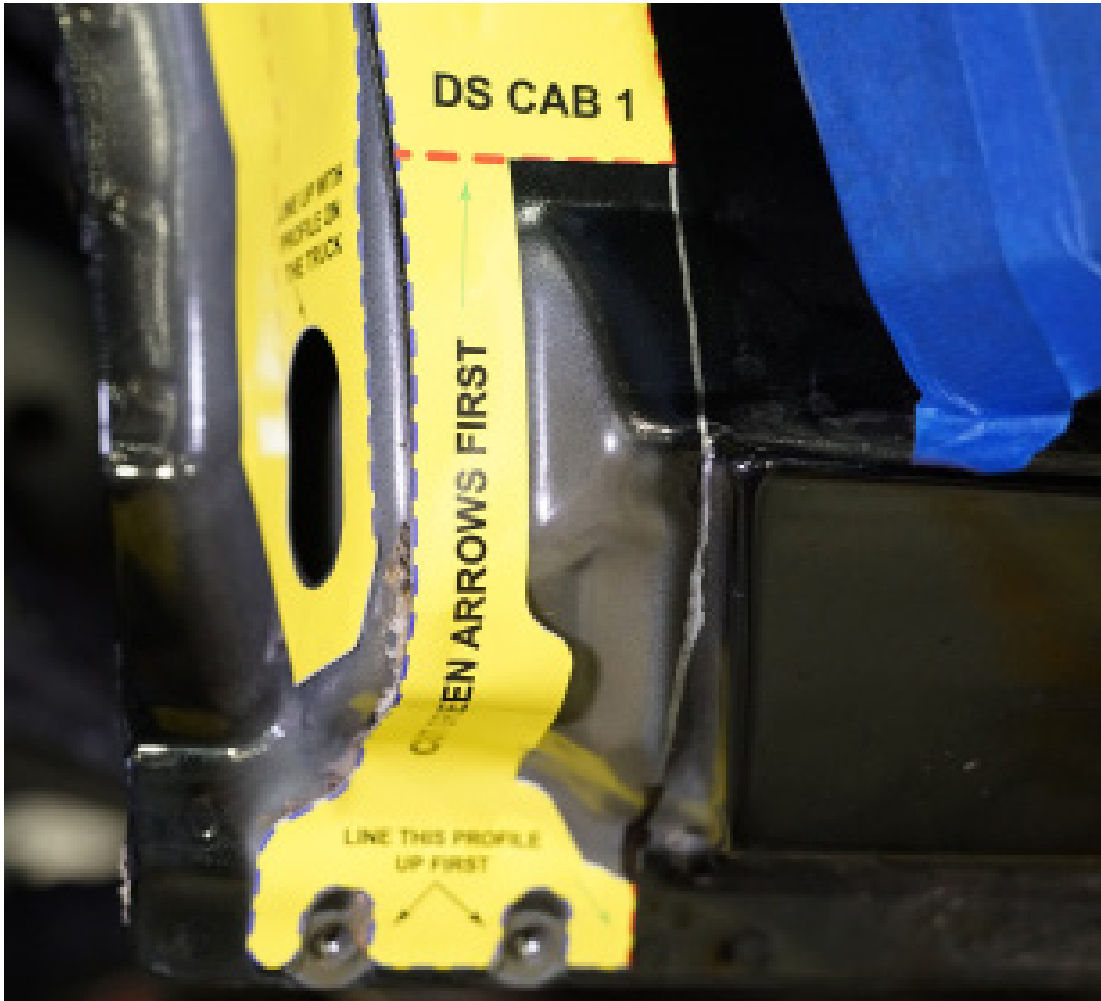

Figure 29

20. Using a large reciprocating saw, cut upward along the red dashed line of the DS CAB 1 template and previously made sharpie line until you reach the horizontal red dashed line. Cut horizontally through the rocker channel along the horizontal red dashed line until you reach the vertical cut. The corner of the rocker channel should disconnect. Figure 30-31

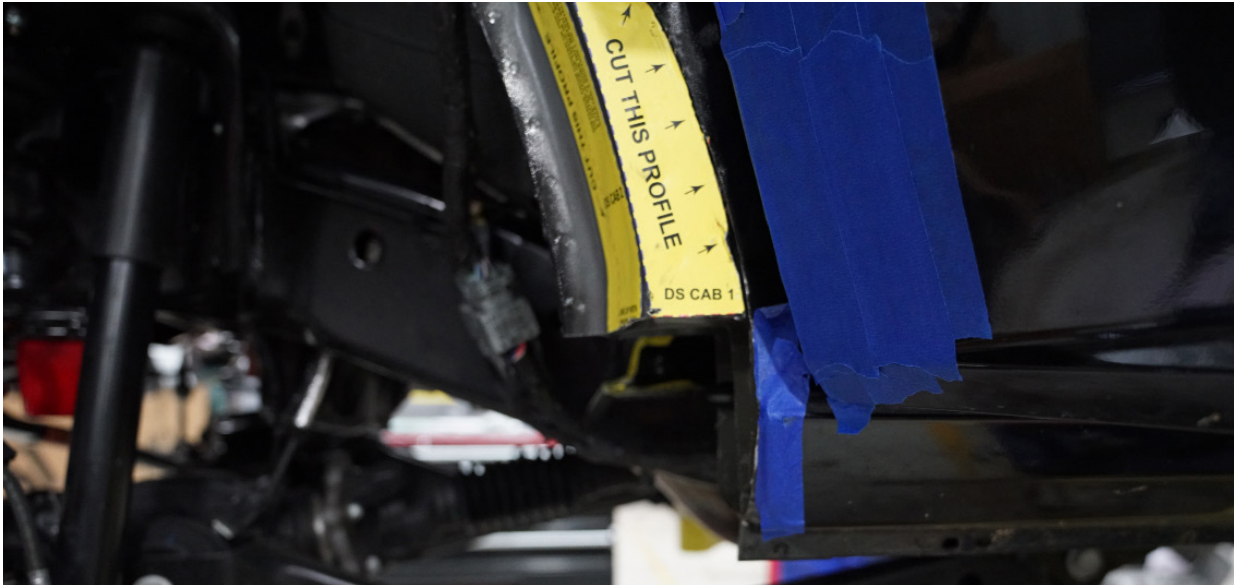

Figure 30



Figure 31

21. Using a small reciprocating saw, cut up along the red dashed line on DS CAB 1 and continue onto the horizontal red dashed line at the top of the DS CAB 2 template. Then cut up along the vertical dashed red line of the DS CAB 2 template to remove the rocker channel corner. Figure 32



Figure 32

22. Using a large reciprocating saw, cut the DS CAB 5 template into small sections horizontally. Do not cut past the red dashed line. Figure 33



Figure 33

23. Using a large reciprocating cut upward along the red dashed line of DS CAB 5 connecting the end of all the cuts made previously. Figure 34

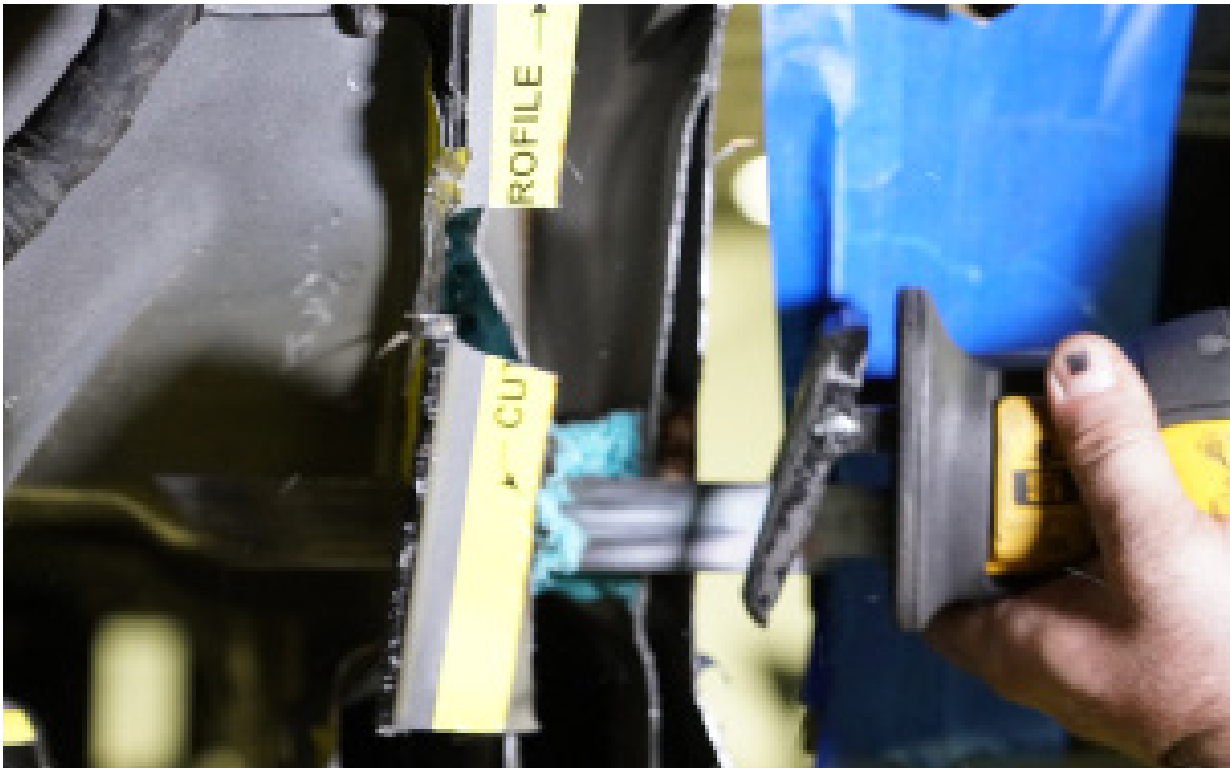

Figure 34

24. Using a large reciprocating saw, cut along the red dashed line of the DS CAB 4 template. Make sure the body control harness is clear before cutting. Figure 35



Figure 35

25. Using a small cutting wheel, remove the second layer from the outside of the rocker channel to allow clearance for the provided rocker channel cover plate. Figure 36



Figure 36

26. Using a flap disk wheel on an angle grinder, remove any sharp edges created from previous cutting operations.

27. Using the provided rust trap coating and paint brush, apply a liberal amount of paint to the bare metal created during cutting.

Installation | rocker channel plates

1. Using painters' tape, cover the front fender eight inches up from the cut area. Figure 1



Figure 1

2. Using a drill and 1/2" bit, make a hole indicated by the template above the cut area on the rocker channel. Figure 2-3



Figure 2



Figure 3

3. Loosely thread one (1) of the provided 5/16" stainless steel button head cap screws with bonded sealing washer (50192-HW) into the provided upper rocker channel cover plate (21977-01) through the previously drilled hole. The upper rocker channel cover plate should fit inside of the rocker channel. Figure 4



Figure 4

4. Loosely thread one (1) of the provided 5/16" stainless steel button head cap screws with bonded sealing washer (50192-HW) through the provided lower rocker channel cover plate (21351-02) slotted hole into the welded in nut on the upper rocker channel cover plate. Figure 5



Figure 5

5. Using an impact driver with a 3/8" socket, drill one (1) of the provided 5/16" self-tapping screws with bonded sealing washer (50192-HW) through the hole in the bottom of the lower rocker channel cover plate. Figure 6



Figure 6

6. Using a 3/16" Allen wrench, tighten the two (2) screws installed previously until the washer starts to flatten.

7. Place one (1) of the provided nut plates (21402-04) inside of the oval hole in the tubular structure inside of the fender. Figure 7



Figure 7

8. Loosely thread one (1) of the provided 5/16" grade 8 bolts, lock washers, and flat washers (50192-HW) through the provided horse-shoe shaped bracket (21402-02) into the previously installed nut plate. The nuts on the horse-shoe bracket should face up. Figure 8



Figure 8

9. Loosely thread two (2) of the provided 5/16" grade 8 bolts, lock washers, and flat washers (50192-HW) through the provided intermediate bracket (21402-01) into the previously horse-shoe bracket. Figure 9



Figure 9

10. Using duct tape, cover any gaps or hole that may exist between the rocker channel cover plates and the rocker channel itself. Figure 10



Figure 10

11. Using the provided foam sealant and dispensing gun (61725), fill the cavity in the rocker channel with one (1) entire tube of foam from a gap at the highest point. Keep pumping rapidly until the tubes are empty. If you stop pumping the mixing nozzle will harden and will no longer be useable. Figure 11



Figure 11

12. Give the foam sealant roughly five minutes to dry then use a razor blade to trim the excess away.
Figure 12



Figure 12

13. Using an impact driver and 3/8" socket, bundle the body wiring harnesses together in the provided loop clamp (50192-HW) and then attached the loop clamp to the backside of the rocker channel. Be sure to pull the connectors as far back under the cab as possible to keep the harness tight against the firewall away from the tire. Figure 13



Figure 13

Installation | Fender Bases

1. Apply the provided rubber edge trim (61727) to the outer perimeter of the four (4) fender bases. Do not stretch the trim during application or it will not stay in place. Start at one end of the fender base and use a razor blade to cut off the excess at the other end. Figure 1-3



Figure 1

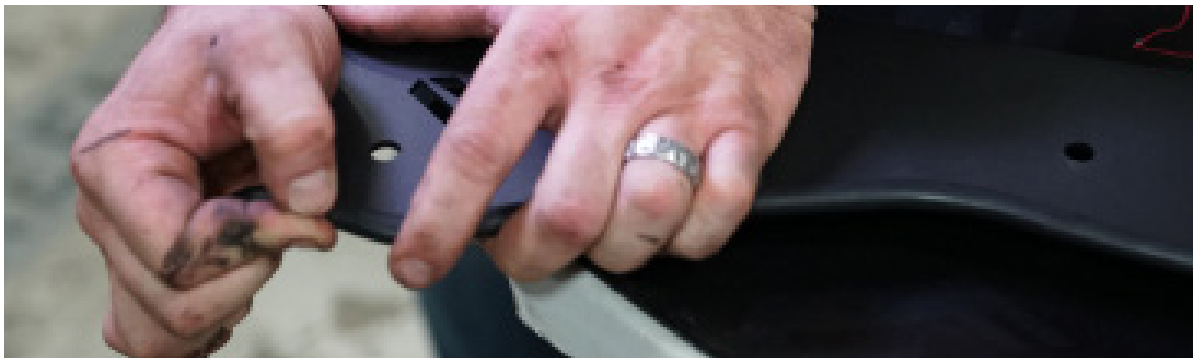

Figure 2

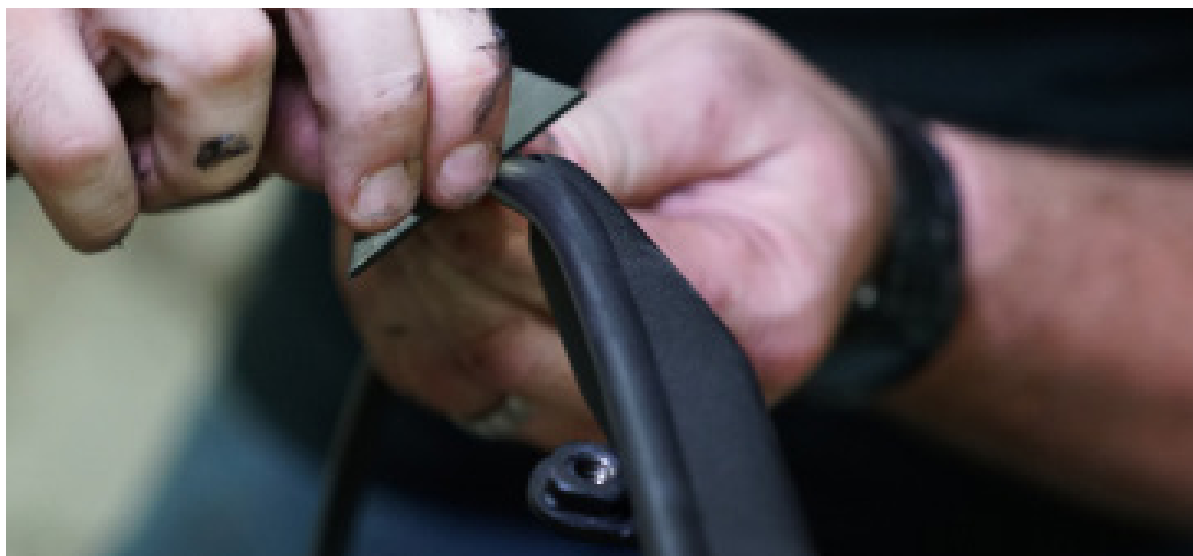

Figure 3

2. Using three (3) vise-grip c-clamps, hold the provided driver side front base (21954) up to the vehicle. Align the front edge with the bottom of the OEM fender below the headlight. Align the two (2) back to back bends below the farthest back hole with the profile on the door below the RAM logo. Figure 4



Figure 4

3. Using a 25/64" transfer punch and hammer, mark the seven (7) holes across the face of the driver side fender base. Figure 5



Figure 5

4. Remove the fender base from the vehicle and using a drill with 3/8" bit, drill out the seven (7) previously marked locations. Figure 6



Figure 6

5. Remove the painters' tape from the OEM fender.

6. Using a deburring tool, clean any sharp edges off the previously drilled holes in the OEM fender.

7. Using the provided rust trap coating and brush,(61725) apply a liberal coating to each drilled hole.

8. Loosely install the provided base fender support bracket (21402-03) to the nut tab at the lower portion of the base fender using one (1) of the provided 5/16"x1" grade 8 screws, flat washer, and lock washer (50192-HW). Figure 7



Figure 7

9. Using three (3) c-clamps, attach the provided fender base to the OEM fender again aligning it with the previously drilled holes. Figure 8



Figure 8

10. Using a 3/16" Allen wrench, 1/2" socket wrench, and seven (7) of the 5/16"x1" stainless steel button head caps screws with bonded sealing washers (50192-HW), install the provided fender base to the OEM fender for the final time. The two (2) center hole locations will thread into the previously installed intermediate bracket with weld nuts. The remaining five (5) locations will get a stainless steel flat and lock washer with a nut. Figure 9



Figure 9

11. Using a 3/16" Allen wrench and one (1) of the provided stainless steel 5/16"x1" button head cap screws with bonded sealing washer (50192-HW), connect the fender base support bracket to the lower rocker channel cover plate. Figure 10



Figure 10

12. Using a 3/16" Allen wrench and three (3) of the provided 5/16"x1" stainless steel button head cap screws with bonded sealing washers, fill the remaining three (3) holes in the base fender that have welded in nuts. Figure 11



Figure 11

13. Using a 1/2" socket wrench, tighten all the grade 8 hardware installed previously in the base fender support bracket.

14. Using painters' tape, cover the bed side 10" around the wheel well.

15. Using three (3) vise grip c-clamps, mount the provided drivers' rear base fender (21956) to the drivers' side of the bed. Figure 12

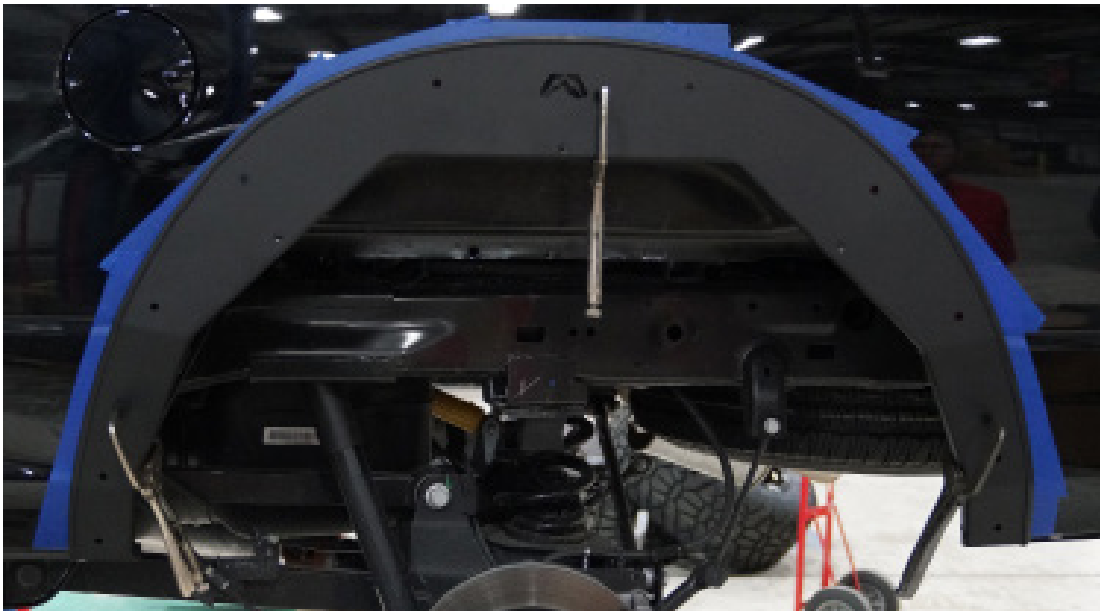

Figure 12

16. Using a 25/64" transfer punch and hammer, mark the 10 holes across the face of the base fender. Figure 13



Figure 13

17. Remove the base fender from the vehicle and using a drill with 3/8" bit, drill out the 10 previously marked holes. Figure 14



Figure 14

18. Using a deburring tool, clean out any sharp edges in the previously drilled holes.

19. Using the provided rust trap coating and brush, (61725) apply a liberal amount to each of the previously drilled holes in the bed side. Figure 15

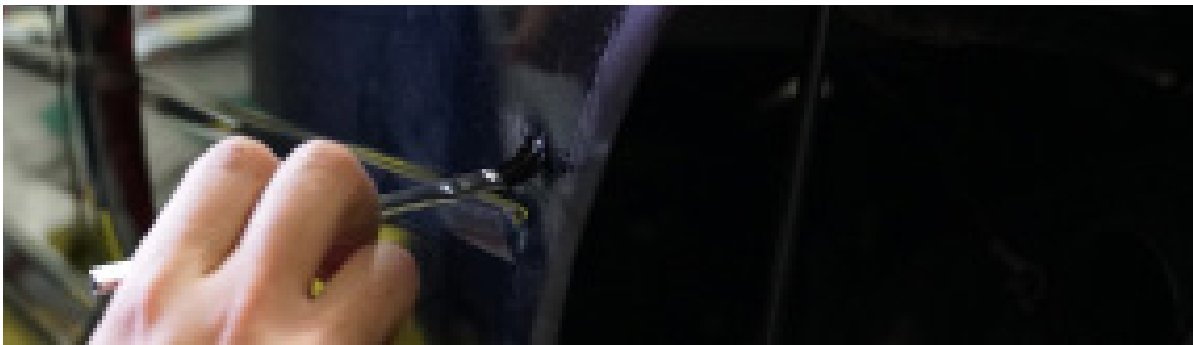

Figure 15

20. Using three (3) vise grip c-clamps, reinstall the base fender onto the bed side aligning the holes with the previously drilled holes. Figure 16



Figure 16

21. Using a 3/16" Allen wrench and 10 of the provided 5/16"x1.5" stainless steel button head cap screws with bonded sealing washers, flat washers, lock washers, and nuts (50192-HW) through the previously drilled holes. Figure 17

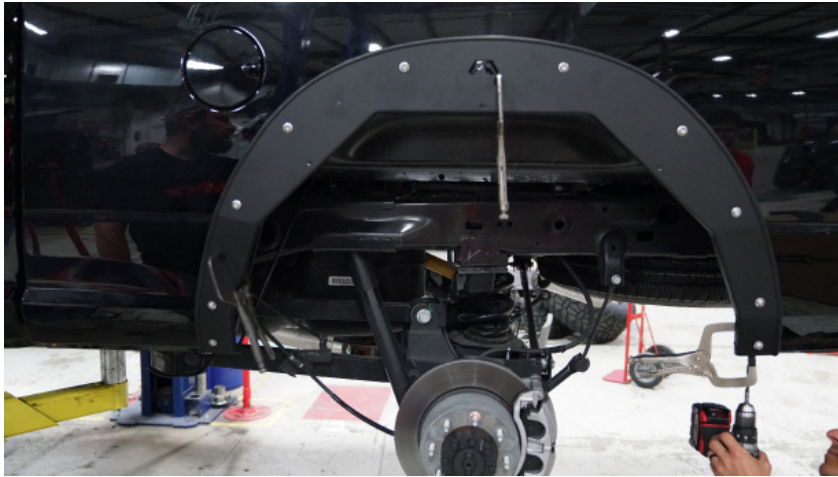

Figure 17

22. Using a 10mm socket wrench, reinstall the OEM screw removed from the bed stiffener bar previously. Use this screw to connect the bed stiffener bar to the provided base fender. Figure 18

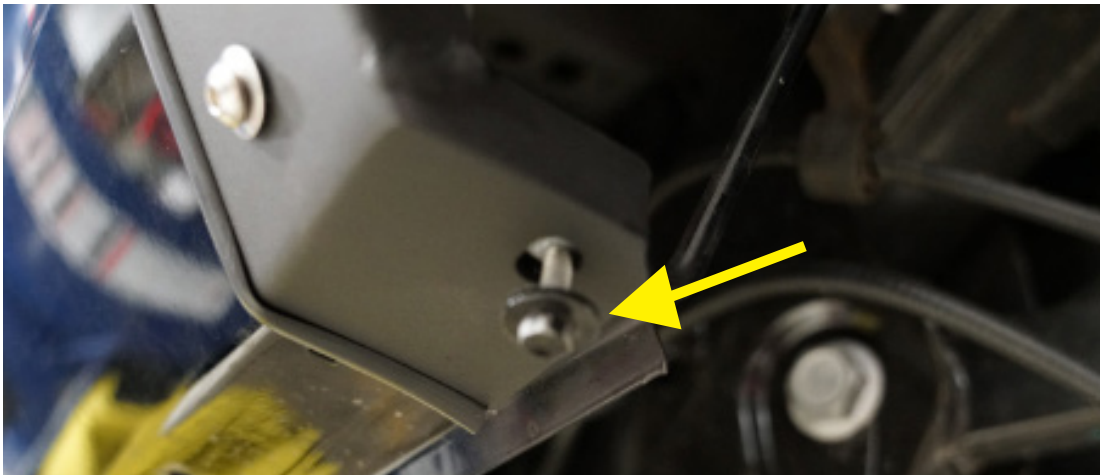

Figure 18

23. Using a 3/16" Allen wrench and 1/2" socket wrench. Install one (1) of the provided 5/16"x1.5" stainless steel hex head cap screws, bonded sealing washer, flat washer, lock washer, and nut in the bottom most rear hole in the provided base fender. This should line up with an existing hole in the OEM bedside. Figure 19



Figure 19

24. Using a 3/16" Allen wrench, install three (3) of the provided 5/16"x1" stainless steel button head cap screws with bonded sealing washers in the three (3) remaining holes with welded in nuts on the base fender. Figure 20



Figure 20

Installation | Inner Fenders

1. The front OEM inner fenders can be reused with a little modification. Using a small reciprocating saw the plastic can be cut. The profile of the cut can be field determined based on the choice of front bumper, tire size, and lift options. A suggested cut profile has been included. Figure 1



Figure 1

2. Four (4) 5/16" stainless steel self-tapping screws and stainless steel fender washers (50192-HW) have been provided to aid in the reinstallation of the driver and passenger sides. There are two (2) holes per side that had a ribbed shank push pin from the factory which the self-tapping screws can be installed using an impact driver with 3/8" socket. Figure 2-3



Figure 2



Figure 3

3. Finish reinstalling the modified inner fenders using an 8mm socket wrench to install the two (2) OEM screws and one (1) ribbed shank push pin. Figure 4



Figure 4

Installation | Fender Flares

1. Apply the provided rubber edge trim (61727) to the outer profile of the four (4) provided fender flares (21453-21456) by starting at one end and working it across to the opposite end. Then use a razor blade to trim off the excess. Figure 1-2



Figure 1



Figure 2

2. Using a 3/16" Allen wrench, remove the three (3) stainless steel button head cap screws per base fender installed previously in preparation for the fender flare hardware.

3. Using a 1/2" open end wrench, install the provided driver's side front fender flare (21453) with three (3) of the provided 5/16"x1" grade 8 screws, flat washers, and lock washers. Figure 3-4



Figure 3



Figure 4

4. Using a 1/2" open end wrench, install the provided driver's side rear fender flare (21455) with three (3) of the provided 5/16"x1" grade 8 screws, flat washers, and lock washers. (50192-HW) Figure 5



Figure 5

5. Repeat steps 2-3 on passenger side.

Congratulations!

You have completed the installation of the Fab Fours Open Fender Kit. We hope you enjoy your product and again, welcome to the family!



This page was intentionally left blank.

Contact Information

Fab Fours Inc.
2213 Industrial Park Road
Lancaster, SC 29720

Phone: (866) 385-1905

Fax: 866-574-1423

Email: support@fabfours.com

www.fabfours.com



“If you’re looking for more of the same,
Then you’ve come to the wrong place.”

- Greg Higgs

