

S6033

11-UP CHEV/GMC 2500/3500 DURAMAX DP
BACK 4" SINGLE SIDE DUAL OUTLET

MBRP
INC.
PERFORMANCE EXHAUST

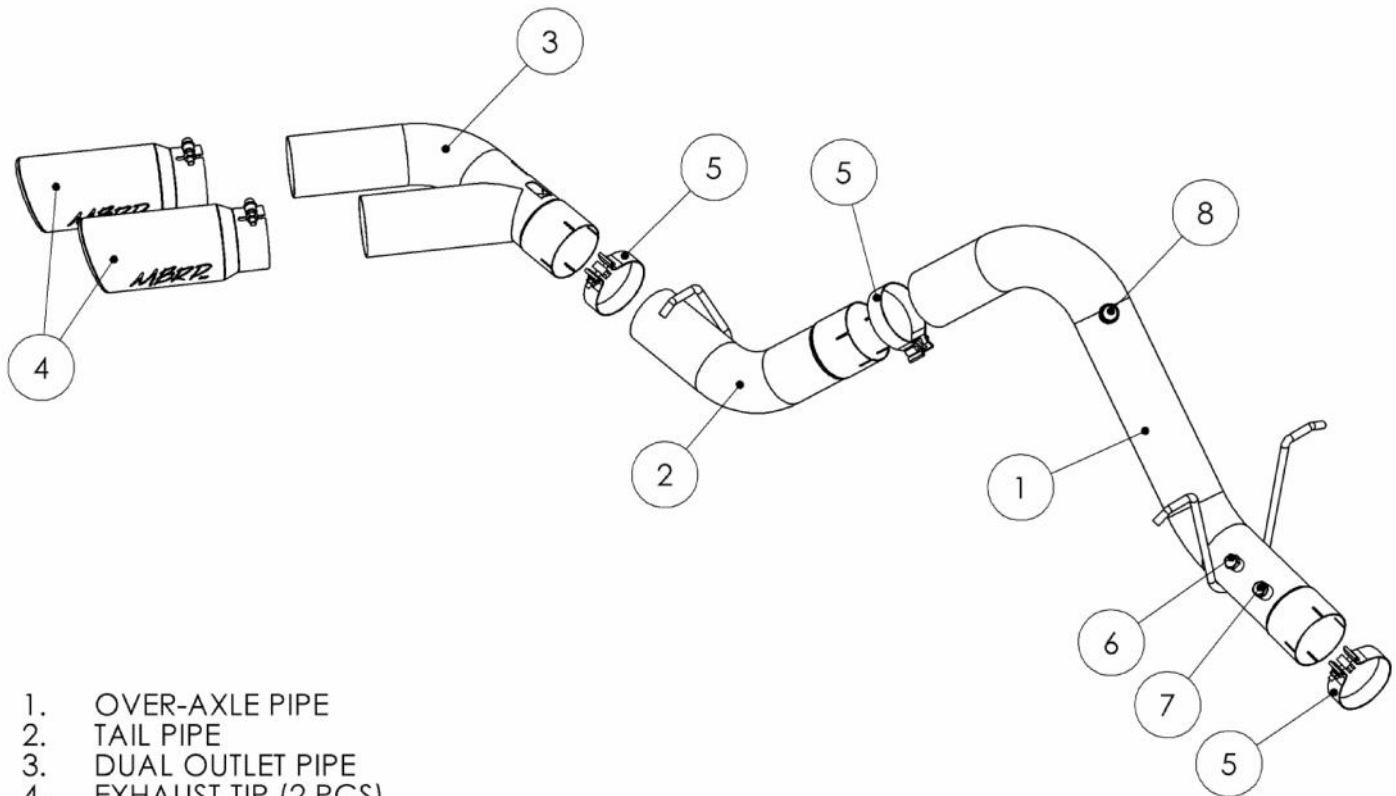

1. OVER-AXLE PIPE
2. TAIL PIPE
3. DUAL OUTLET PIPE
4. EXHAUST TIP (2 PCS)
5. CLAMP (3 PCS)
6. M14 PLUG
7. M16 PLUG
8. M22 PLUG

PLEASE READ BEFORE STARTING INSTALLATION

While MBRP Inc. has made every effort to ensure that all components of this system are of superior quality and properly packaged, it is the installer's responsibility to ensure the following before removal of the factory exhaust:

- that ALL components shown above are present.
- that ALL mating components fit together.
- that there are no damaged components.
- that the system you have purchased is appropriate for your vehicle year, model and configuration.
- that the system will not interfere with any modifications previously installed or planned.
- that you have read and understand these instructions.

If you have any questions or are uncertain about any aspect of the installation of this system to your vehicle please contact your dealer before commencing installation.

Removal of Stock System

1. Apply a penetrating lubricant liberally to all hangers and rubber insulators.
2. Mark a cut line 2.75" for 2011-2016 models, 5.375" for 2017+ models in front of the hanger in front of the rear axle on the factory system.

Refer to Figure 1 on last page.

3. Verify the cut line. It should be approximately 24" for 2011-2016 models, 24.5" for 2017+ models from the front of the axle tube. You can also leave the factory pipe *long and line up* the supplied **Over-Axle Pipe** expansion before making the final cut. Cut the factory pipe at the cut line.

Refer to Figure 2.

4. Disconnect and remove any sensors located in the section of the factory exhaust being removed. Retain these sensors as they will be reused. Note; sensors are on 2016+ trucks only.

5. Unhook the three factory rubber insulators from the exhaust and remove the factory pipe.



Figure 2



Figure 3



Figure 4

Installation of MBRP Inc. Performance Exhaust

1. Place a **Clamp** over the factory extension pipe and install the **Over-Axle Pipe** over the factory extension pipe.

Refer to Figure 3.

2. Install the **Over-Axle Pipe** hangers into the factory rubber hangers.

3. Place a **Clamp** on the inlet of the **Tailpipe** and install it onto the **Over-Axle Pipe**.

4. Install **Tailpipe** hanger into factory rubber hanger.

5. Place a **Clamp** on the Inlet of the **Dual Outlet Pipe** and install it onto the **Tailpipe**. Snug, but do not completely tighten all **Clamps**.

Refer to Figure 4.

6. Install the **Exhaust Tips** and adjust to your liking. The **Exhaust Tips** can only be installed on the straight sections of the **Dual Outlet Pipe**. Attempting to force them back farther may not allow them to tighten and align properly.

Refer to Figures 5 and 6.

NOTE: A 2015 Fleetside model is shown; other models may require a slight downward tilt of the Tail Pipe to provide adequate clearance from the Exhaust Tips to the body.

7. Once everything is aligned completely tighten all **Clamps**.

8. Remove threaded Plugs in **Over-Axle Pipe** and Reinstall any sensors previously removed. Note, 2011-15 trucks use no sensors, 2016 uses one sensor, 2017+ uses 3 sensors.

9. Check along the whole length of the exhaust system to ensure that there is adequate clearance around the spare tire, fuel and brake lines or any wiring. If any interference is detected relocate or adjust.

10. It is recommended to tack weld each joint, including the **Exhaust Tips** to ensure vibrations do not allow any pieces to become detached.

Congratulations! You are ready to begin experiencing the improved power, sound and driving experience of your *MBRP Inc.* performance exhaust system. We know you will enjoy your purchase.

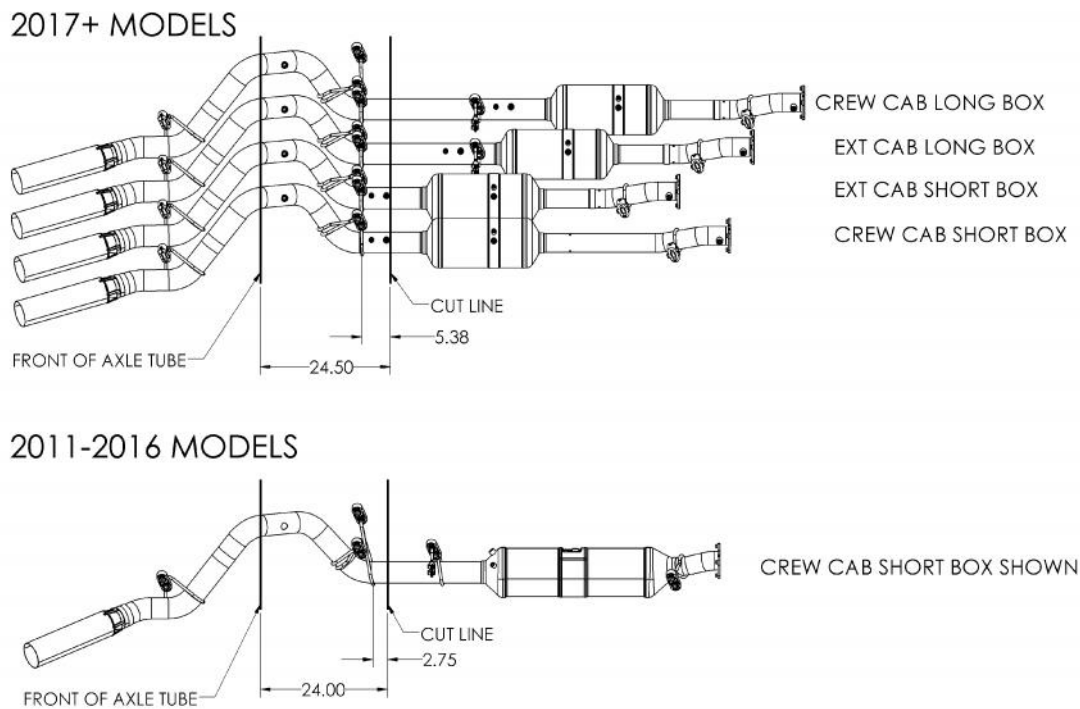

Figure 1