

# Installation Manual

**PACBRAKE®**

www.pacbrake.com 800.663.0096



**HP10019 KIT**



*Universal AMP Air Suspension Kit*



## KIT CONTENTS

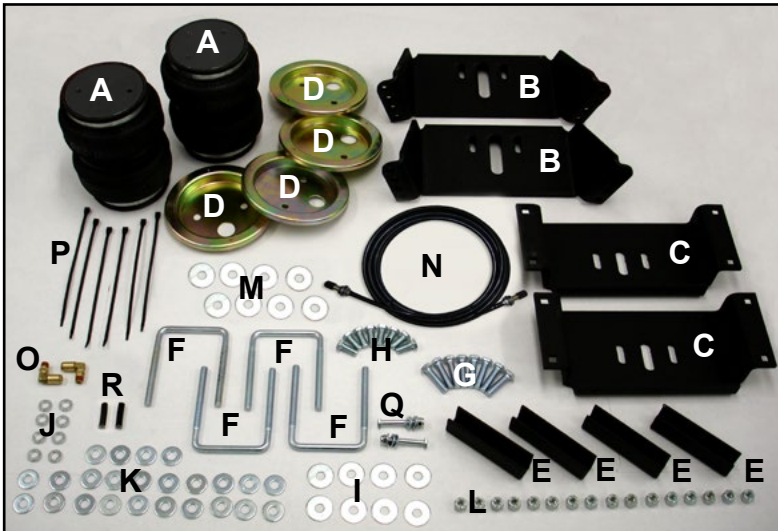

Make sure all the items shown in the photo are provided in your kit before starting the installation.

### CAUTION:

This kit includes “push to connect” airline fittings. They require the end of the airline to be round, square and cleanly cut to ensure the internal seal will not leak. The airline must only be cut with a sharp razor knife or hose cutter.

## KIT CONTENTS

A	Air Springs (2)	HP10000
B	Upper Brackets (2)	HP0044
C	Lower Brackets (2)	HP0104
D	Roll Plates (4)	HP10054
E	Spacer Bracket (4)	HP0028
F	3/8" NC x 6 1/2" U-bolts (4)	HP1018
G	3/8" NC x 1 1/2" bolts (8)	C18018
H	3/8" NF x 7/8" capscrews (8)	HP1002
I	3/8" Flat Washers Large O.D. (8)	HP1013
J	3/8" Lock Washer (8)	C18007
K	3/8" Flat Washer Small O.D. (24)	C653
L	3/8" Nylock Nuts (16)	HP1000
M	3/8" Flat Washer 1/8" Thick (8)	HP1135
N	Air Line/Valve Assembly	HP1344
O	Air Fitting (2)	HP1100
P	Tie Straps (6)	C11618
Q	1/4" Fastener, inner fender	HP1069, P02190, HP1072
R	Spacer Tube, inner fender	HP1070

## REQUIRED TOOLS

- 7/16", 1/2", 9/16" open end or box wrenches
- Adjustable Wrench
- Torque Wrench
- 7/32" Allen Wrench
- 9/16" & 1/2" deep well sockets
- Heavy Duty Drill
- 3/8" and 5/16" drill bits (very sharp)
- 3/8" Nut Driver
- Hacksaw
- Pipe Thread Sealant
- Hose Cutter, Razor Blade or Sharp Knife
- Air Compressor/Compressed Air Source
- Hoist or Floor Jack
- Safety Stands
- Safety Glasses
- Spray Bottle with Dish Soap/Water

Thank you and congratulations on the purchase of a AMP air suspension kit. Please read the entire installation manual prior to starting the installation to ensure you can complete the installation once started.

**IMPORTANT:**

This air suspension kit will not increase the GVWR (Gross Vehicle Weight Rating), as the GVWR is determined by the axle rating. Do not exceed the maximum capacity listed by the vehicle manufacturer.

**BEFORE STARTING:**

- 1) Ensure the application information is correct for the make, model and year of the vehicle you are installing it on.
- 2) Check the vehicle to see if it is equipped with a 5th Wheel Hitch. Some 5th wheel hitches require brackets to be mounted to the frame in the same locations as the air spring brackets (if this is the case, modifications of the 5th wheel hitch brackets may be required to mount this kit). Please contact Pacbrake at 800.663.0096)
- 3) Check the clearance between the outside of the frame and the inside of the tire, a minimum of 8" is required for air spring clearance.
- 4) Pacbrake recommends using a good quality anti-seize on all fasteners, this will reduce the chances of corrosion of the fasteners, and help facilitate removal if required at a later date.

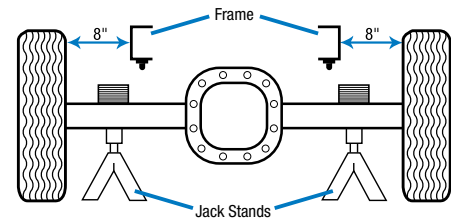

**PREASSEMBLY OF THE AIR SPRINGS ON THE LOWER BRACKET**

- 1 Locate the end of the air spring with the 1/8" NPT air port, place this side down with the air port away from you.
- 2 Place the roll plate over the end of the air spring, aligning the two mounting holes (rounded end towards the air spring). Then, place the lower mounting bracket with the flange towards you over the roll plate and air spring aligning the two mounting holes.

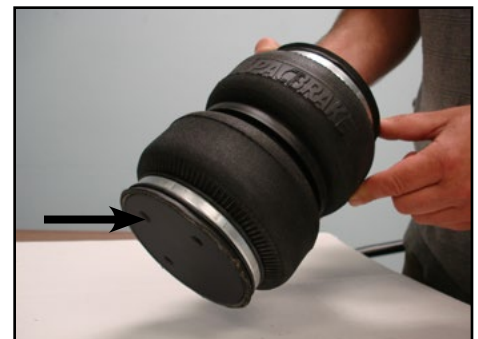

1



2

- Using the two  $\frac{3}{8}$ " NF x  $\frac{7}{8}$ " capscrews, flat and lock washers, loosely fasten the assembly together. Do not tighten the capscrews fully until final adjustment is performed in step 8.



3

Repeat steps 1 - 3 on the other side

## INSTALLATION ON THE VEHICLE

- Remove any unnecessary weight from the vehicle to attain Normal Ride Height. This is important for correct initial air spring set-up and adjustment. Park the vehicle on a level concrete surface.

Raise the rear axle with a floor jack enough to remove both rear wheels and attain a comfortable working height. Place two jack stands under the axle as shown in the photo. Lower the floor jack until the vehicles axle is supported by the jack stands.



4

- 1994 and newer Dodge 4X4 trucks only.** Removal of the rear wheelhouse liner is required to access the frame. Remove the 4 plastic rivets shown in the drawing by pushing the inner pin through from the outside. Then remove the 3 capscrews securing the liner to the box. Rotate the liner towards the rear of the vehicle to remove. Save the 4 plastic rivets for reassembly.

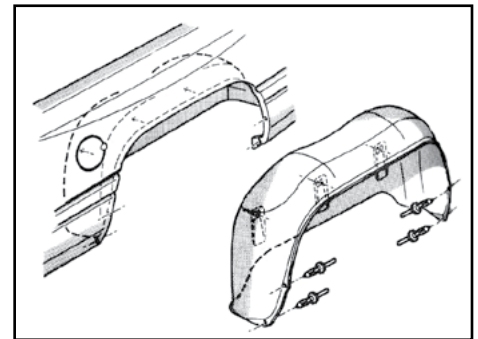

5

- Place the lower air spring assembly on top of the leaf spring with the flanged side of the lower bracket facing outward. Center the lower bracket above the center of the axle tube. Place the upper bracket on top of the air spring assembly. Check the vehicle frame where the upper air spring bracket flanges meet, some trucks will have an impression in the frame, these vehicles require the spacers provided be installed as shims to compensate.

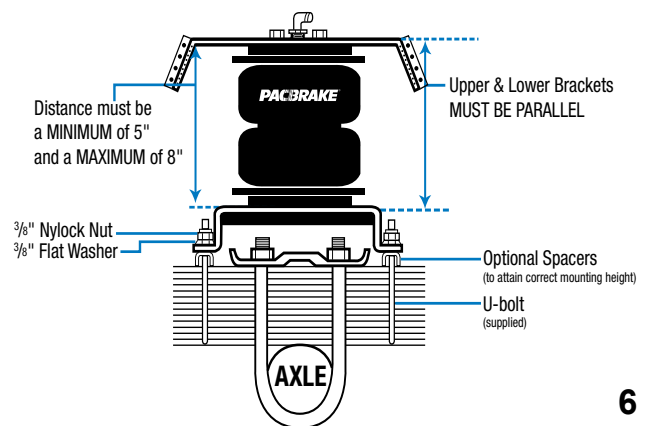

6



- 7** Using the 2 “C” clamps, clamp the upper bracket to the frame. If necessary, install the frame to bracket spacers. Ensure the center of the brackets are centered above the axle for correct alignment. Ensure the minimum and maximum distances (from step 6) are achieved and the brackets are parallel to each other. 4 spacer brackets are provided to attain correct mounting height if necessary, install them between the leaf spring and the lower bracket.

**NOTE:** Remove the lower air spring assembly when drilling the holes in the frame to avoid metal chips falling into the lower roll plate cavity. Install the 90° air supply fitting into the top of the air spring using thread sealant.



7

- 8** Once the correct position of the upper bracket is confirmed choose the 2 best mounting holes in each flange, top and bottom holes preferred. Check the inside of the frame for obstructions like electrical harnesses before drilling. Using the bracket as a template drill 4-3/8" mounting holes. Fasten the bracket using the 3/8" x 1 1/2" fasteners, small O.D. washers under the head of the fastener and the large O.D. washers on the inside of the frame, the nylock nuts and any spacers required between the upper bracket and the frame. Torque the fasteners to 40 ft-lbs.

AIR SPRING ALIGNMENT

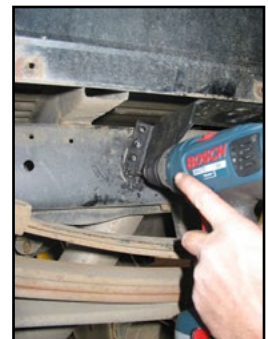
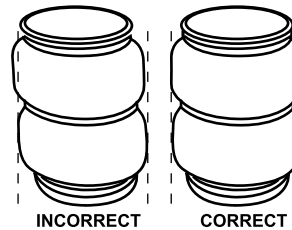

8

- 9** Reinstall the lower air spring assembly. Using the 3/8" x 7/8" capscrews, flat and lock washers loosely fasten the top of the air spring to the upper bracket. Install the “U” bolts around the leaf spring and through the two holes in the lower bracket. If the vehicle has overload springs, install “U” bolts as shown. Otherwise, install “U” bolts around the entire leaf pack. Adjust the air spring on their brackets to achieve correct alignment. Once the correct alignment is achieved, tighten the **upper and lower brackets** to the air spring. Torque to 20 ft-lbs.



9

- 10** Tighten the front and rear “U” bolts around the leaf spring pack. Use the nylock nuts and small O.D. flat washers, torque to 16 ft-lbs. Cut off the threaded portion of the “U” bolt above the nyloc nut.

**Repeat steps 4 to 10 on the other side of the vehicle.** Reinstall the inner fender liner if removed. A spacer and 1/4" fastener is provided to replace the center capscrew and space the liner away from the air spring.



10

11

**AIRLINE INSTALLATION**

11 Provided in the basic air spring kit are two fill valves, the most common place to install them is to replace the license plate fasteners with the fill valves. Alternatively, two holes can be drilled in a convenient location. Install one airline provided, route the nylon hose to an air spring fitting, cut the hose and connect to the air spring fitting. Repeat with the other fill valve. Secure airlines with the tie-straps provided away from moving items and heat sources.



If an in cab inflation kit is being installed, follow the instructions provided with it.

NOTE: This kit contains push to connect fittings, using scissors or wire cutters to cut the nylon airline will distort the line and cause the connection to leak. THE AIRLINE MUST BE CUT OFF SQUARELY WITH A SHARP RAZOR KNIFE. Moisten the end of the airline prior to inserting it into the fitting and push it in until it stops.

**LEAK CHECK**

12 Inflate both the air springs to 90 PSI. Use a dish soap and water mixture on all airline connections to detect air leaks. Repair as necessary and retest. Inflate the air springs to a predetermined value and then the following day recheck the pressure. If one or both of the air springs have lost pressure, a leak is present. The leak must be repaired and then retest the vehicle until no leaks exist.



12

**OPTIONAL ACCESSORIES**

Pacbrake offers an optional dual needle air gauge to monitor the pressure in each spring from the vehicles cab. Pacbrake offers a full line of air compressors, air tanks and solenoids to control your air spring system.

**OPERATING YOUR VEHICLE WITH PACBRAKE AIR SUSPENSION**

Air springs have minimum and maximum pressure requirements. Never operate your vehicle with less than 10 PSI in the air spring and never inflate the air springs over 100 PSI. Damage to the air springs will result.

Check the air pressure in the air springs daily for the first couple of days to ensure a leak does not develop. The air springs are designed to maintain the vehicles stock ride height with a load. Do not use the air springs as a means to lift the vehicle with no load. A rough ride will result.



**SERVICING YOUR VEHICLE WITH PACBRAKE AIR SUSPENSION**

When lifting the vehicle with a floor jack or hoist on the frame, never allow the air spring to limit the travel of the axle. Try to always jack the vehicle on the axle. Suspending the axle with the air spring limiting the axle travel will damage the air spring and void the air spring warranty.

**WARRANTY**

To be eligible for warranty, owner must submit their warranty card or register online within 30 days of purchase date.

NOTE: The owners warranty will be void if air springs run with less than the minimum of 10 PSI.