

INSTALLATION GUIDE

AMP RESEARCH Power Step

MADE IN USA

APPLICATION

AMP Part

Chevrolet Silverado / GMC Sierra - Crew Cab 2011 - 2014 75146-01A (Diesel Only)

Chevrolet Silverado / GMC Sierra - Ext Cab 2011 - 2014* 75146-01A (Diesel Only)

*Modification required to running board assembly. See Item 1 on page 3.

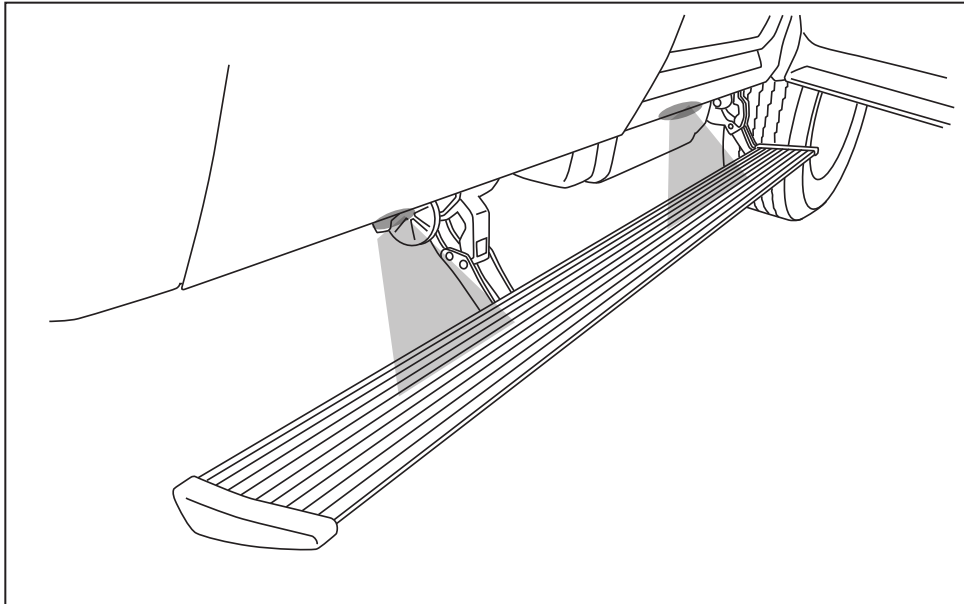

INSTALLATION TIME

3-5 Hours

Professional installation recommended

SKILL LEVEL



4= Experienced

TOOLS REQUIRED

- Safety goggles
- Measuring tape
- Power Drill
- 9/32" drill bit
- 10 mm socket
- 13 mm socket
- 21 mm socket
- Ratchet wrench and extension
- Wire crimpers
- Wire stripper / cutter
- 3/16" hex key wrench (allen wrench)
- 4mm hex key wrench (allen wrench)
- Electrical tape
- Weather proof caulking (silicone sealer)
- Silicone spray

Scan the QR code with your smartphone to view videos on YouTube.



<http://youtu.be/i7tkWahELEY>



<http://youtu.be/da2n8KxwasU>

WARRANTY

5-Year Limited Warranty

AMP RESEARCH TECH SUPPORT 1-888-983-2204 (Press 2) Monday - Friday, 6:00 AM - 5:00 PM PST

Invented, engineered and manufactured exclusively by AMP Research in the USA. May be covered by one of the following patents: 6,641,158; 6,830,257; 6,834,875; 6,938,909; 7,055,839; 7,380,807; 7,398,985; 7,584,975 ©2012 AMP Research. All rights reserved. Printed in USA.

INSTALLATION GUIDE

Attaching motor to Linkage assembly. **To be assembled in Step 6.**

EXPLODED VIEW

- Motor
- Socket cap screw
- Washer
- Drive Gear Housing Cover

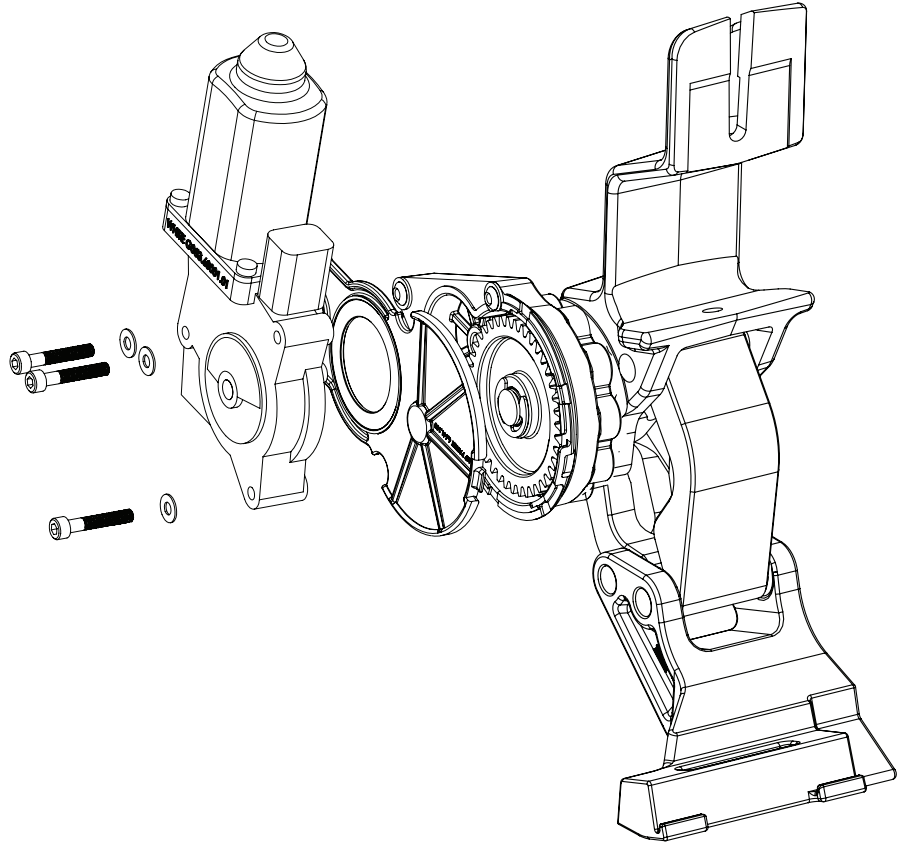
**CAUTION: HANDLE WITH CARE.**

The motor must be put on in Step 6 after the linkage is tightened to the body of the vehicle.

To ensure our customers receive all components with full integrity, we pack the motors separate from their linkage assemblies. This requires that the installer position and fasten the motor before continuing with the install. Please follow the instructions below and handle the assembly carefully.

CAUTION: Dropping the assembly or any excessive impact MAY cause damage to the motor.

Instructions:

1. Position the gear cover in place as shown if not already in place.
2. Seat motor into position on the three mounting bosses. This may require an adjustment of the gear by moving the swing arms.
3. After seating into place, fasten the motor with the three motor mount screws with 4mm Hex Head. Tighten screws to 36 in-lbs (4N-m). **Do not over torque.**

Note: Some Applications require modification.

Application	Cut Length
Crew Cab	85" (No Modification Required)
Extended Cab	79" (Trim 6" off of Board)

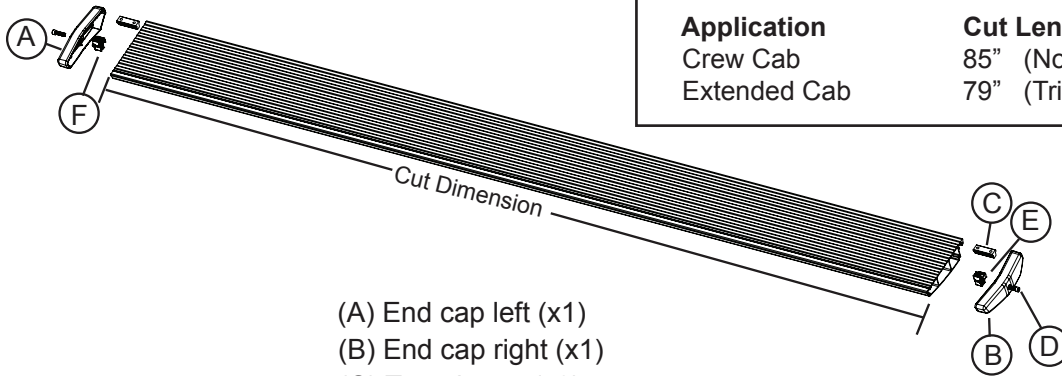

- (A) End cap left (x1)
- (B) End cap right (x1)
- (C) T-nut insert (x2)
- (D) Socket cap screw (x2)
- (E) End cap wedge right (x1)
- (F) End cap wedge left (x1)

1 x2

Running board assembly

Note: The jogs in the lower part of the linkages point toward one another.

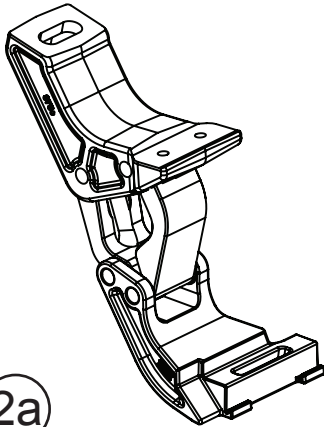

2a

Driver Idler Linkage assembly

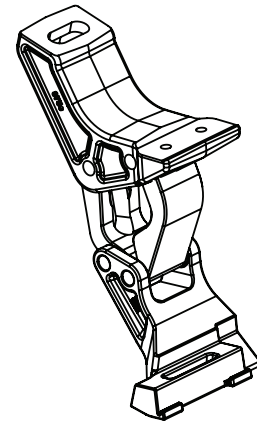

2b

Passenger Idler Linkage assembly

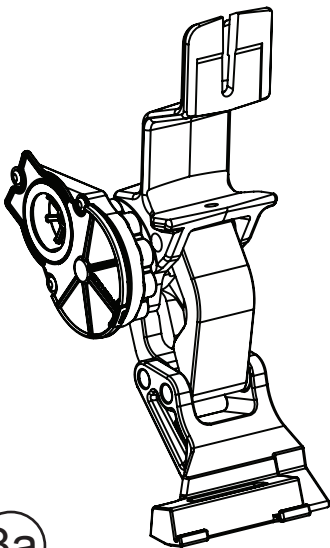

3a

Driver Motor Linkage assembly

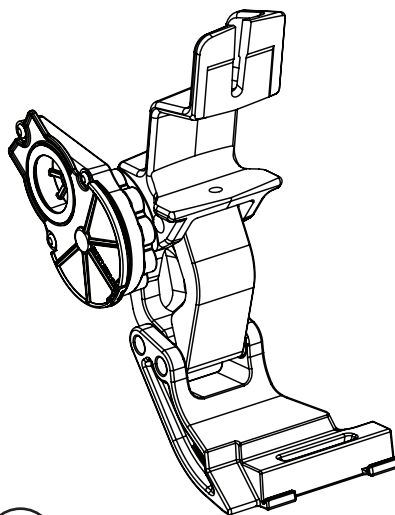

3b

Passenger Motor Linkage assembly

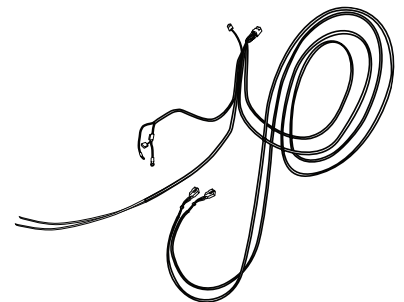

4

Wire harness

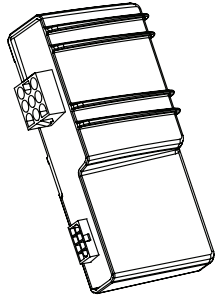

5
Controller STA

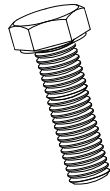

6 x6
Hex Bolt



7 x6
Washer

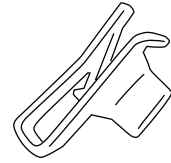

8 x2
U-nut

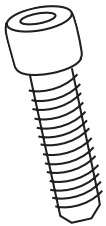

9 x8
Socket Cap Screw

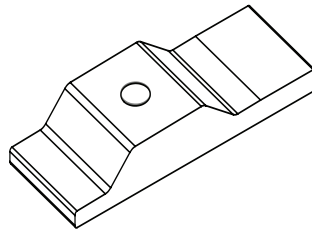

10 x2
Fender Spacer

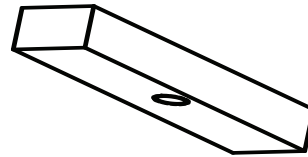

11 x2
Threaded Clamping Plate

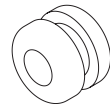

12
Grommet

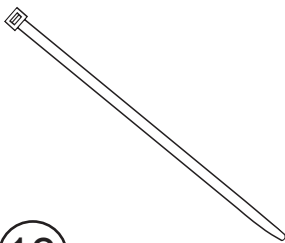

13 x20
Cable tie (7")

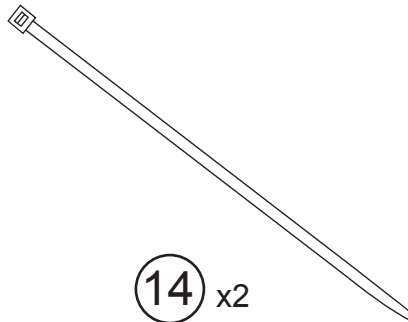

14 x2
Cable tie (11")

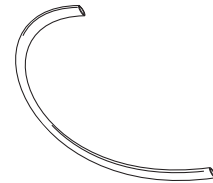

15
Tubing (Installation Tool)



16 x4
Posi-Tap™

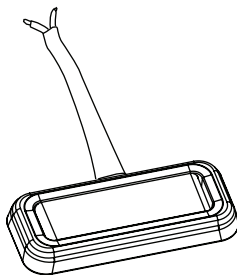

17 x4
LED Lamp

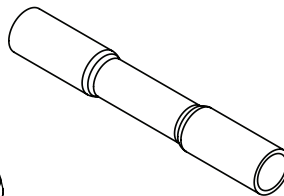

18 x8
Butt Connector

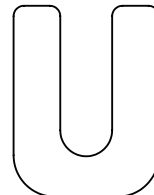

19 x2
Shim



20 x2
Shim
(Alternate shim. See step #1)

AMP RESEARCH POWERSTEP™ – CHEVROLET / GMC

Remove Passenger and Driver side Fender and body mount bolt. Body mount bolt will be reused. Install front Idler Linkages.

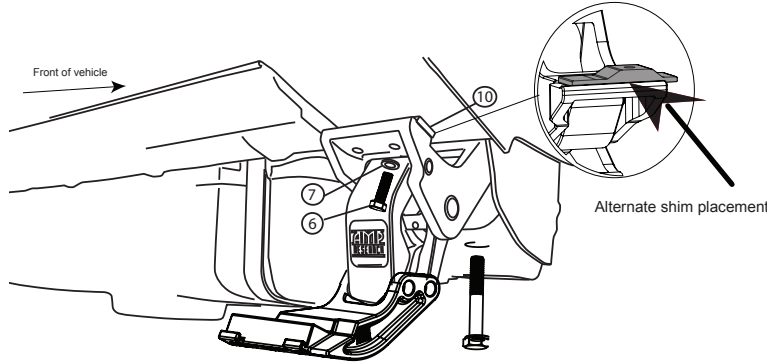

1 Install Fender Spacer between fender and Idler Linkage (10) Spacer hole and mounting hole faces towards front of vehicle. Install fastener (6) with washer (7), and replace Body mount bolt. Finger tighten only. Note: Due to build differences the alternate shim (20) on parts list may be needed between body spacer (10) and linkage upper mount.

Install Passenger and Driver side Motor Linkage in fourth sheetmetal tab / hole from front. Extra Cab: See measurements below for location.

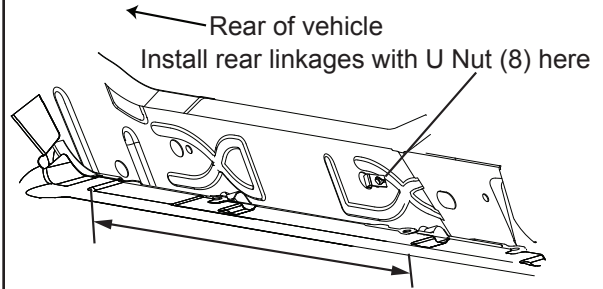

2 Crew Cab- Approx 26 1/4" from back of cab
Extended Cab- Approx 11" from back of cab

Install threaded clamping plate (11) on top of pinch weld and thread fastener (6) with washer (7) into clamping plate. Finger tighten bolt. Install fastener (6) with washer (7), finger tighten only.

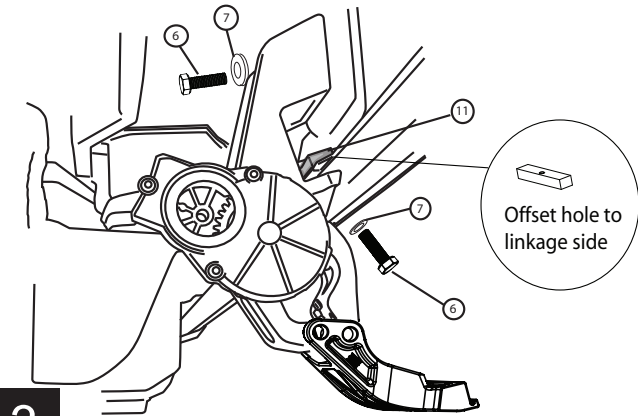

3

Slide mounting T-nut into position, slide the board back so that the front end cap is against the front Linkage. Finger tighten only.

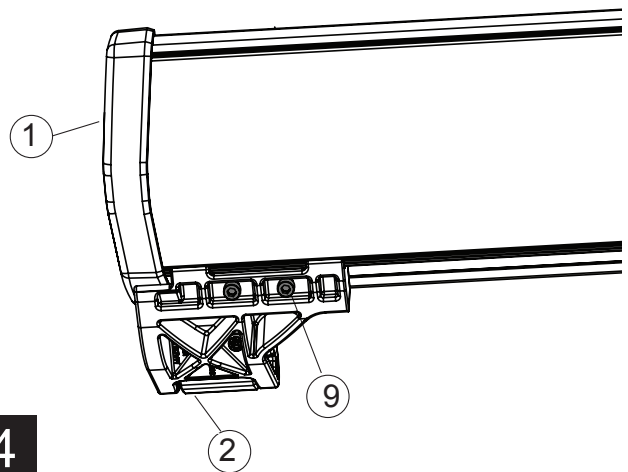

4

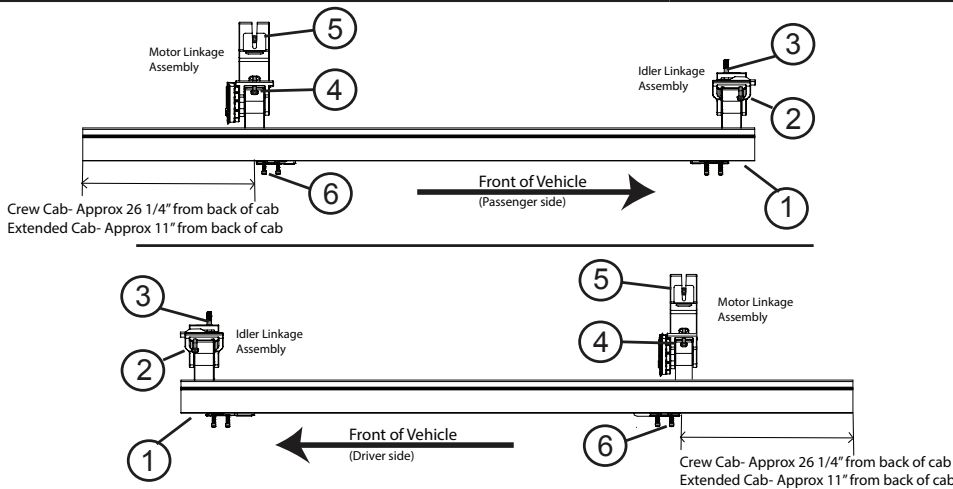

Note: Due to vehicle-build variations the Power Step may not correctly align with vehicle cladding. Provided Shims (19) may need to be installed between body mount and idler linkage once Power Step is installed.

Note: After each step of the torquing process check for binding in the system. Steps should deploy under own weight.

In order to prevent any binding follow the torquing order listed above.

5 1) Torque Socket cap screws to 10 ft-lbs. 2) Torque Hex head screw to 16 ft-lbs. 3) Torque body mount bolt to 44 ft-lbs. 4) Torque Hex head screw to 16 ft-lbs. 5) Torque Hex head screw to 16ft-lbs. 6) Torque Socket cap screws to 10 ft-lbs.

AMP RESEARCH POWERSTEP™ – CHEVROLET / GMC

Install motor onto Motor Linkage Assembly. See page 2 for motor installation instructions.

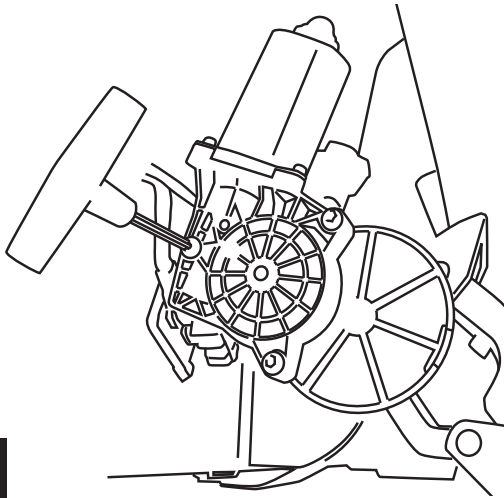

6

Using the two 11" cable ties, mount controller to the support arm next to the battery.

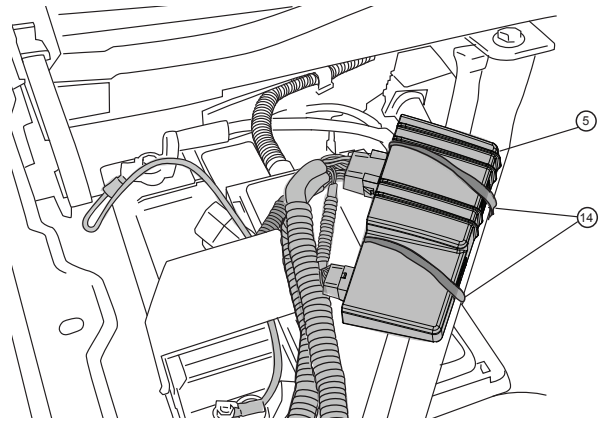

7

Plug in wire harness.
(Ensure that locking tabs engage.)

Remove fuse from harness.

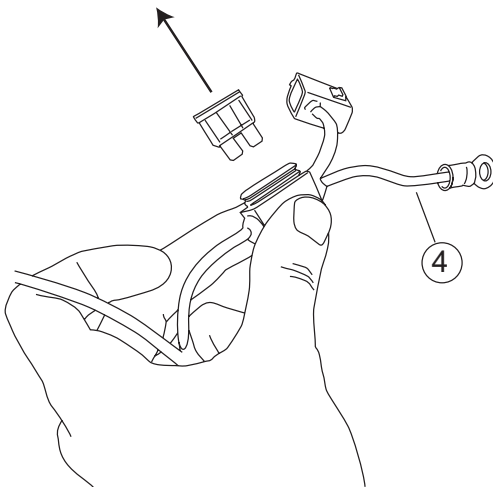

8

Attach power lead (RED wire) to positive pole on the battery and Negative lead (BLACK wire) to negative pole on the battery.

CAUTION: Do not ground wrench when engaged with nut.

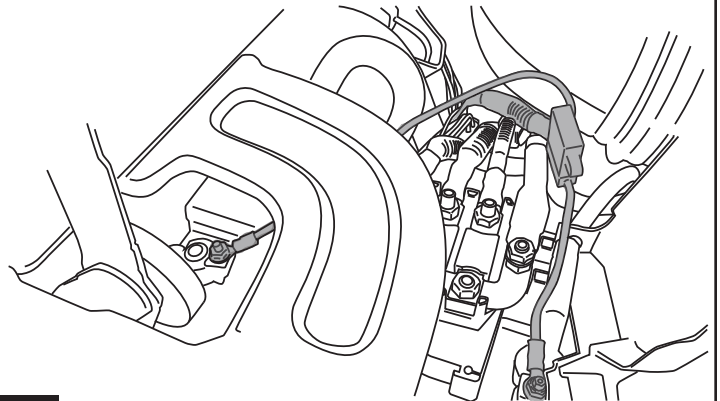

9

Route long end of wire harness above engine and down through drivers side wheel well. Zip tie harness to cowlings clips on fire wall. Route short end down passengers side.

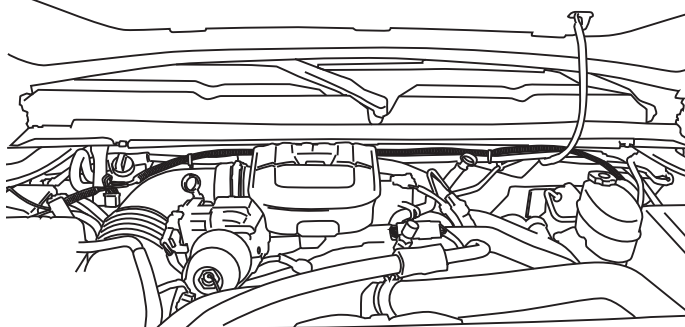

10

Secure with zip ties.

11

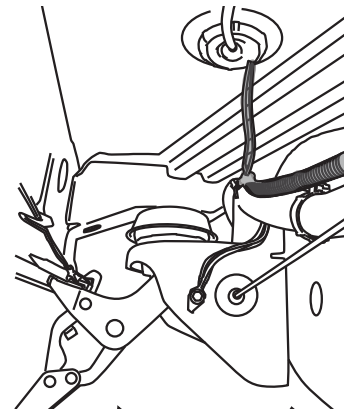

IMPORTANT: Step 15 and 16 are for Crew Cab trucks only. (Not used on Extended Cab Trucks)
 (Light Blue and Green wires are only used with Crew Cab trucks.)

Pop off the threshold cover with screwdriver and remove the kick panel. **Repeat step on passenger side.**

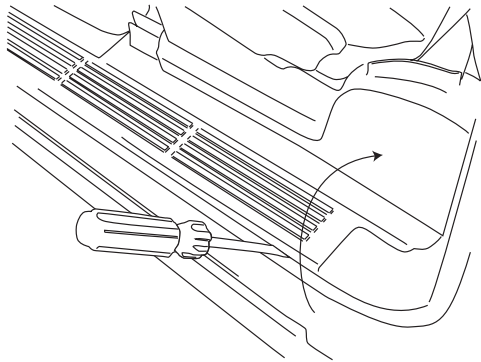

12

Pull up the carpet and thread both wires through the floor panel **See step 14 for passenger side**

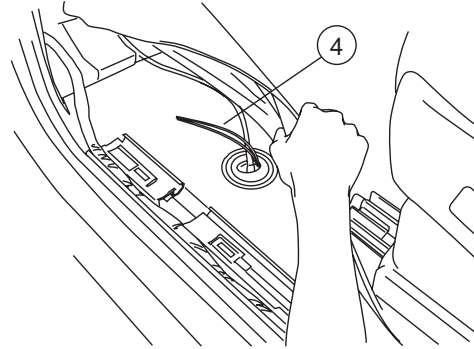

13

Seal holes with silicone glue and cover with tape so carpet does not stick to glue.

Pull up carpet and drill a 9/32" hole in floor and add rubber grommet) **Caution: Do not drill through DEF tank when drilling hole.**
For all vehicles except Crew Cabs skip to step 18.

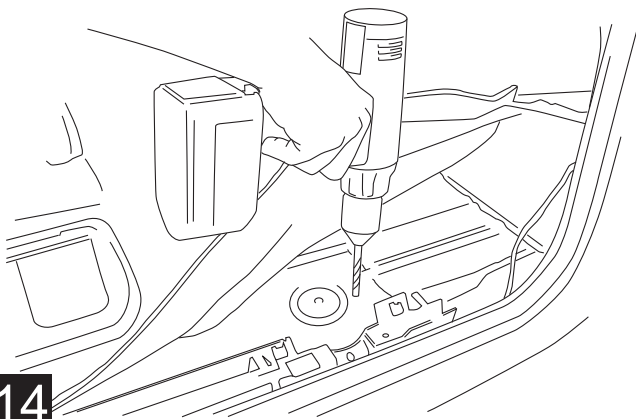

14

Crew Cab Only (Rear Doors) - Carefully remove wire wrap and find LIGHT BLUE wire with BLACK STRIPE. On passenger side find GREEN wire with BLACK STRIPE. The wire is located rear of the "T" junction where wires cross under the front seat.

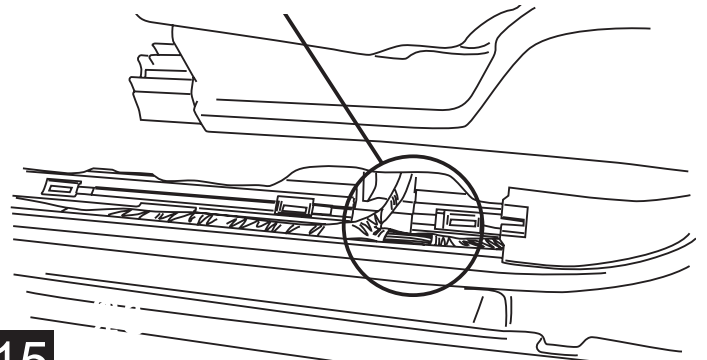

15

Crew Cab Only. Using supplied Posi-Tap™ connector, splice shorter trigger wire into wire found in Step 15. Otherwise tape off short wire.

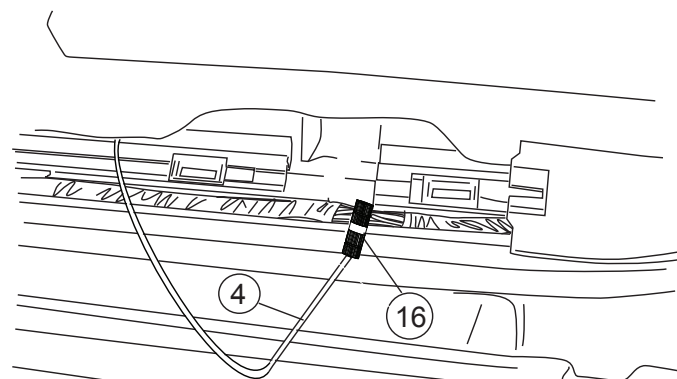

16

Posi-Tap™ instructions

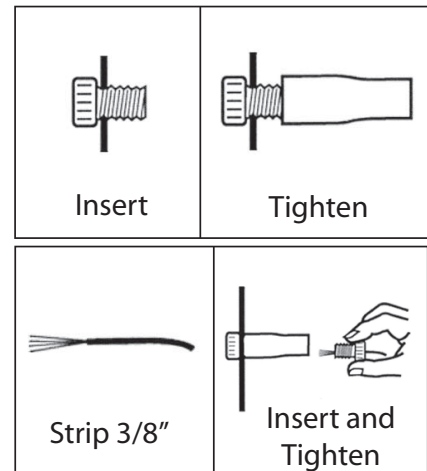

17

Remove plastic trim on door near mirror attachment. Then carefully pry up window/ door lock switch plate.

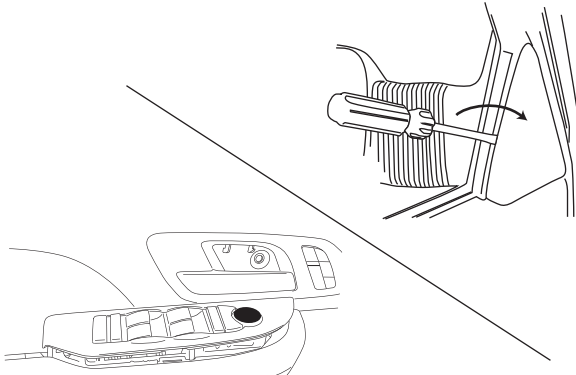

18

Remove all plugs from switchplate

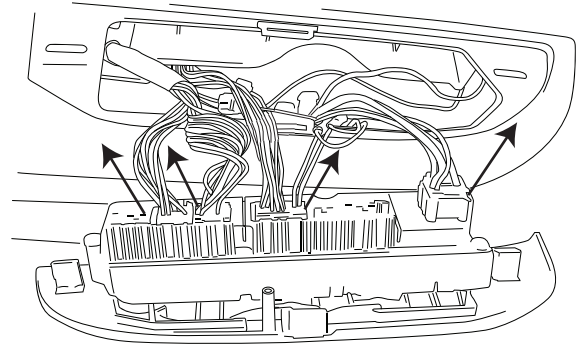

19

To remove door panel, first pry back tab on door lock to remove then pry off plastic covers by handle and door latch. Remove the 3 door bolts and then remove door panel by prying loose all panel fasteners.

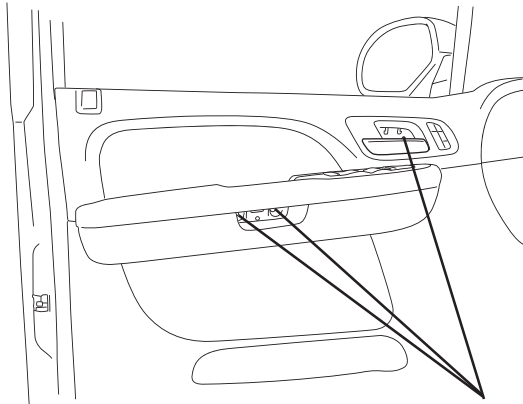

20

Remove door latch cable from door panel.

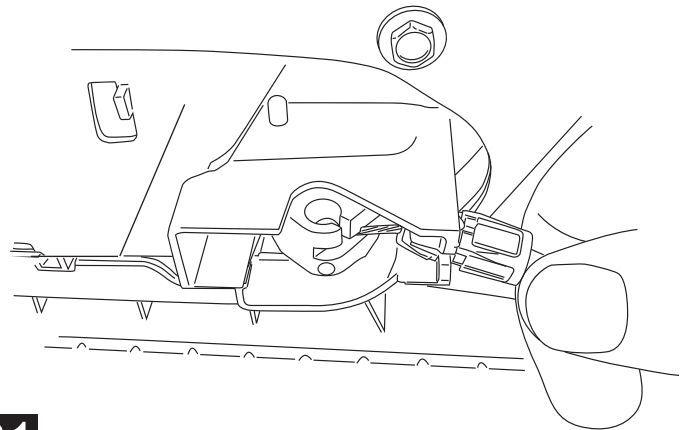

21

Pull back the door weather guard. Thread plastic tube through accordion between the body and the door.



22

Feed longer wire of Step 15 through tube into door and pull out plastic tube shown on door side. Route wire along harness to wire show in step 24.

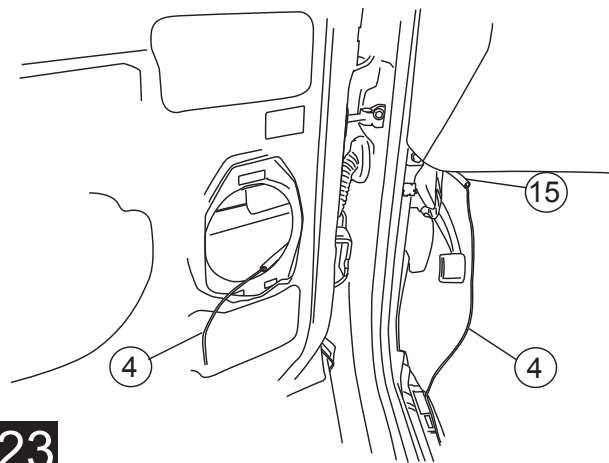

23

AMP RESEARCH POWERSTEP™ – CHEVROLET / GMC

Locate loom that runs across the top of the door panel. Carefully remove wire wrap and locate the following wires on either side. **Drivers side:** Grey / Black wire **Passenger side:** Tan / White wire **Caution: Zip tie trigger wires to avoid being hung up in window linkage.**

On each side of the vehicle measure from the front edge of door line on the pinch weld to the specified lengths below. Measure at 22" for front LED Light and 65" for rear LED Light.

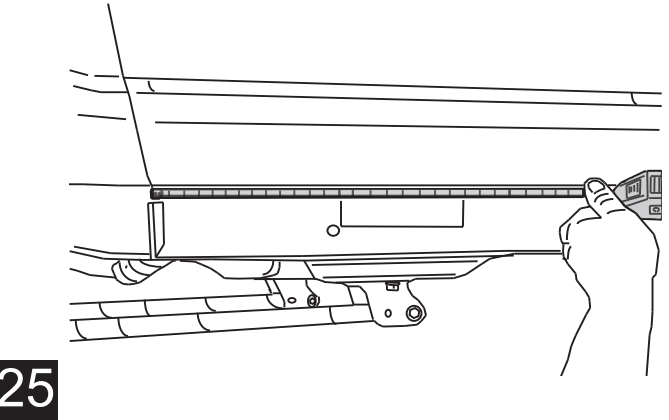
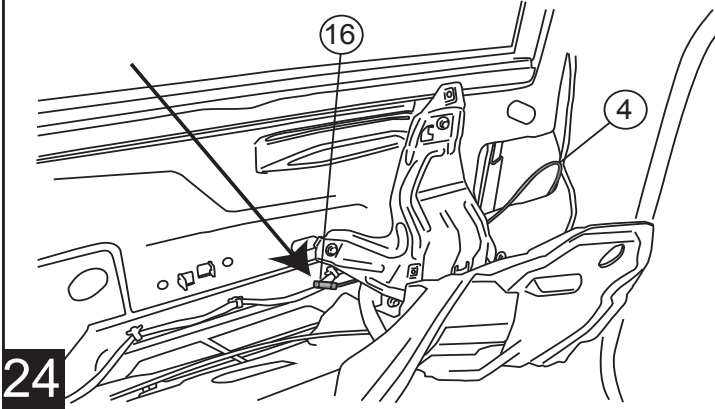

24

25

Affix lamp to rocker panel surface. Make sure the lamp is affixed to a clean, flat surface. There is a step down midway across the surface. Affix lamp just outside of step down.

Using supplied butt connectors, connect the lamp wires. Red to Red, Black to Black. Once Crimped use heat gun to shrink tube.

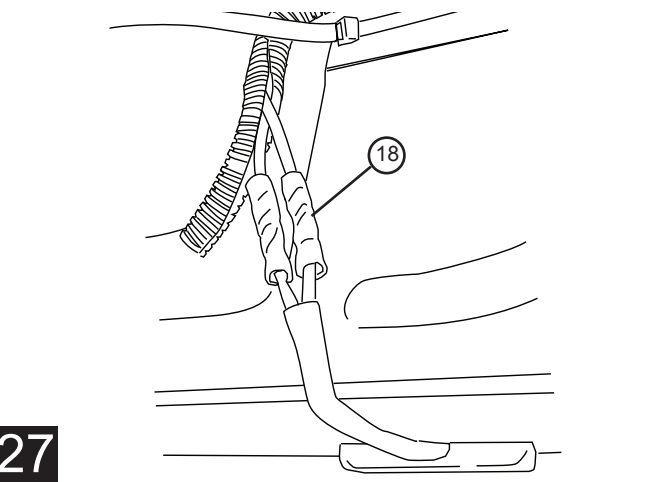
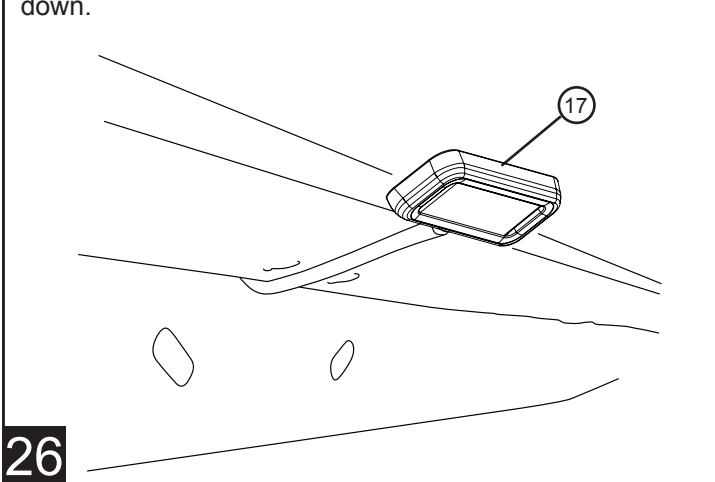

26

27

Close and wrap with conduit and electrical tape. Secure all loose wires with cable ties, with lamp wires pulled upward to avoid any wire snagging.

Reinstall fuse.

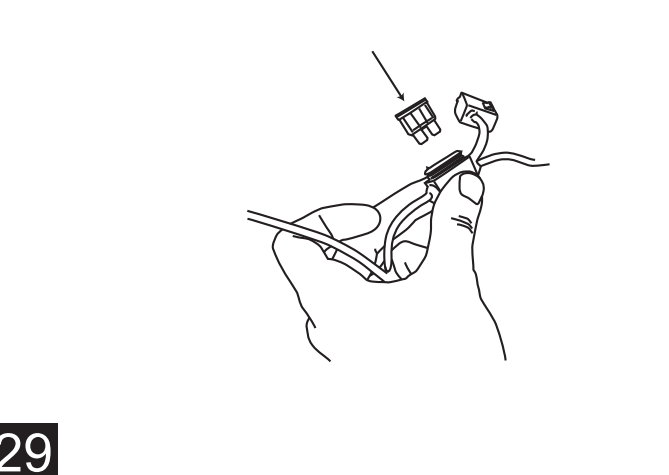
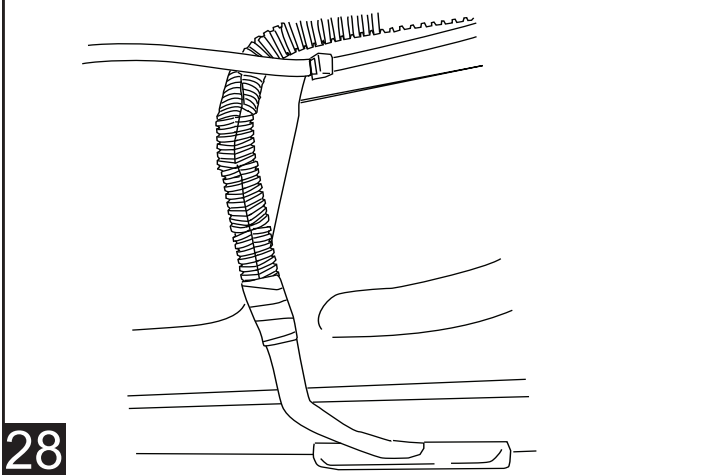

28

29

Check that all doors activate the Power Step and the LED Lights work when doors open and close. Reinstall any remaining trim panels.

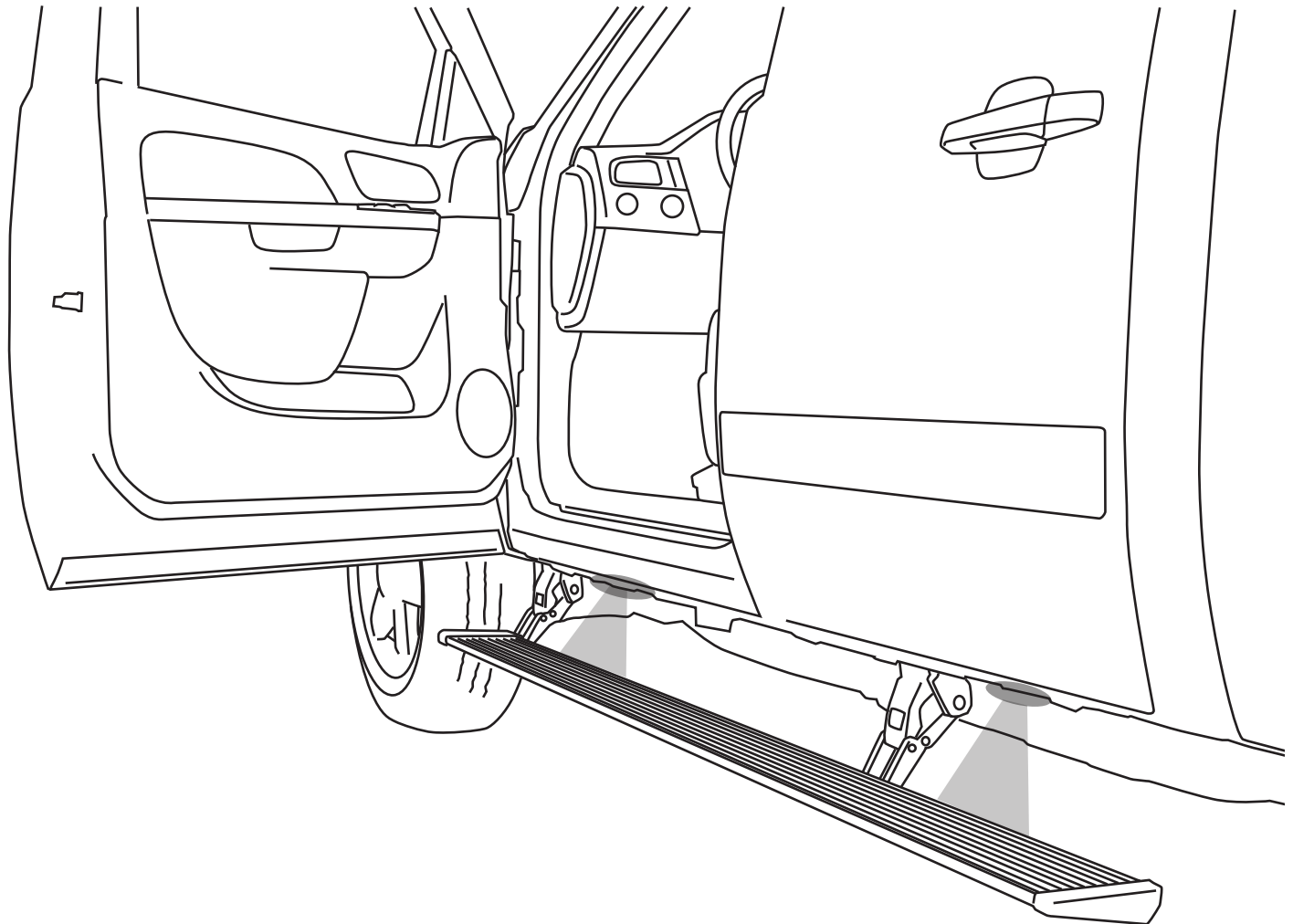

FINAL SYSTEM CHECK

Check that all doors activate the PowerStep and the LED lights work when doors open and close.

NORMAL OPERATION: When the doors open, PowerStep automatically deploys from under the vehicle. When the doors are closed, PowerStep will automatically return to the stowed/retracted position. **Note that there is a 2-second delay before the PowerStep returns to the stowed/retracted position.**

CORRECT OPERATION OF LIGHTS: All four lamps will illuminate upon opening any door of vehicle. Lamps will stay on until restowing of both Power Steps or until 5 minutes has expired with the doors open. When the lights timeout after 5 minutes, they can be reilluminated by closing and opening any door of vehicle.



Congratulations on your purchase of the genuine AMP Research PowerStep! Here's what you should know...

POWER-DEPLOYABLE RUNNING BOARDS OPERATION: AMP Research PowerStep running boards automatically move when the doors are opened to assist entering and exiting the vehicle.

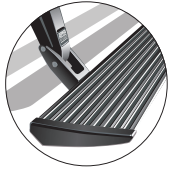

Automatic power deploy:

The running boards will extend down and out when the doors are opened.

Automatic power stow:

The running boards will return to the stowed position when the doors are closed. There will be a 2-second delay before the running boards move to the stowed position.

Automatic stop:

If an object is in the way of the moving running board, the running board will automatically stop. To reset, clear any obstruction, then simply open and close the door to resume normal operation.



Manually set in the deployed (OUT) position for access to the roof:

The running boards can be manually set in the deployed position by firmly holding the step down with your foot while at the same time closing the door. To resume normal operation, open and close the door.

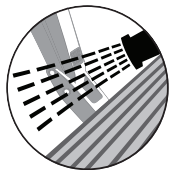

Maintenance: In adverse conditions, debris such as mud, dirt, and salt may become trapped in the running board mechanism, possibly leading to unwanted noise. If this occurs, manually set the running boards to the deployed position and flush the front and rear hinge arms with a high-pressure car wash wand.

Avoid spraying the motors directly. After washing, apply silicone spray lubricant to the hinge pivot pins. Do not apply silicone, wax or protectants like Armor All® to the running board stepping surface.

Caution! Keep hands away when the running board is in motion.

5-YEAR LIMITED WARRANTY

AMP RESEARCH warrants this product to be free from defects in material and workmanship for FIVE (5) YEARS FROM DATE OF PURCHASE, provided there has been normal use and proper maintenance. This warranty applies to the original purchaser only. All remedies under this warranty are limited to the repair replacement of the product itself, or the repair or replacement of any component part thereof, found by the factory to be defective within the time period specified. The decision to repair or replace is wholly within the discretion of the manufacturer.

This warranty specifically excludes labor. If you have a warranty claim, first you must call our factory at the number below for instructions. You must retain proof of purchase and submit a copy with any items returned for warranty work. Upon completion of warranty work, if any, we will return the repaired or replaced item or items to you freight prepaid. Damage to our products caused by accidents, fire, vandalism, negligence, misinstallation, misuse, Acts of God, or by defective parts not manufactured by us, is not covered under this warranty.

ANY IMPLIED WARRANTIES OF MERCHANTABILITY AND/OR FITNESS FOR A PARTICULAR PURPOSE CREATED HEREBY ARE LIMITED IN DURATION TO THE SAME DURATION AND SCOPE AS THE EXPRESS WRITTEN WARRANTY. OUR COMPANY SHALL NOT BE LIABLE FOR ANY INCIDENTAL OR CONSEQUENTIAL DAMAGE.

Some states do not allow limitations on how long an implied warranty lasts, or the exclusion or limitation of incidental or consequential damages, so the above limitations or exclusions may not apply to you. This warranty gives you specific legal rights, and you may also have other rights that vary from state to state.

FOR WARRANTY ISSUES WITH THIS PRODUCT PLEASE CALL AMP RESEARCH CUSTOMER SERVICE 1-888-983-2204

WARNING

Be sure to read and precisely follow the provided instructions when installing this product. Failure to do so could place the vehicle occupants in a potentially dangerous situation. After installing or reinstalling, re-check to insure that the product is properly installed.