



**DOWNLOAD ENHANCED
INSTALL MANUALS AT
*dieselperformance.com***



BD SUPERMAX SXE Turbocharger

2001-2004 Chevrolet/GMC LB7 Duramax Turbo Kit





| Part # | Configuration |
|----------------|----------------------|
| 1046220 | SXE 64 |
| 1046221 | SXE 66 |
| 104622 | SXE 69 |



PLEASE READ ALL INSTRUCTIONS BEFORE INSTALLATION.



UNLESS AN EO# IS LISTED, THIS PRODUCT IS LEGAL IN CALIFORNIA FOR RACING VEHICLES ONLY, WHICH MAY NEVER BE USED UPON A HIGHWAY.

KIT CONTENTS:





Please check to make sure that you have all the parts listed in this kit before you start the disassembly of your truck.





| DURAMAX 2001-04 LB7 "SUPERMAX" SINGLE TURBO KIT | | | |
|---|---|---|---|
| 1406230/1406231/1406232 | 1462327 | 1453251 | 1462326 |
|  |  |  |  |
| SuperMAX Turbo Qty: 1 | Check Valve Qty: 1 | Oring Qty: 1 | 12mm O-ring Plug Qty: 1 |





| 1462323 | 1462324 | 1462325 |
|---|---|--|
|  |  |  |
| 14mmx JIC -6 Adapter Qty: 1 | Lower Oil Feed Line Qty: 1 | Upper Oil Feed Line Qty: 1 |

| 1462310 | 1406210 | 1462410 |
|---|--|---|
|  |  |  |
| Lower Oil Engine Block Gasket Qty: 1 | Turbo Adapter (Pedestal) Qty: 1 | Feed Pipe Gasket (Upper) Qty: 2 |

| 1462300 | 2405006 | 1462301 |
|---|---|---|
|  |  |  |
| Oil Outlet Block Qty: 1 | Turbo Oil Drain Gasket Qty: 1 | Stud Qty: 2 |

| | | | |
|---|---|--|---|
| 1462420 | 1462430 | 1462441 | 1040142 |
|  |  |  |  |
| Feed Pipe Gasket (Lower) | Turbo Mount Stud | Turbo Mount Nut | Heat Wrap |
| Qty: 1 | Qty: 4 | Qty: 4 | Qty: 2 |

| | | | |
|---|---|--|---|
| 1459113 | 1453514 | 1453504 | 1405926 |
|  |  |  |  |
| Heat Wrap Wire | Header Wrap | Stainless Zip Tie | Turbo V-Band Clamp |
| Qty: 5 ft. | Qty: 1 Roll | Qty: 3 | Qty: 1 |





| | | | |
|---|---|---|---|
| 1100740 | 1462601 P | 1405222 | 1453701 |
|  |  |  |  |
| S/S Exhaust Clamp | Inlet Pipe | 4" Silicone Hose | 4" Hose Clamp |
| Qty: 1 | Qty: 1 | Qty: 4" | Qty: 2 |

| | | |
|----------------|----------------|----------------|
| 1330149 | 1462110 | 1462115 |
|----------------|----------------|----------------|

| | | |
|---|--|---|
|  |  |  |
| Hose Clamp Qty: 2 | Coolant Hose Qty: 20 in. | Coolant Hose Hold-down Qty: 1 |

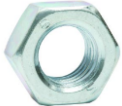
| |
|--|
| 1462905 |
|  |
| Dipstick Tube Qty: 1 |

| |
|---|
| 1462501 |
|  |
| Turbo Down Pipe Qty: 1 |

| | | | | |
|---|---|---|---|---|
| 1110032 | 1462101 | 1300131 | 1452225 | 1406211 |
|  |  |  |  |  |
| 5/16 NF Nut Qty: 2 | Heat Shield Bracket Qty: 1 | Zap Strap Qty: 2 | Comp. Outlet Clamp Qty: 1 | Outlet Adapter Qty: 1 |

Pre-Installation

A turbocharger is driven solely on exhaust energy. Therefore, if the vehicles current exhaust manifold is cracked or is leaking, it is recommend that new exhaust gaskets and a heavy-duty exhaust manifold be used.

Installation should occur on a cold vehicle, as turbo and exhaust components become very hot with use.

The **BD SuperMax Turbocharger System** is recommended for trucks with 400-550 RWHP with a maximum efficient boost pressure of 45psi. For optimum performance, the turbo should operate between 40–45psi.

Upgrade Options

| Description | Part # |
|------------------------------------|----------------|
| BD Allison Torque Convertor | 1030230 |
| BD Allison H/D Transmission | CALL |
| BD X-Monitor Digital Gauge Package | 1086210 |
| BD Deep Sump Transmission Pan | 1061600 |
| BD Cool Down Timer 2 | 1081160 |

Pre-Installation

Record your radio settings if you prefer as you will lose them once your batteries are disconnected.

Disconnect the negative terminals on both of the vehicle’s batteries, and then disconnect the positive terminals.

If the stock turbocharger has failed, perform the following steps to verify the condition of the #4 camshaft. Although this oil feed does not supply the BD turbo, it is always recommended to check the state of your engine.

- A. Visually inspect for correct alignment of the #4 camshaft bearing oil hole through the turbocharger oil supply hole in the block.***
- B. Turn the engine over by hand (1/2 turn) and inspect for camshaft bearing movement, indicating a spun camshaft bearing.***
- C. If the bearing is spun the engine MUST be replaced.***

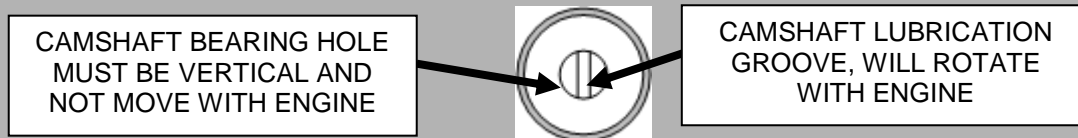

Installation

Removal of Stock Turbo & Parts

Remove the factory plastic engine cover or intake plenum. You can also remove the intake tube, but you can leave the air box in place.

Using the petcock on the bottom of the radiator, drain the engine coolant into a clean container to reuse later.

Using a 1/2" breaker bar, relax the belt tensioner and remove the belt.

Disconnect the Air Conditioning clutch and high-pressure cutout electrical connectors.

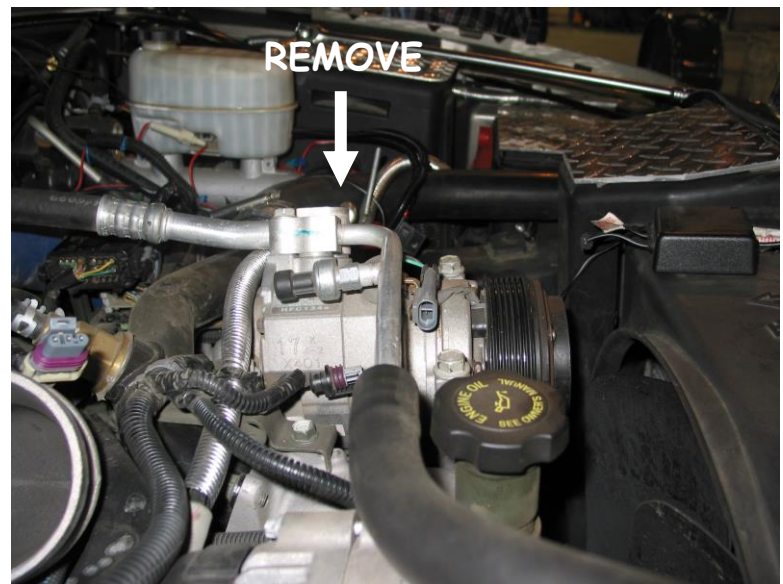
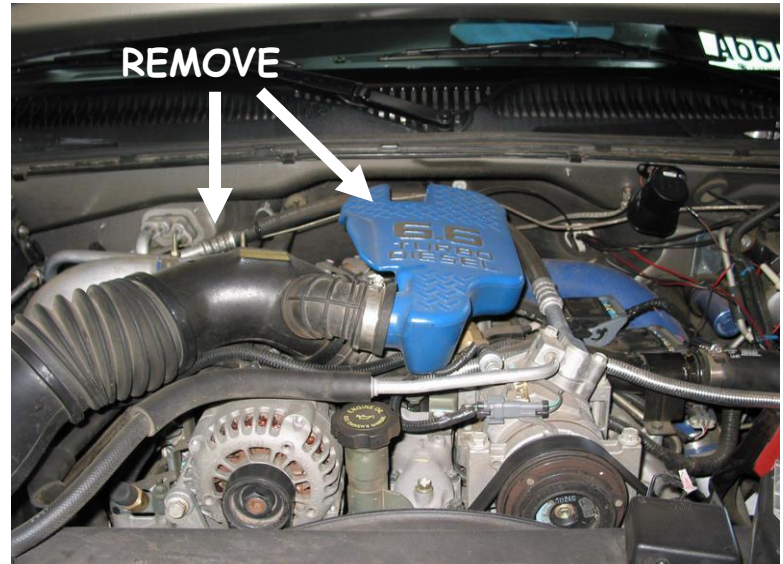

Using a 15mm socket, remove the four A/C compressor mounting bolts to move the A/C compressor for easy access to the turbo assembly. Be careful not to discharge the A/C line.



Using a 10mm socket, remove the three upper heat shield mounting bolts, and remove the heat shield protecting the exhaust turbine housing. Two of the bolts and the heat shield will be reused later.

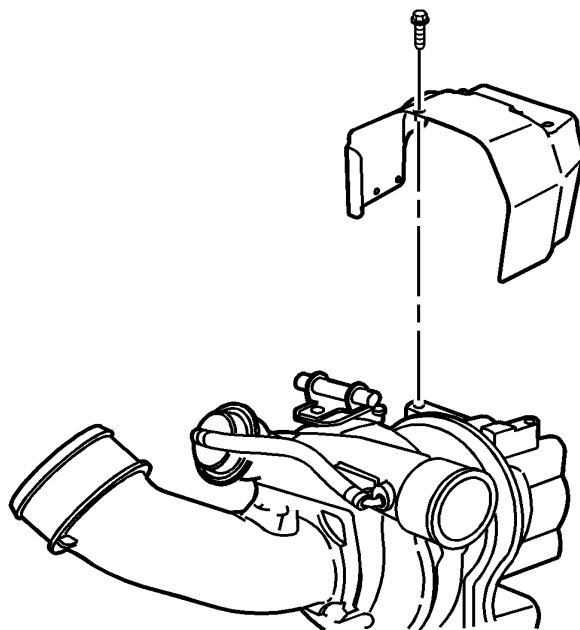

Using a 7/16" deep socket, remove the compressor outlet clamp and fold the silicone elbow back for access.

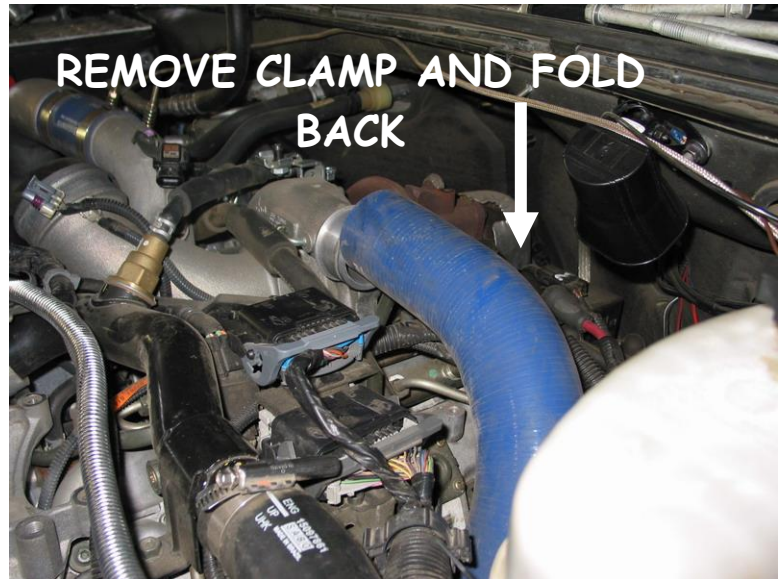

Remove the factory wastegate hose and breather hose using pliers. The breather hose runs from the drivers side valve cover to the passenger side valve cover under the wastegate actuator. Beneath the waste gate actuator you will find a "T" - Disconnect the breather hose at this point and push/pull the line to the side for easier access to the turbo.



Using a 10mm socket, remove the air intake heater connection, MAP sensor mounting bolt, and unplug the MAP sensor.

Using a 10mm socket with a swivel attachment, remove the three bolts holding the compressor inlet elbow to the compressor housing. Remove the inlet elbow.



Using a 13mm socket, remove the two nuts holding the transmission dipstick tube to the transmission bell housing and remove the tube.

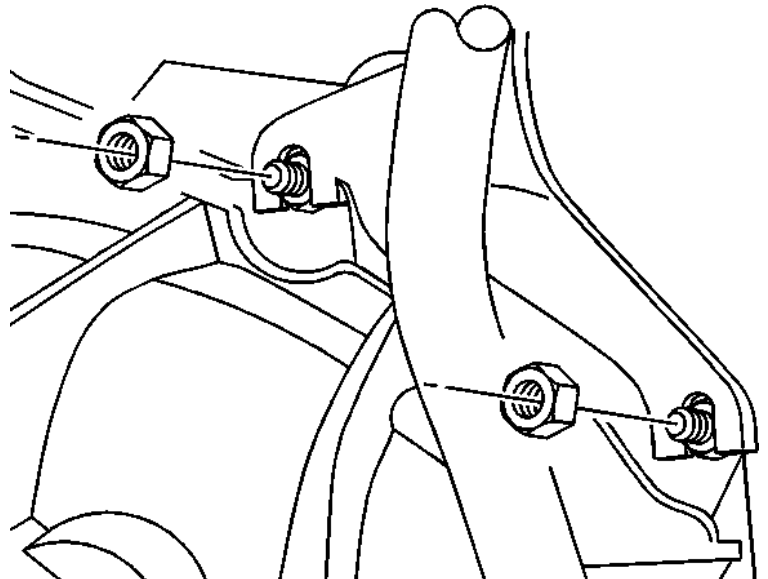

Using a 10mm wrench, remove the three rear heat shield mounting bolts. This will allow you to remove the heat shield protecting the down pipe.

To ease access to rear of the turbo, you can remove the transfer case vent.

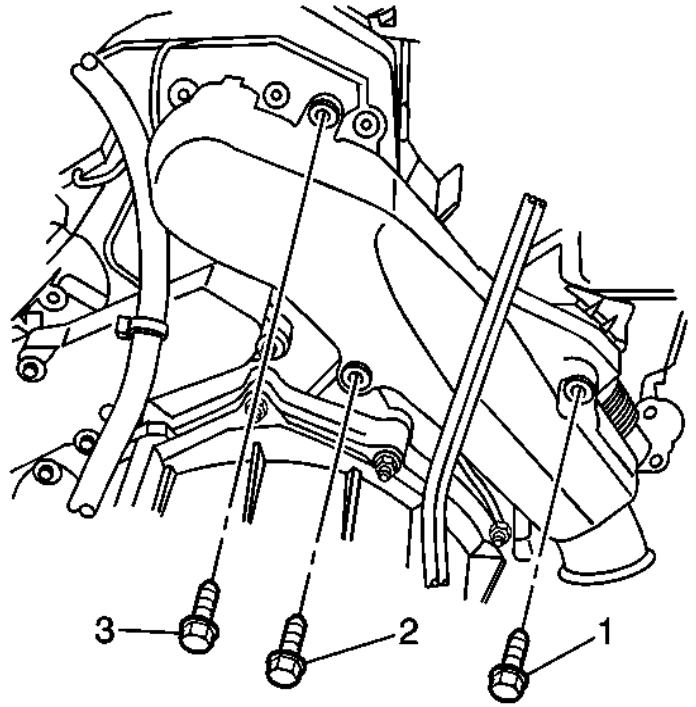

Using a 10mm wrench, remove the four drivers side feed pipe heat shield bolts: three from the top and one from the bottom.

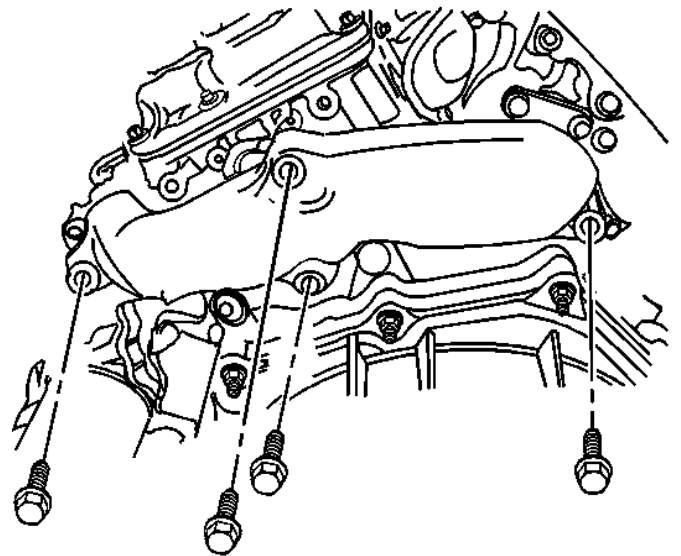

Using a 12mm - **12 point**, remove the four bolts that secure the down pipe to the turbo. As well, you will need to use a 14mm wrench to remove the remaining two nuts from the two studs.

Remove the support bracket that secures the down-pipe just above the marmon flange. You should now be able to remove the down-pipe.

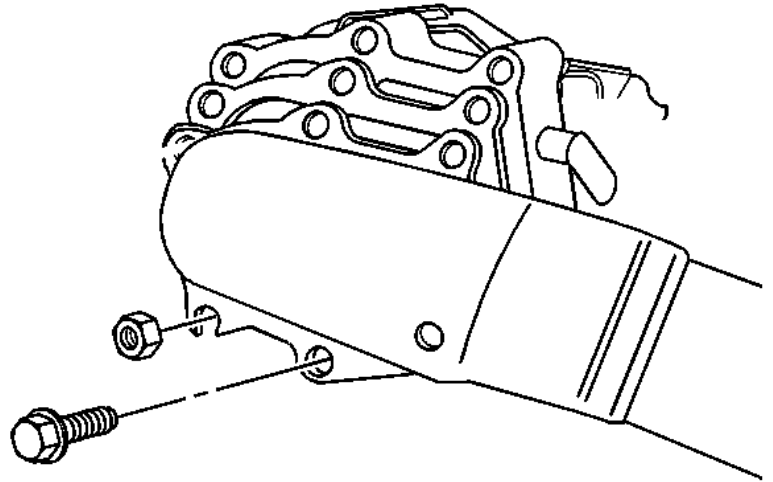

Remove the front curved section of the exhaust from the "4-bolt" flange to v-band clamp. This is located underneath the truck.

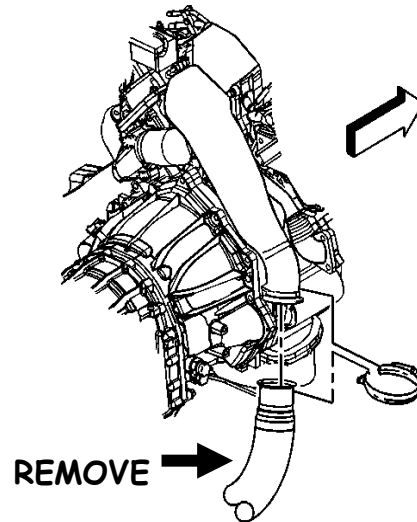

Using a 12mm - **12 point** socket, remove the six upper feed pipe bolts. Note that they may be extremely difficult to remove and may require heat to break them loose or penetrating oil.

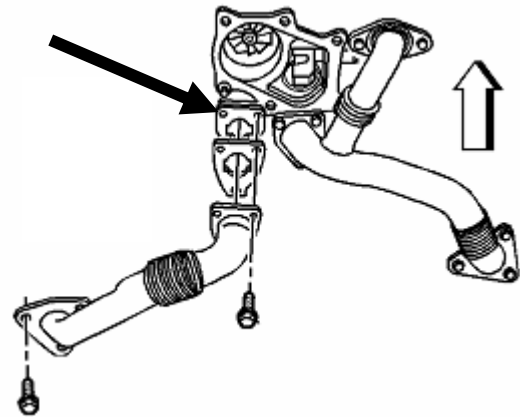

Using a 12mm deep socket, remove the oil drain flange nuts that secure the drain tube to the center of the block.

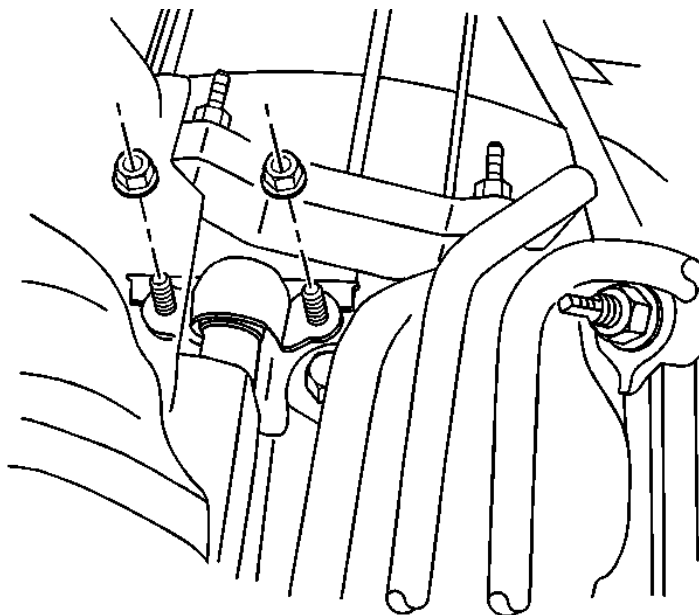

Remove the coolant supply lines from the brass check valve from the top of the engine.

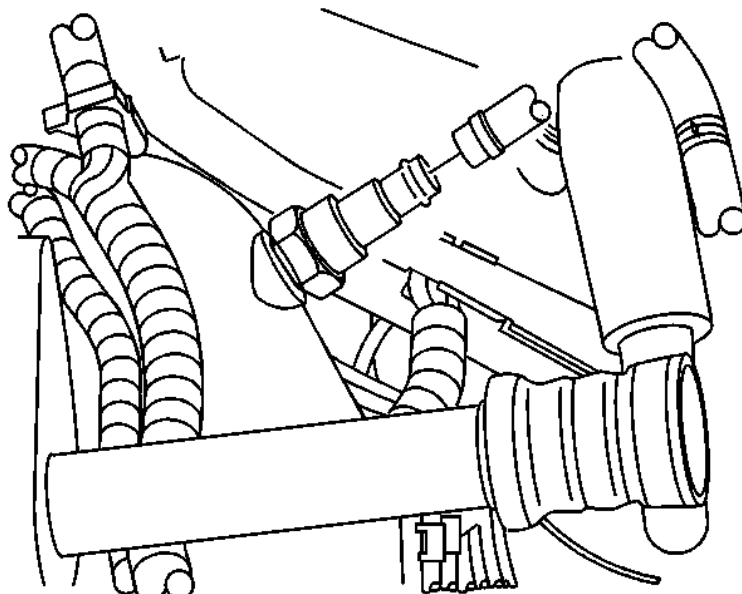

Remove the coolant outlet lines from the turbocharger.

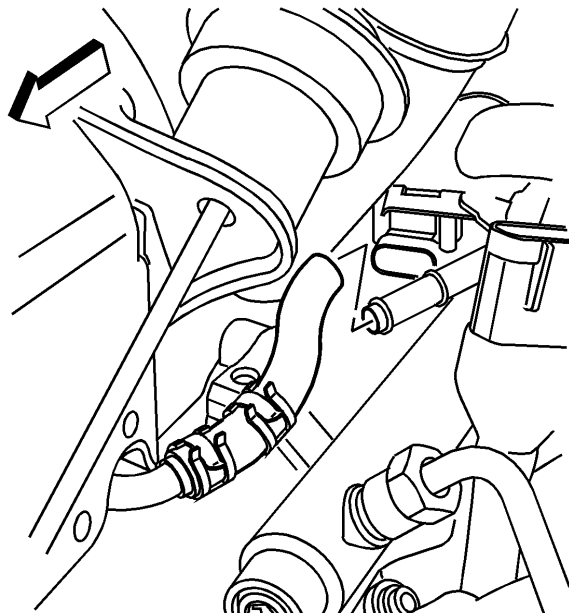

Using a 14mm socket, remove the oil supply line banjo bolt from the top of the turbo.

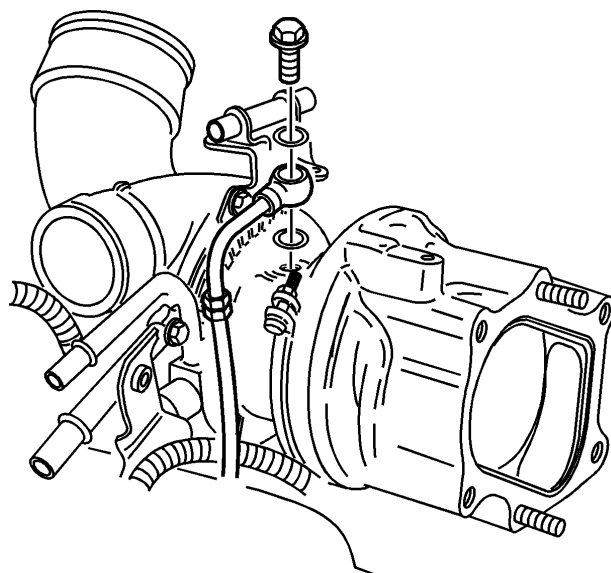

Using a Torx T55, loosen the Banjo bolt holding the lower coolant fitting in place to ease removal. You do not need to remove it.



Using an 18mm socket and extension, remove the three turbo assembly mounting bolts. These bolts secure the turbo assembly to the top of the block. Remove the turbo assembly, then the down pipe up through the engine compartment.

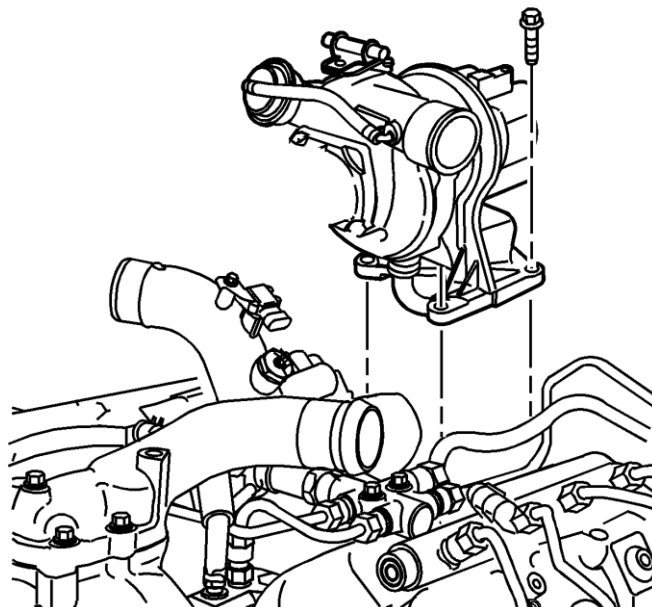

BD Engine Brake Inc.

Plant Address: 33541 MacLure Rd. Abbotsford, BC, Canada V2S 7W2

U.S. Shipping Address: 88-446 Harrison St, Sumas, WA 98295 U.S. Mailing Address: P.O. Box 231, Sumas, WA 98295

Phone: 604-853-6096 | Fax: 604-853-8749 | Internet: www.bd-power.com

Using a 14mm socket, remove the oil feed line banjo bolt from the center block.

You can now remove the remainder of the lower turbo coolant line that you loosened earlier from the turbo.

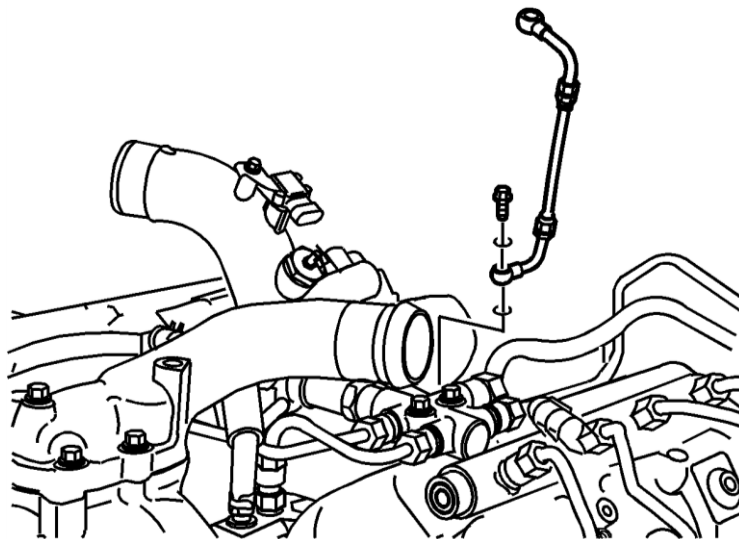

Turbo Installation

Install the **1462326** 12mm ORB plug into the factory turbo oil supply port. Be sure not to tighten the plug so much that the O-ring is distorted.

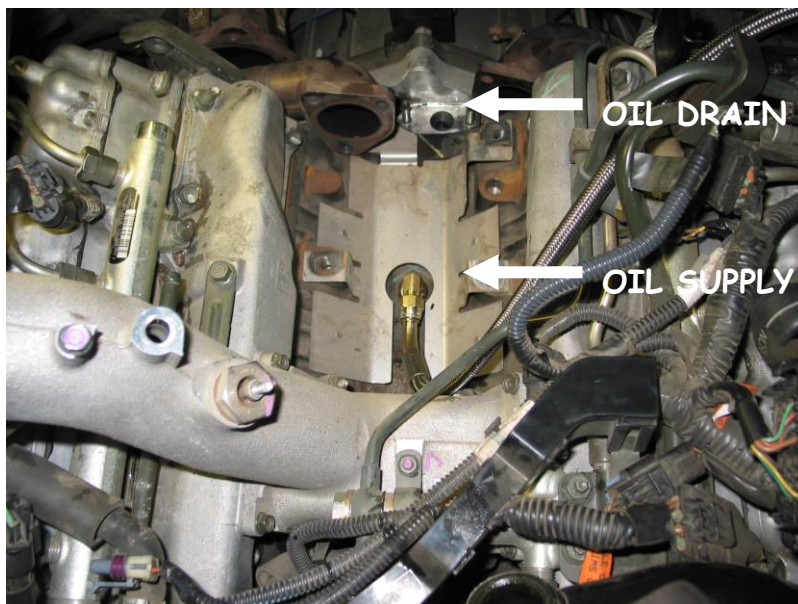

Install the four studs **1462430** into the turbo pedestal by screwing together two nuts onto the studs and tighten the assembly into the pedestal.

Install the turbo to the cast pedestal with the steel gasket and supplied nuts **1462441**, tighten with 15mm wrench.

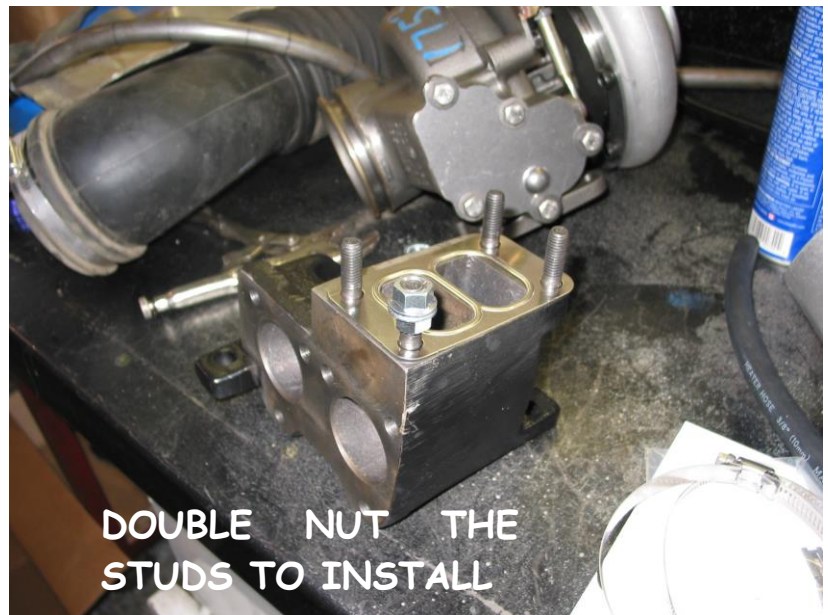

Sandwich the oil drain spacer **1462300** with a gasket on each side (#2405006 and the gasket in the turbo box). Place the oil drain on the bottom. Then Insert the two supplied studs #**1462301** thru the assembly and bolt the assembly to the turbo. Tighten using the 5/16 NF nuts.



There are three paper oil drain gaskets: two are the same for the upper spacer adapter and one that is different (#1462310) for the tube to engine to block connection.

BEFORE INSTALL INLET FITTING YOU MUST PRE-OIL THE TURBO USING 15W-40 OIL. IF THE FITTING IS PREVENTING THIS, YOU PRE LUBE THROUGH THE DRAIN.

BD Engine Brake Inc.

Plant Address: 33541 MacLure Rd. Abbotsford, BC, Canada V2S 7W2

U.S. Shipping Address: 88-446 Harrison St, Sumas, WA 98295 U.S. Mailing Address: P.O. Box 231, Sumas, WA 98295

Phone: 604-853-6096 | Fax: 604-853-8749 | Internet: www.bd-power.com

You may need to grind a 1/16" off of the factory drain tube flange to allow clearance between the flange and the compressor housing short head bolt.

Install the JIC – NPT **1462322** oil inlet fitting into the turbo (if it is not already) oil supply port facing in the same direction as the compressor outlet.

DO NOT USE TEFLON TAPE OR PIPE DOPE FOR SEALING PIPE THREAD. IF SEALANT IS REQUIRED, USE LOCTITE 592 p/n 59241.

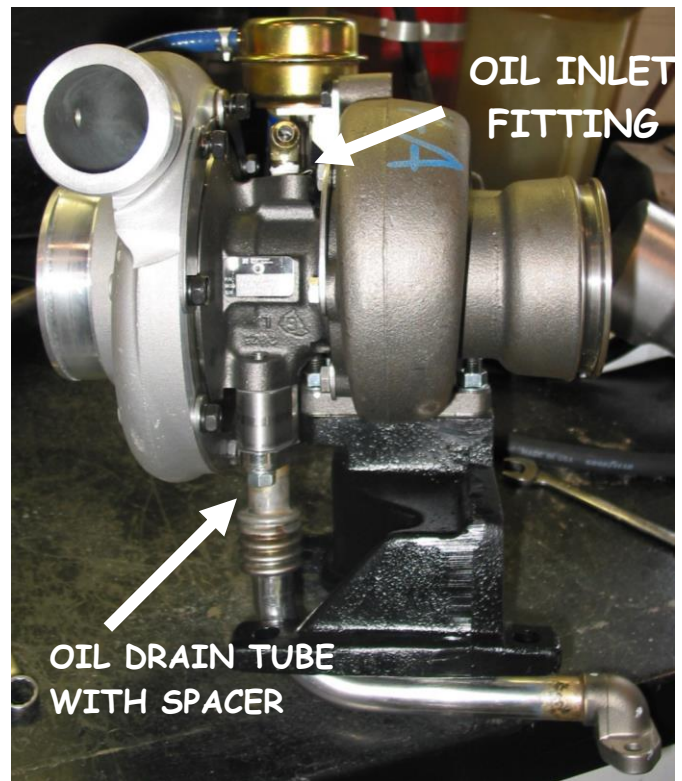

Install the oil drain gasket **1462310** on the two studs on the block. Pay attention to the proper orientation of the gasket. Remove the old gasket residue first before applying the new gasket.

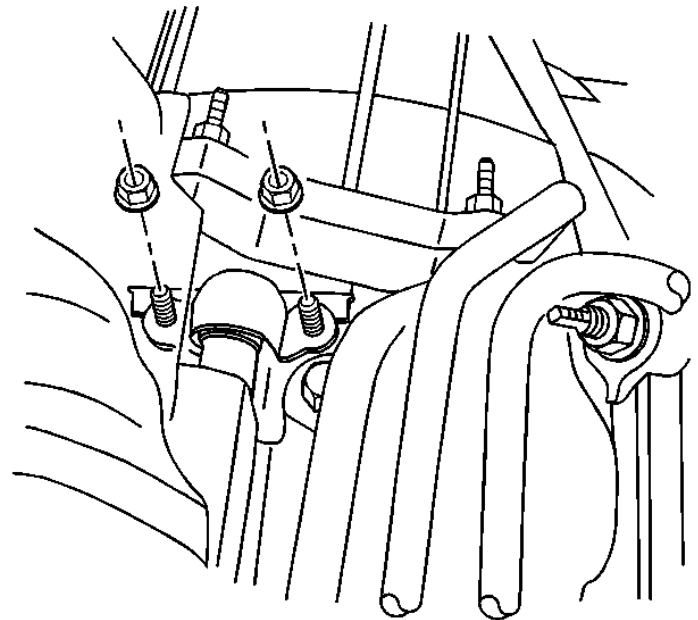

BD Engine Brake Inc.

Plant Address: 33541 MacLure Rd. Abbotsford, BC, Canada V2S 7W2

U.S. Shipping Address: 88-446 Harrison St, Sumas, WA 98295 U.S. Mailing Address: P.O. Box 231, Sumas, WA 98295

Phone: 604-853-6096 | Fax: 604-853-8749 | Internet: www.bd-power.com

Install the complete turbo assembly (pedestal and all) into the vehicle making sure to align the oil drain flange over the two studs at the rear of the engine. Tighten to **15 lbs-ft** of torque.

You will need to reuse the three bolts you removed earlier to secure the complete assembly down to the block. Leave the bolts loose until you fully re-install the two feed pipes.

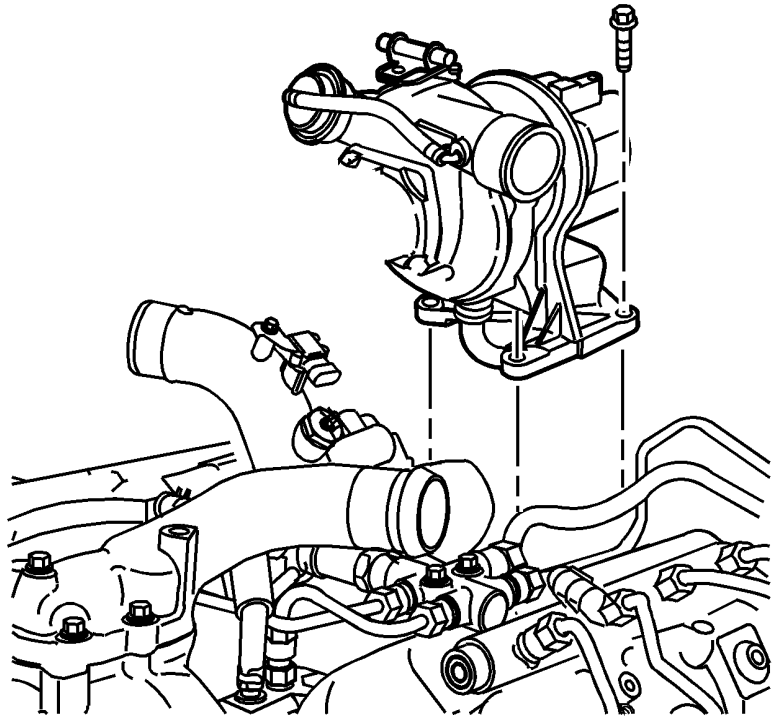

IF YOU HAVE BD'S NEW HIGH FLOW DURAMAX MANIFOLD, YOU SHOULD INSTALL IT NOW.

Re-install the feed pipes with the new supplied gaskets. You will need to reuse the old bolts. Make sure to use an anti-seize grease before assembling. Tighten to **39 lbs-ft** of torque.

Once tight, you can fully secure the three pedestal bolts to **80 lbs-ft** of torque.

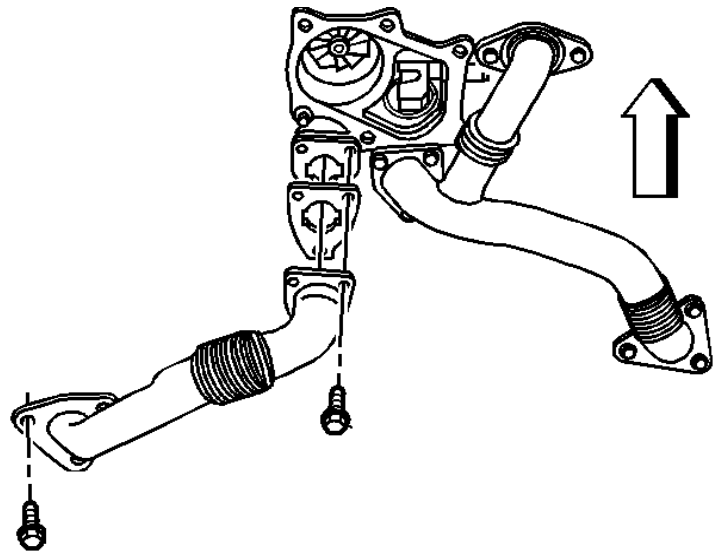

BD Engine Brake Inc.

Plant Address: 33541 MacLure Rd. Abbotsford, BC, Canada V2S 7W2

U.S. Shipping Address: 88-446 Harrison St, Sumas, WA 98295 U.S. Mailing Address: P.O. Box 231, Sumas, WA 98295

Phone: 604-853-6096 | Fax: 604-853-8749 | Internet: www.bd-power.com

Using a cutoff wheel, remove the upper stud protruding from the firewall for the heat shield on the passenger side of the engine compartment.

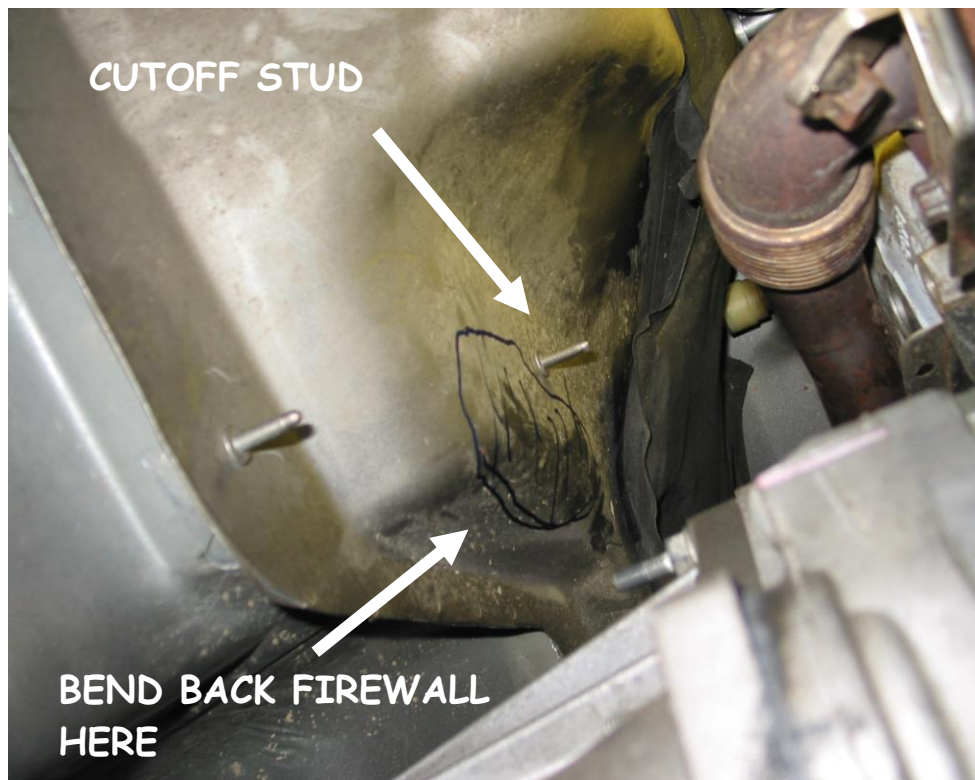
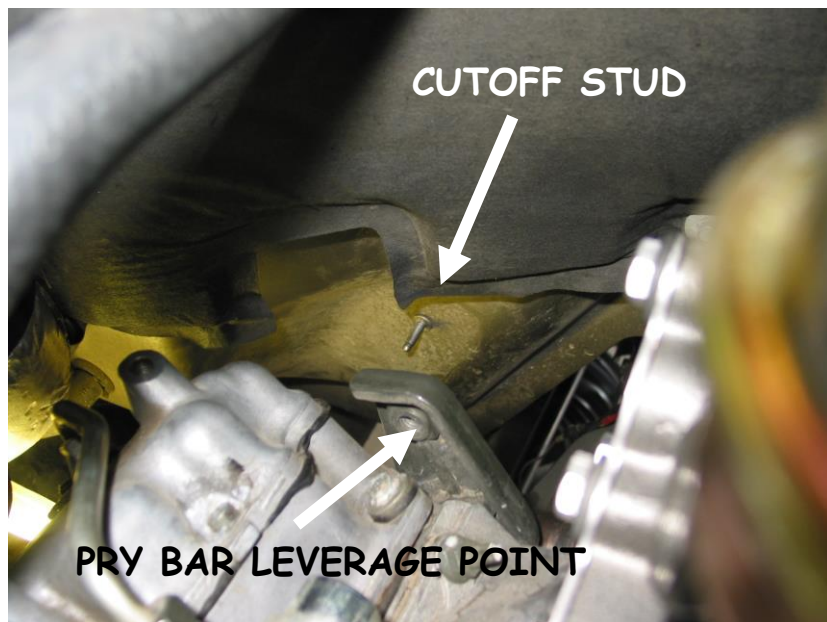

Using a larger pry bar, massage the firewall in the area shown, being careful not to pry against anything that will break. There is an engine-lifting bracket on the back of the passenger side head that works well as a leverage point. This is necessary to accommodate the larger down pipe.

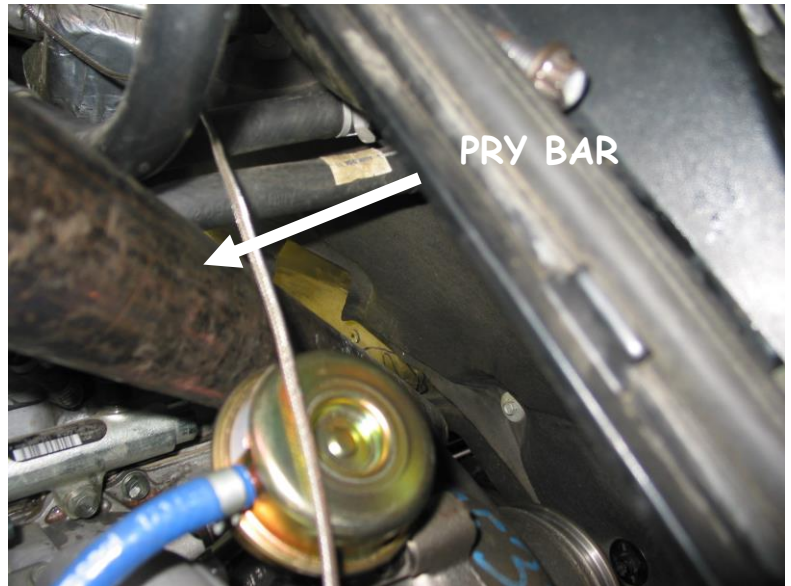

If a long pry bar does not work, you can use a small hydraulic bottle jack to adjust the firewall.

Cleanup loose paint and repaint the firewall to protect it from rust.

PLEASE NOTE THAT IT IS CRITICAL THAT SUFFICIENT ROOM IS MADE AVAILABLE FOR THE EXHAUST DOWN PIPE. FAILURE TO DO SO WILL CAUSE THE EXHAUST PIPES TO VIBRATE AGAINST THE FIREWALL.

Re-install the MAP sensor

Install the newly supplied coolant hose from the brass check valve to the return line. Use the new clamps and the hold down clamp as shown.

On 2001 trucks, the MAP sensor is located in a different position. You can use the nylon zip ties to secure the hose.

Re-install the compressor outlet silicone boot.



BD Engine Brake Inc.

Plant Address: 33541 MacLure Rd. Abbotsford, BC, Canada V2S 7W2

U.S. Shipping Address: 88-446 Harrison St, Sumas, WA 98295 U.S. Mailing Address: P.O. Box 231, Sumas, WA 98295

Phone: 604-853-6096 | Fax: 604-853-8749 | Internet: www.bd-power.com

Install the NEW DRIVER'S SIDE dipstick tube into the transmission **1462905**. It is easiest if you feed it up from the bottom of the vehicle and down into the transmission.

Loosen the bolt on the transmission bell housing, once the tube is in place secure it by retightening the bell housing bolt.

The dipstick tube may need slight tweaking as every truck is slightly different.

When installing the dip stick tube the Allison's alternate location, you will need to remove the plug and move it to the other side or OE location.

Wrap the down pipe **1462501** as shown. If you pre-moisten the exhaust wrap **1453514** it will shrink much tighter.

You will need to slip it up from underneath the vehicle.

Be sure not to wrap the flange area of the down pipe where the clamp is placed.

Use the provided V-band clamp **1405926** to secure it to the back of the turbo.

Insert the S/S header clamp into the locking clip all the way until the clamp material presses against the stop.

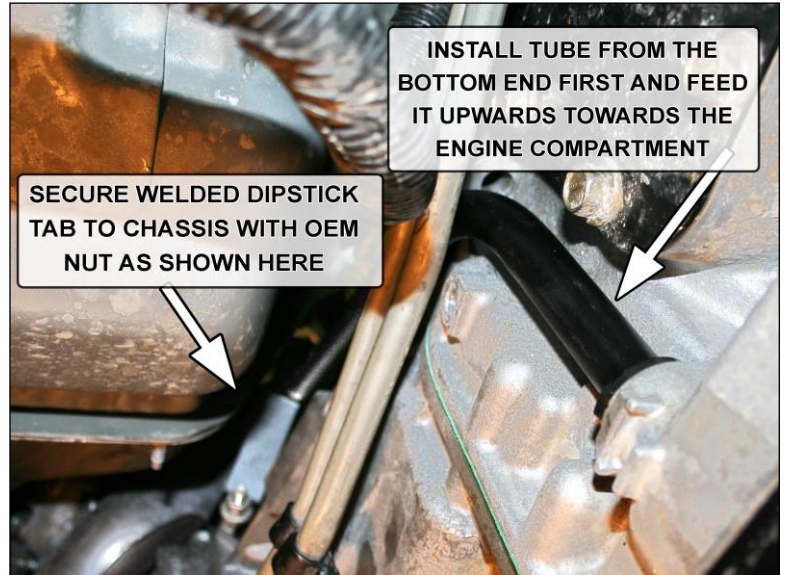

Wrap the clamp material around the pipe and insert it into the opposite end. Pull tight and hammer down the locking tabs.

Pull tight and hammer down locking tabs.

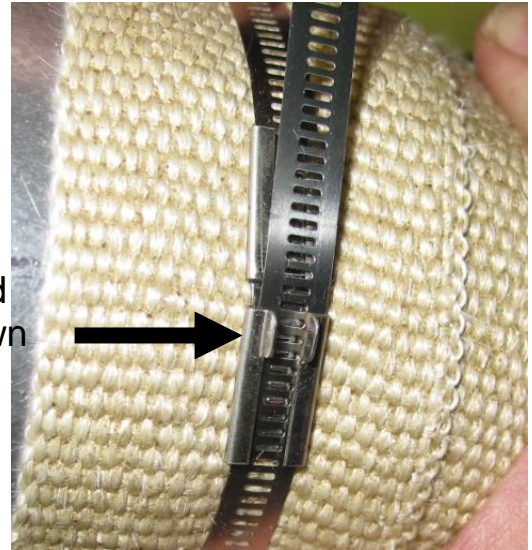

Install the two pieces of silver heat shield **1040142** to further insulate the down pipe from the firewall; hold it in place with the stainless wire provided **1459113**.

Modify and Re-install your exhaust to fit to the new down pipe.

Note if you have an exhaust brake installed you will need to weld the down-pipe to the exhaust connection. The stainless clamp will not hold enough back pressure.

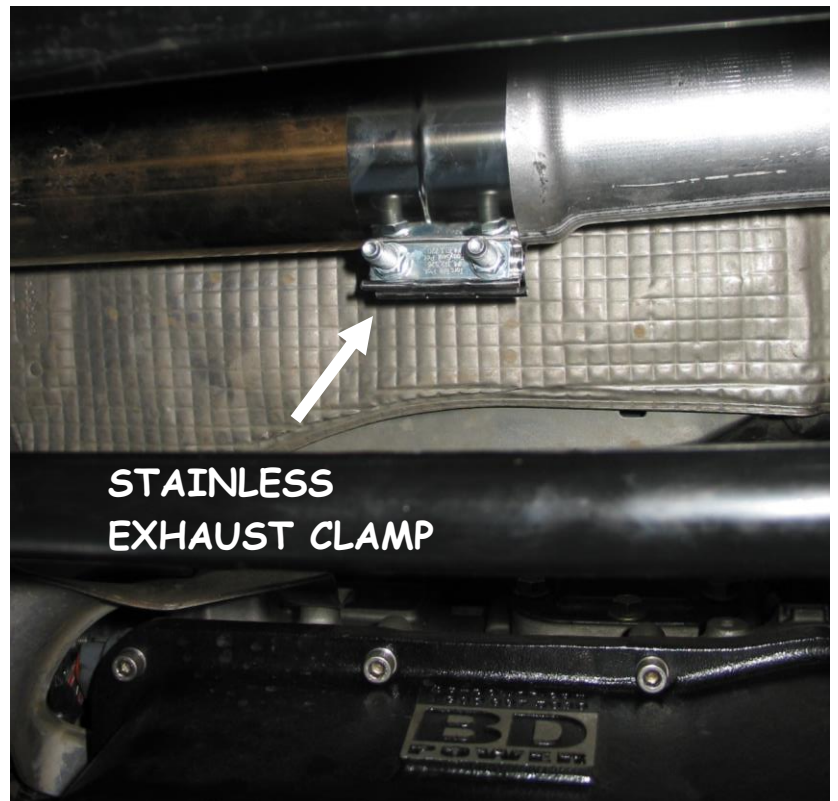

BD Engine Brake Inc.

Plant Address: 33541 MacLure Rd. Abbotsford, BC, Canada V2S 7W2

U.S. Shipping Address: 88-446 Harrison St, Sumas, WA 98295 U.S. Mailing Address: P.O. Box 231, Sumas, WA 98295

Phone: 604-853-6096 | Fax: 604-853-8749 | Internet: www.bd-power.com

Thread the upper oil line **1462325** into the exit/output of the check valve **1462327**. Thread the lower oil line **1462324** into the entry/input of the oil line. Both these threads are pipe threads, so do not use Teflon tape. A very small amount of liquid pipe dope may be used.

With the line assembled, oil should be able to flow to the turbocharger but should not be able to drain back.

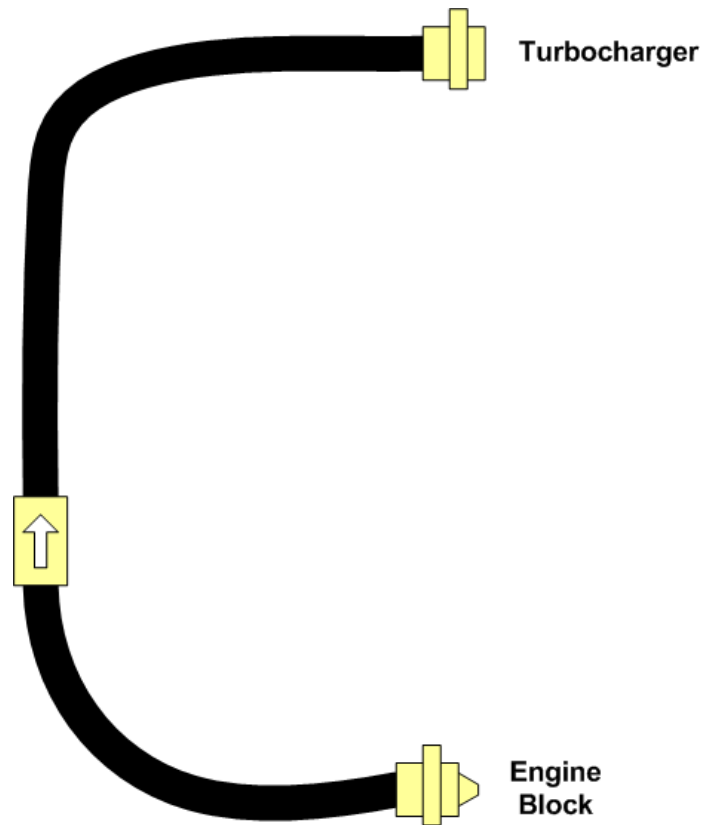

With the vehicle on the hoist, locate the oil filter/cooler assembly. Just to the right of the assembly on the block you will be able to see a 19mm bolt that leads to the engine oil rail. You will need to remove this bolt.

Once the bolt is removed, clean the taper area and thread in the M14x1.5 adapter **1462323**. Be sure to remove the outer washer that holds the O-ring in place. Also, lubricate the O-ring before tightening.



You can now thread the feed line onto the adapter and route the complete auxiliary line up towards the top of the engine. Route the line away from the exhaust manifold, charge pipe and the steering shaft.

Secure the line just above the frame rail to the hard fuel line. Ensure that everything is secure and will not vibrate.

BD Engine Brake Inc.

Plant Address: 33541 MacLure Rd. Abbotsford, BC, Canada V2S 7W2

U.S. Shipping Address: 88-446 Harrison St, Sumas, WA 98295 U.S. Mailing Address: P.O. Box 231, Sumas, WA 98295

Phone: 604-853-6096 | Fax: 604-853-8749 | Internet: www.bd-power.com

Before connecting the turbo oil feed line, pre-fill the line with oil. Once you have filled the line with oil you can connect the line to the turbo.

Install the upper heat shield support bracket **1462101** on the two upper compressor housing bolts. Make sure the bracket is level and the bolts are installed tight.



Modify the factory heat shield with a cutoff wheel as shown, stay to the outside of the two spot welds. Install it with two of the three original mounting bolts.

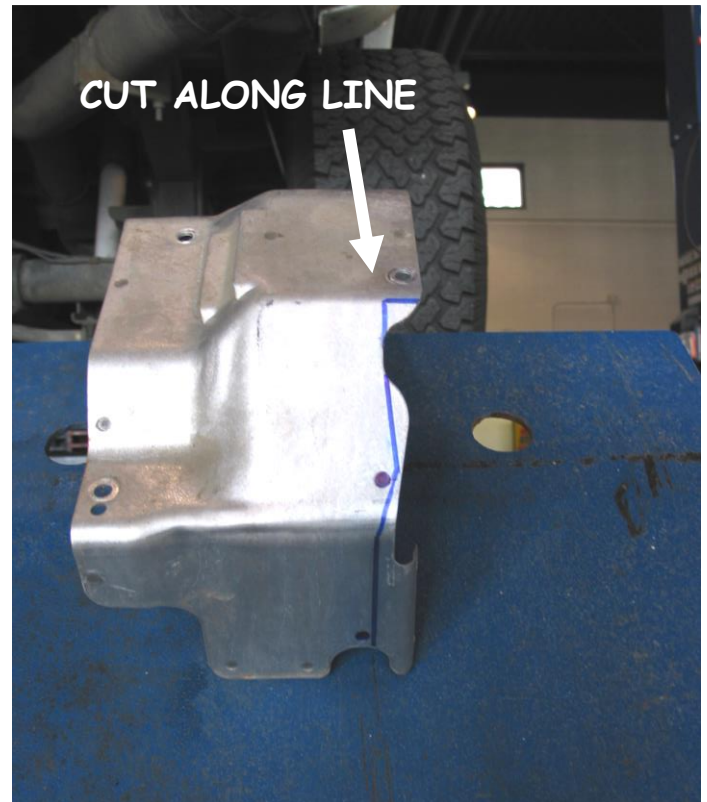

BD Engine Brake Inc.

Plant Address: 33541 MacLure Rd. Abbotsford, BC, Canada V2S 7W2

U.S. Shipping Address: 88-446 Harrison St, Sumas, WA 98295 U.S. Mailing Address: P.O. Box 231, Sumas, WA 98295

Phone: 604-853-6096 | Fax: 604-853-8749 | Internet: www.bd-power.com

You can now install the,

- compressor outlet adapter #1406211
- O-Ring 1453251
- Clamp 1452225

Lubricate the o-ring before use.

Finally tighten the factory CAC boot and intercooler pipe to the turbo.



Install the powder coated air inlet elbow **1462601P** and plastic air inlet pipes. Use the provided 4" clamps **1453701** and silicone hose **1405222** (cut hose to 2 ¼" long) for the elbow-to-turbo inlet connection.

When installing the inlet elbow, the fit will be very tight. It is recommended to install the silicone hose and clamp to the elbow first, and then install it to the inlet of the turbo.

IF YOU ARE USING THE AFE TORQUE TUBE STAGE II KIT, YOU WILL HAVE TO CUT A SECTION OFF OF THE SMALL END OF THE ELBOW TO ACCOMMODATE THIS KIT. IF YOU HAVE THE FACTORY AIRBOX TUBE YOU WILL NOT NEED TO CUT THIS PIPE.

Reconnect the pre heater and map sensor plugs. Re-install the breather hose to the "T" on the passenger side. Re-mount the A/C compressor and hook up the high pressure cutout and A/C clutch electrical connectors. You can use an extra piece of reflective heat shielding to protect the A/C line that runs over top of the turbo. Re-install the belt and refill the cooling system. Re-install the intake silencer plenum - note that 2001 year vehicles will not be able to reuse the plastic intake silencer.

BEFORE STARTING THE ENGINE REMOVE THE OIL FEED LINE FROM THE TURBO AND PRE-FILL THE FEED LINE.

Reprogram the vehicle's radio stations and settings if desired.

Road Test

Before performing a road test, be sure that all clamps are tight and that nothing is rubbing against the engine.

BD Engine Brake Inc.

Plant Address: 33541 MacLure Rd. Abbotsford, BC, Canada V2S 7W2

U.S. Shipping Address: 88-446 Harrison St, Sumas, WA 98295 U.S. Mailing Address: P.O. Box 231, Sumas, WA 98295

Phone: 604-853-6096 | Fax: 604-853-8749 | Internet: www.bd-power.com

You will need to check for sufficient room between the down pipe and the firewall. To do this, accelerate the vehicle in reverse turning both left and right. Then accelerate the vehicle forward while turning left and right. If any unusual noise is heard, you may have to re-adjust the down pipe and firewall.

On the test drive, ensure that there are no boost leaks, or worse, any exhaust leaks.

Once the test drive has been successful, you will need to re-tighten all of the exhaust and intake bolts.

Please note the turbocharger should not exceed 40psi of boost pressure. If you are experiencing low boost, you can adjust the wastegate (shortening the rod) to increase the waste gate opening pressure.

IMPORTANT When idled for any length of time some oil may leak from the turbo. If the performance/boost is satisfactory and the wheel is not touching the housing (There will be some small movement), the excess oil is not a concern. Simply wipe with a clean cotton cloth and continue use.