



*DOWNLOAD ENHANCED
INSTALL MANUALS AT*



EGR COOLER MUST BE REMOVED (NOT CARB/EPA LEGAL)

BD FORD 6.0L PERFORMANCE

EXHAUST UP-PIPE

Installation Instructions







Application List		
Ford Powerstroke 2003-04	6.0L	1043915
Ford Powerstroke 2005-07	6.0L	1043916

PLEASE READ ALL INSTRUCTIONS BEFORE INSTALLATION

UNLESS AN EO# IS LISTED, THIS PRODUCT IS LEGAL IN CALIFORNIA FOR RACING VEHICLES ONLY, WHICH MAY NEVER BE USED UPON A HIGHWAY.

KITCONTENTS:

Please check to make sure that you have all the parts listed in this kit before you start the disassembly of your truck.

<i>1043915 Kit Contents</i>			
1403124	1452225	1403126	
			
<i>Y Casting Ductile Iron</i>	<i>Clamp, V- Band</i>	<i>Driver side up pipe</i>	
Qty: 1	Qty: 2	Qty: 1	
1900014	1900013	1403127	
			
<i>Flange nut</i>	<i>Flange bolt 60 mm Long</i>	<i>Passenger side up-pipe</i>	
Qty: 4	Qty: 4	Qty: 1	
5C3Z-9F460-A	1900037	FT-0127135	FT-11509452
			
<i>Heat shield Ford 6L</i>	<i>M6x12mm Bolt</i>	<i>M10x16mm Bolt</i>	<i>M10 Washer</i>
Qty: 1	Qty: 1	Qty: 1	Qty: 1





BD Engine Brake Inc.

Plant Address: 33541 MacLure Rd. Abbotsford, BC, Canada V2S 7W2

U.S. Shipping Address: 88-446 Harrison St, Sumas, WA 98295 U.S. Mailing Address: P.O. Box 231, Sumas, WA 98295

Phone: 604-853-6096 | Fax: 604-853-8749 | Internet: www.bd-power.com

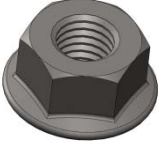
1043916 Kit Contents

1403124		1452225	1403126
			
Y Casting Ductile Iron		Clamp, V- Band	Driver side Up pipe
Qty: 1		Qty: 2	Qty: 1
1900014	1900013	1403127	
			
Flange nut	Flange bolt 60 mm Long	Passenger Side up-pipe	
Qty: 4	Qty: 4	Qty: 1	

Factory Replacement Parts

Description

Part

Ford 6.0L Turbo Inlet Clamp

Ford Part # F81Z8287EA

BD Engine Brake Inc.

Plant Address: 33541 MacLure Rd. Abbotsford, BC, Canada V2S 7W2

U.S. Shipping Address: 88-446 Harrison St, Sumas, WA 98295 U.S. Mailing Address: P.O. Box 231, Sumas, WA 98295

Phone: 604-853-6096 | Fax: 604-853-8749 | Internet: www.bd-power.com

Removal

1. Position vehicle on a hoist; chock wheels if necessary to prevent vehicle from rolling. Disconnect the Negative terminals on both batteries.
2. Remove the turbocharger assembly. Please follow manufacturer's instructions.
3. Remove the fuel injector control module. Please follow manufacturer's instructions.

4. Remove the retaining nuts and FICM bracket from driver side valve cover.

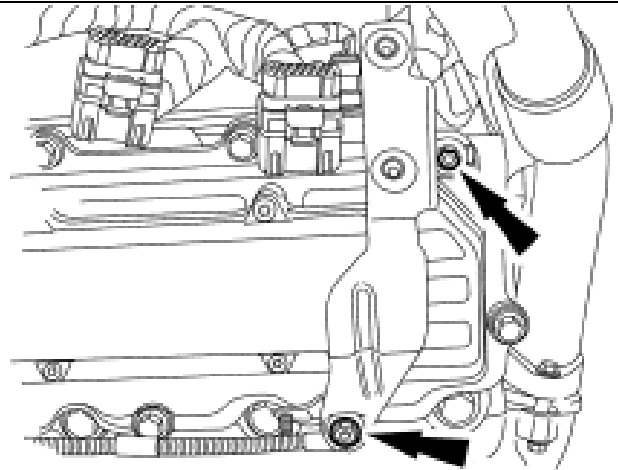

5. Remove the turbocharger inlet Y-pipe- to turbo inlet clamp.

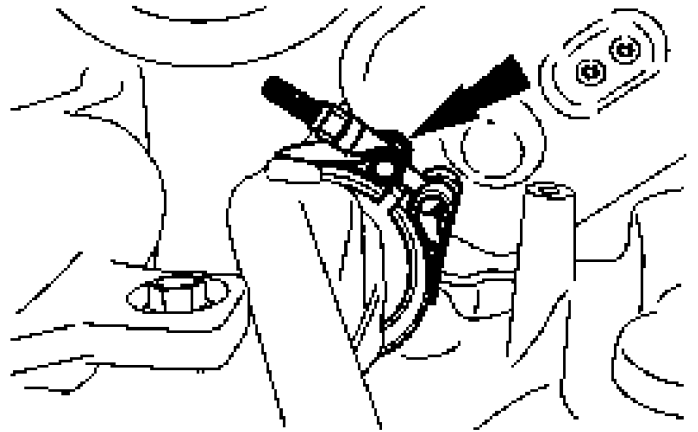

6. Remove the driver side turbocharger inlet Y-pipe-to exhaust manifold nuts.

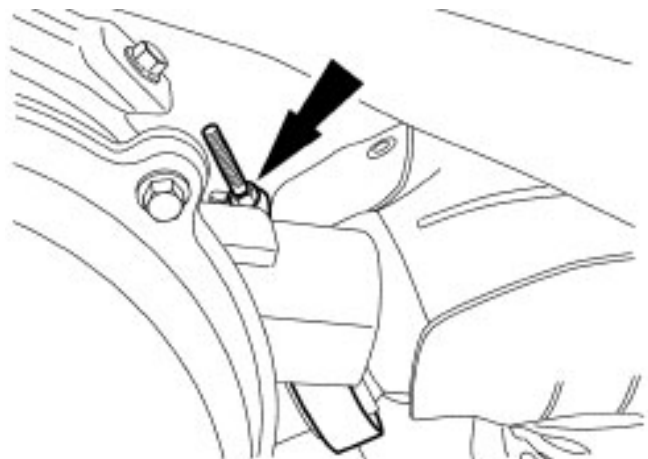

BD Engine Brake Inc.

Plant Address: 33541 MacLure Rd. Abbotsford, BC, Canada V2S 7W2

U.S. Shipping Address: 88-446 Harrison St, Sumas, WA 98295 U.S. Mailing Address: P.O. Box 231, Sumas, WA 98295

Phone: 604-853-6096 | Fax: 604-853-8749 | Internet: www.bd-power.com

7. Remove the passenger side turbocharger inlet Y-pipe-to exhaust manifold nuts.

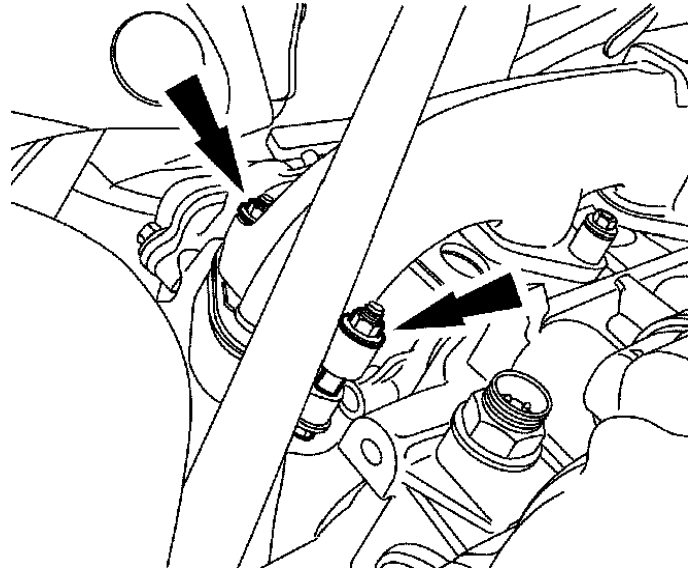

8. Position the turbocharger inlet Y-pipe to gain access to the turbocharger inlet Y-pipe joint. Remove the bolts, separate the turbocharger inlet Y pipe joint and remove the gasket. Remove the two parts of the turbocharger inlet Y-pipe.

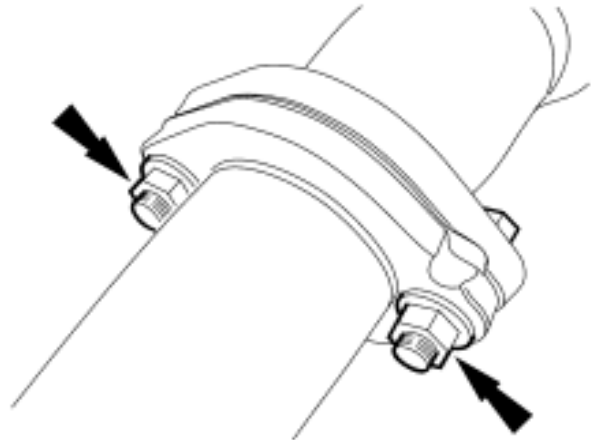

NOTE: These bolts may be easier to access if the inner fender liner is removed.

BD Engine Brake Inc.

Plant Address: 33541 MacLure Rd. Abbotsford, BC, Canada V2S 7W2

U.S. Shipping Address: 88-446 Harrison St, Sumas, WA 98295 U.S. Mailing Address: P.O. Box 231, Sumas, WA 98295

Phone: 604-853-6096 | Fax: 604-853-8749 | Internet: www.bd-power.com

Installation

Install Notes:

- ◆ When installing the turbo inlet Y-pipe into the vehicle, do not bend or twist the flex bellows.
- ◆ Only tighten the turbocharger inlet Y-pipe fastener with hand tools.

1. If you have a 2003-04 vehicle install the supplied heatshield.

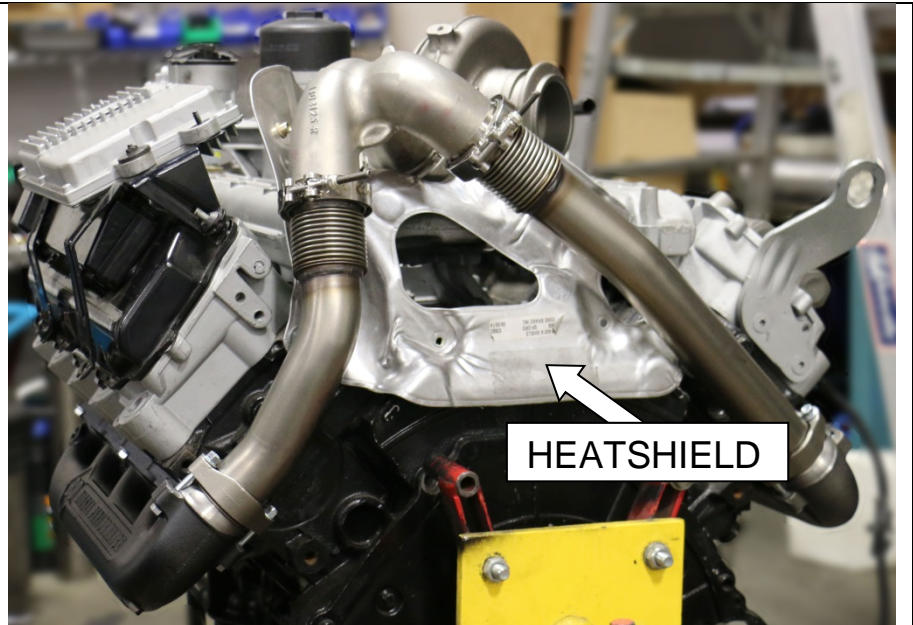

2. Assemble the BD passenger side up-pipe 1403127 onto the BD Y-collector 1403124 using the supplied V-clamp 1452225. Leave loose to allow movement.

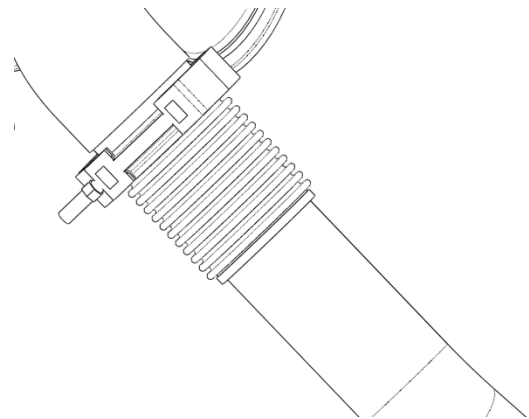

3. Maneuver the pipe assembly in to the vehicle and place the Y-collector in to the turbo inlet and reinstall OEM clamp. Leave loose to allow movement.

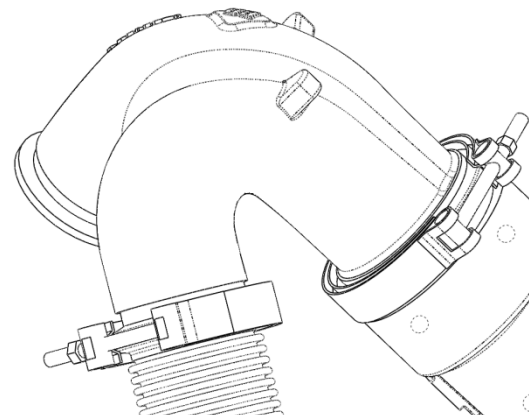

BD Engine Brake Inc.

Plant Address: 33541 MacLure Rd. Abbotsford, BC, Canada V2S 7W2

U.S. Shipping Address: 88-446 Harrison St, Sumas, WA 98295 U.S. Mailing Address: P.O. Box 231, Sumas, WA 98295

Phone: 604-853-6096 | Fax: 604-853-8749 | Internet: www.bd-power.com

4. Install driver side up-pipe 1403126 to the Y collector 1403124 using supplied V clamp 1452225.
Leave loose to allow movement.

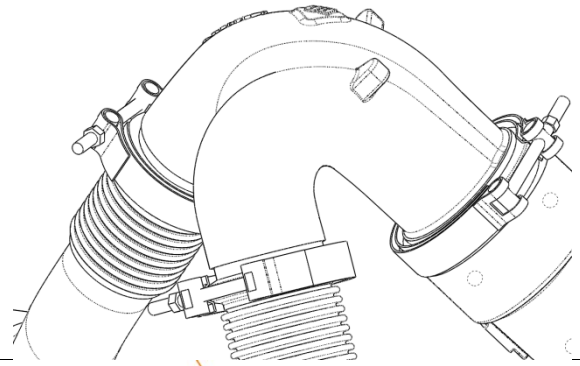

5. Connect the passenger side up-pipe to the passenger side manifold using supplied bolt 1900013 and nut 1900014.
Tighten bolts to 27Nm (20 lb-ft).

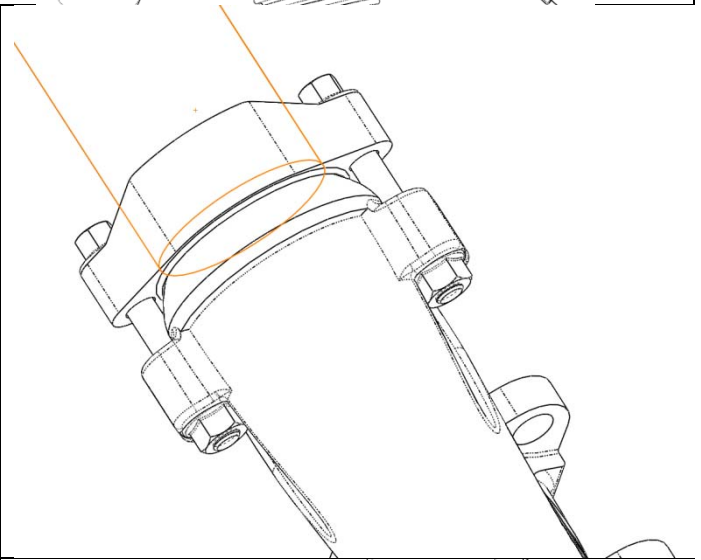

6. Connect the driver side up-pipe 1403126 to the driver side manifold using supplied bolt 1900013 and nut 1900014.
Tighten bolts to 27 Nm (20 lb-ft).

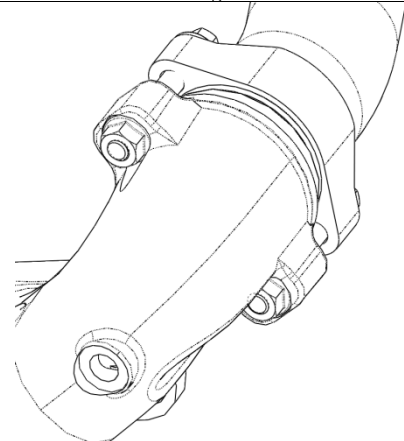

7. Tighten both driver and passenger side up-pipe V-band clamps (1452225) to Y-collector using socket.
Torque to 12 Nm (9 ft-lb).

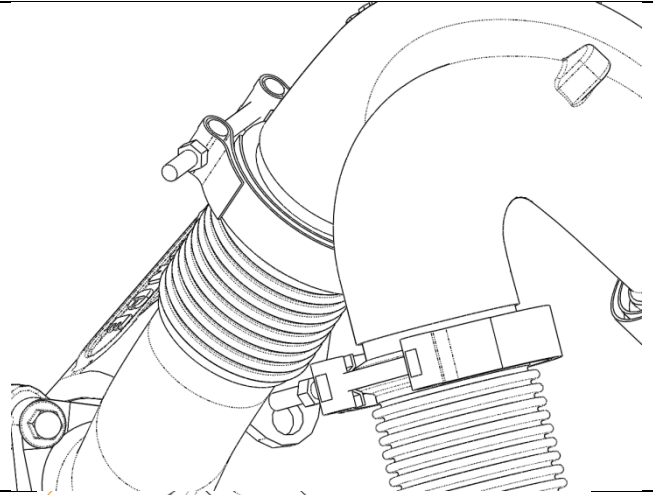

8. Tighten the v-band clamp (F81Z8287EA) to Y-collector to turbine hosing using 7/16 socket). Torque to 12 Nm (9lb-ft).

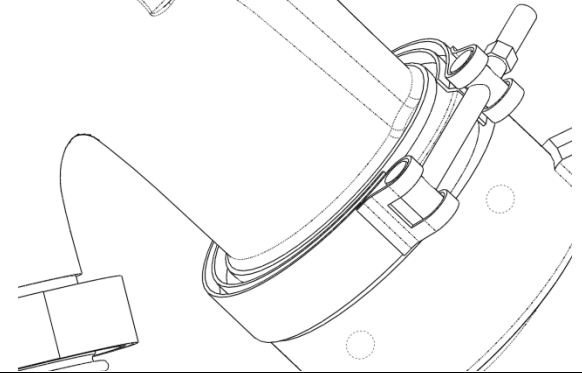

9. Reinstall FICM (Follow OE Instructions)

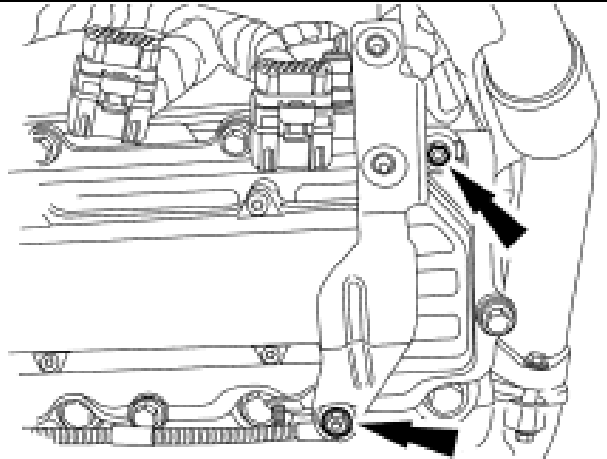

10. Reinstall Turbo (Follow OE Instructions)

11. Start the engine and check the system for leaks. Installation is complete.