



**DOWNLOAD
ENHANCED INSTALL
MANUALS AT
dieselperformance.com**

This kit was designed to fit 2001-04 LB7 non-California trucks.

Other applications for this kit are to be considered RACE ONLY and not to be used on public/offroad.

For these applications you will require:

- Aftermarket delete tuner
- Aftermarket downpipe (Diamond Eye, MBRP)
- EGR Delete Kit, not block off plate

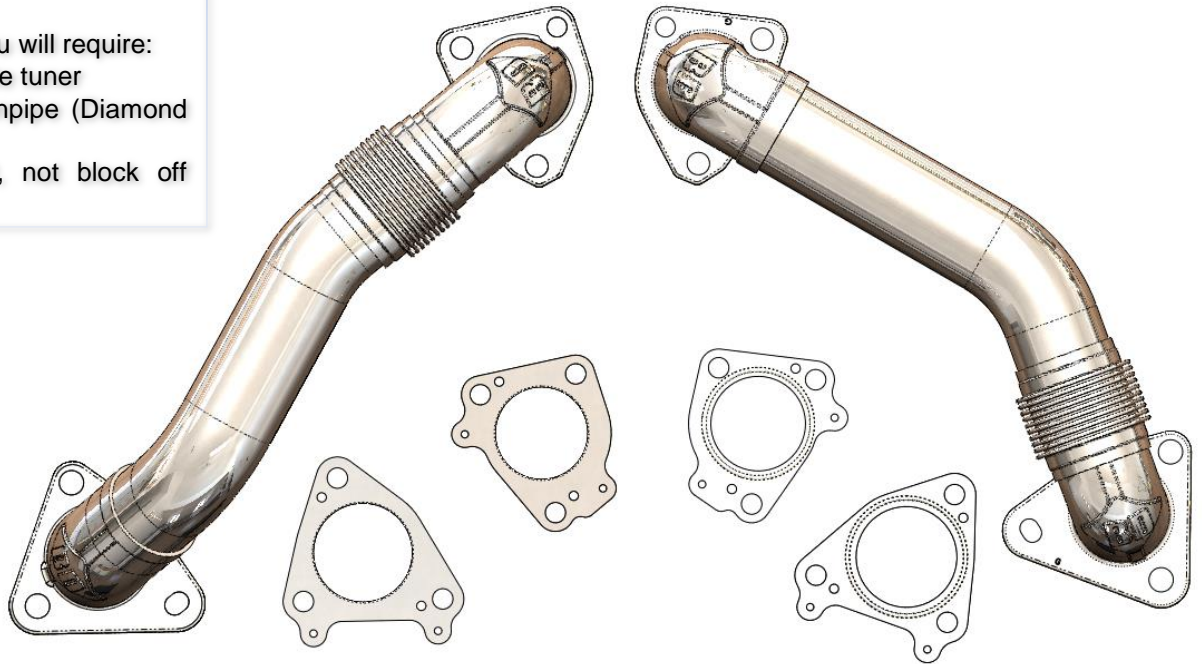



Up Pipe Kit for Duramax 6.6L
Duramax 2001-04 Models (Non CA)
Duramax 2004.5-13 Non Emissions LEGAL



P/N# 1043800

PLEASE READ ALL INSTRUCTIONS BEFORE INSTALLATION

KIT CONTENTS:

Please check to make sure that you have all the parts listed in this kit **before** you start the disassembly of your truck.

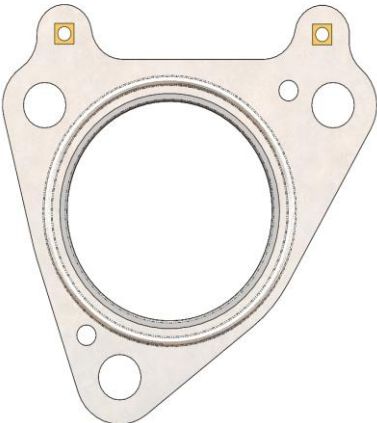
1403801	1453504	1403802
		
<i>Up Pipe Driver Side</i> Qty: 1	<i>Zip Tie</i> Qty: 2	<i>Up Pipe Passenger Side</i> Qty: 1

1403801-G1	1403801-G2	1453514
		
<i>Exhaust Manifold Gasket</i> <i>(0.062 Thickness)</i> Qty: 2	<i>Turbocharger Gasket</i> <i>(0.062 Thickness)</i> Qty: 2	<i>Exhaust Wrap</i> Qty: 1

Required Tools

- 10/12/13/15/16mm socket & Wrench
- 12 Point Metric Sockets
- 7/16" / 9/16" deep socket
- Pry Bar
- Plastic Scraper
- Torque Wrench
- Side Cutter

Additional Items

2001-2004 (Non-California) Applications

For these vehicles you will need the following that are not provided in this kit,

- Aftermarket Downpipe
 - Diamond Eye # 321055
 - MBRP # GM8425

2004.5-2013 Applications (Not Emissions Legal)

- Aftermarket Downpipe
 - Diamond Eye # 321056
 - MBRP # GM8424

These applications will require an EGR Cooler Removal Kit (Not a blocker plate) and an EGR Delete tuner.

It is also suggested that you purchased a set of Up pipe bolts from GM prior to the installation. GM Part# 97227612 / 11611132.

CRITICAL NOTE

There is a very good chance that you will need to modify your performance downpipe. A vice and ball peen hammer are required. Do not proceed if you do not feel comfortable doing this.

We have included thicker gaskets to aid in generating clearances between the uppipes and the engine block. It is important that these are used.

Removal

VEHICLE SHOULD BE SAFELY SECURED BEFORE INSTALLATION.

1. With the vehicle in PARK and the emergency brake set, position it on a 2 post hoist.
2. Remove the transmission. (This is optional but does aid in removal).
3. Remove passenger side wheel and wheel well liner.



Passenger side up-Pipe Removal and installation

1. Remove the exhaust gas recirculation (EGR cooler). Follow instructions on your EGR cooler delete.
2. Remove the turbocharger upper heat shield bolts and heat shield.

On later model year trucks you may need to remove the glow plug controller.

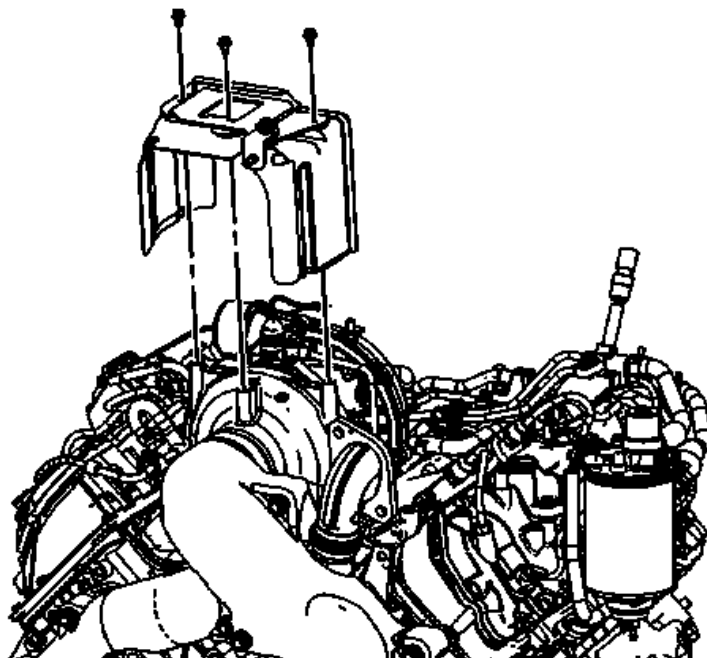

3. Loosen turbocharger exhaust down pipe turbocharger clamp nut (#1).

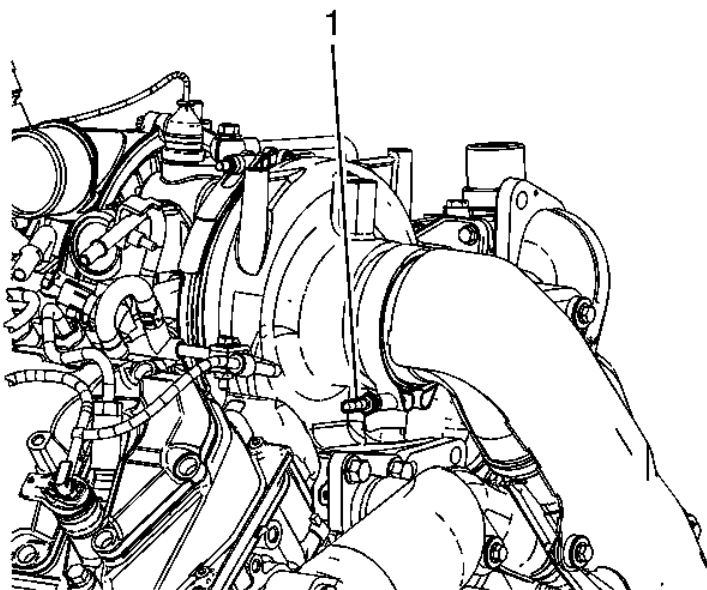

BD Engine Brake Inc.

Plant Address: 33541 MacLure Rd. Abbotsford, BC, Canada V2S 7W2

U.S. Shipping Address: 88-446 Harrison St, Sumas, WA 98295 U.S. Mailing Address: P.O. Box 231, Sumas, WA 98295

Phone: 604-853-6096 | Fax: 604-853-8749 | Internet: www.bd-power.com

4. Remove turbocharger exhaust pipe to bracket bolt (#1). Remove the turbocharger exhaust pipe. If this is the OEM pipe you will discard as you will need an aftermarket one.

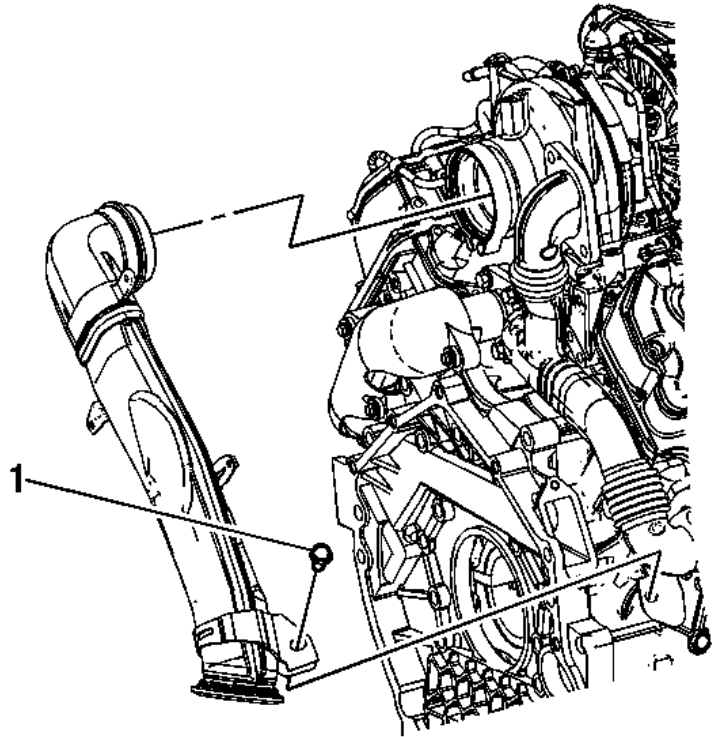

5. Through the wheelhouse opening, remove the transmission fluid fill tube to the bell housing.

Position the transmission fluid fill tube to the side of the vehicle.

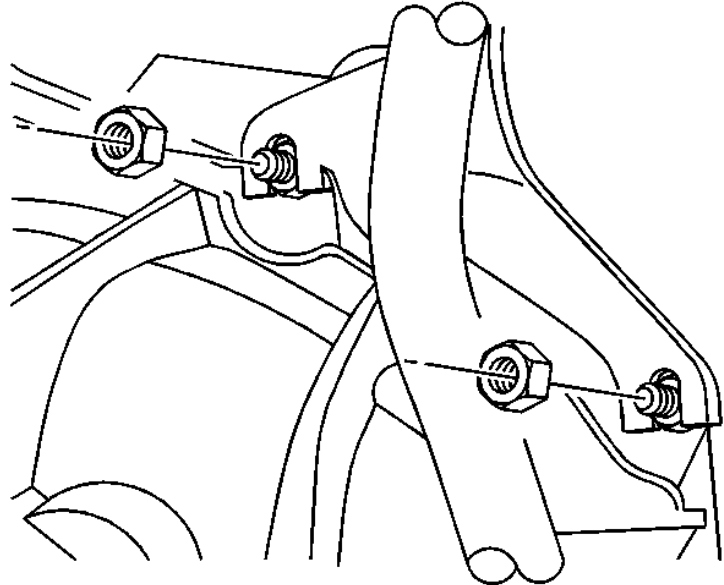

6. If using an OE/Stock turbocharger exhaust down pipe, remove the heat shield bolts and heat shield.

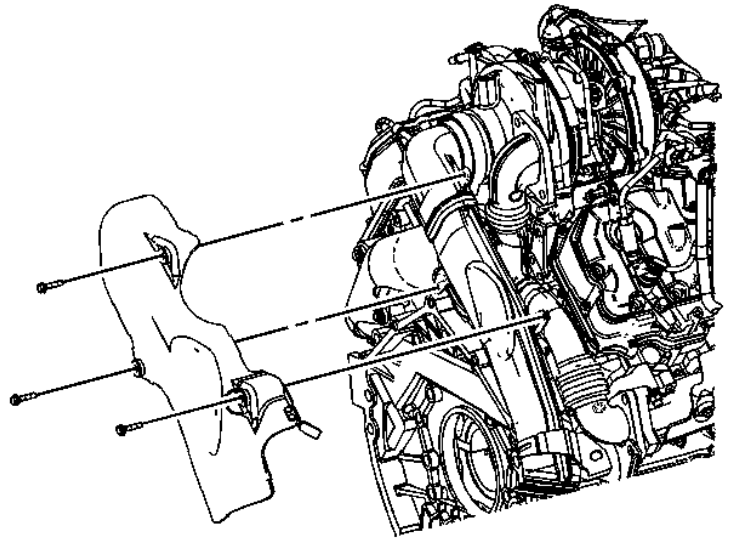

7. Using 12mm 12 point socket wrench remove the passenger side up pipe bolts.

Remove the up-pipe and discard the gaskets.

It is highly suggested to spray the bolts with a liquid thread loosener and let them soak.

Applying heat to the bolt is also a good method to loosen the bolt.

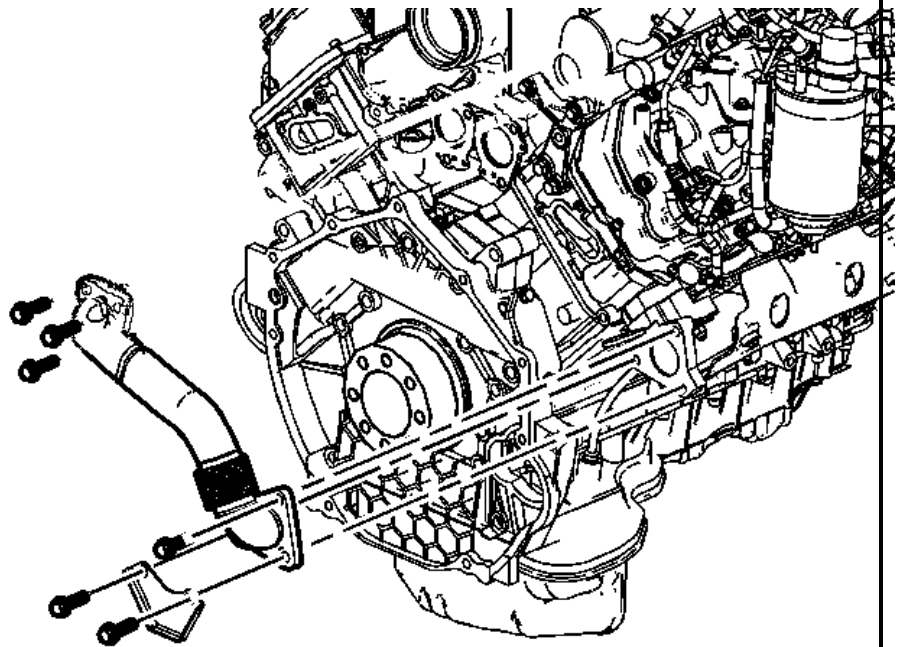

For race vehicles, now would be the time to install an EGR cooler delete.

8. Clean up feed port mating surface on the turbo and exhaust manifold with plastic scraper.

Position the passenger side BD-exhaust up-pipe (1403802) with the new BD gaskets 1403801-G2 (turbo side) and 1403801-G1 (Manifold side).

Loosely install the up-pipe to exhaust manifold and turbocharger.

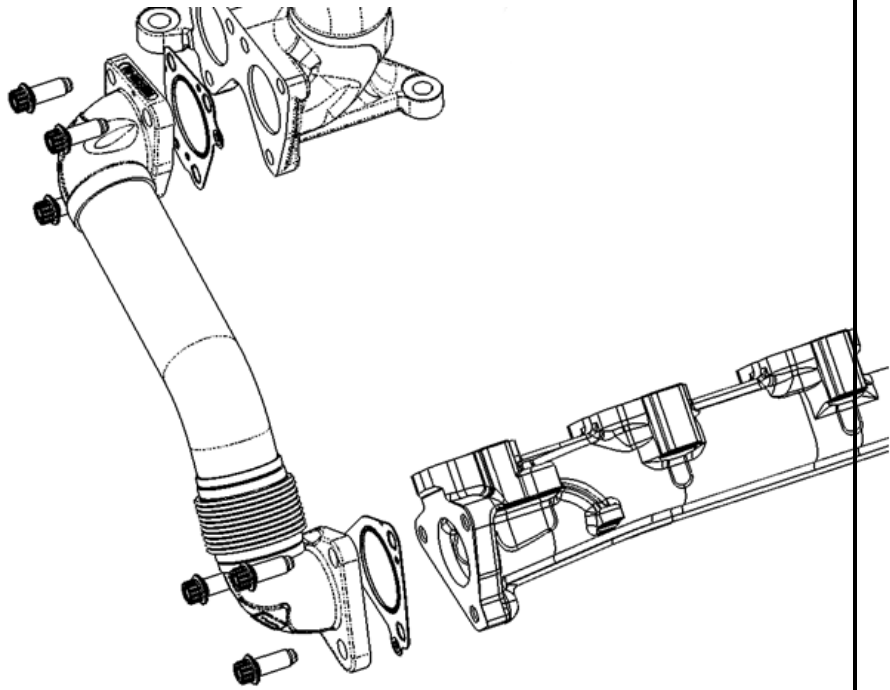

BD Engine Brake Inc.

Plant Address: 33541 MacLure Rd. Abbotsford, BC, Canada V2S 7W2

U.S. Shipping Address: 88-446 Harrison St, Sumas, WA 98295 U.S. Mailing Address: P.O. Box 231, Sumas, WA 98295

Phone: 604-853-6096 | Fax: 604-853-8749 | Internet: www.bd-power.com

9. You must check for clearances at this critical point. Move the up-pipe to maximize this clearance.

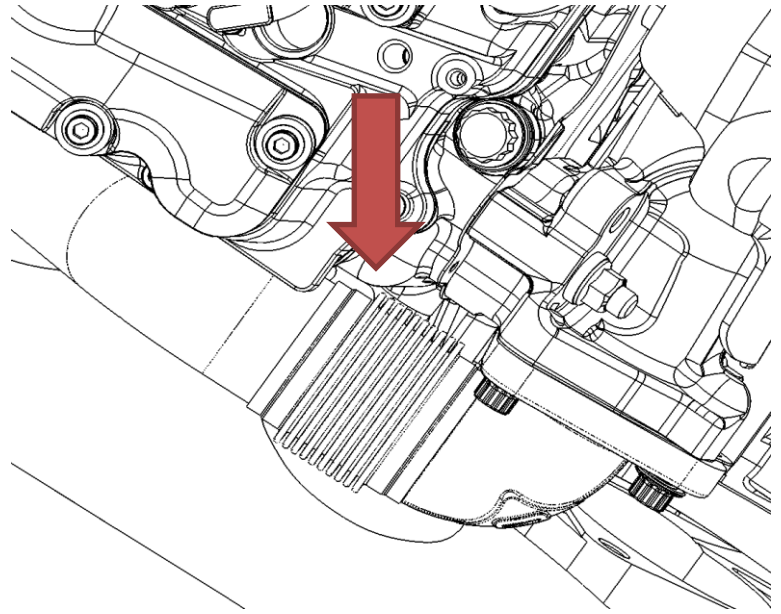

10. Tighten the exhaust up-pipe bolts in the sequence shown. Torque the bolts to 53 Nm (39 lbft)

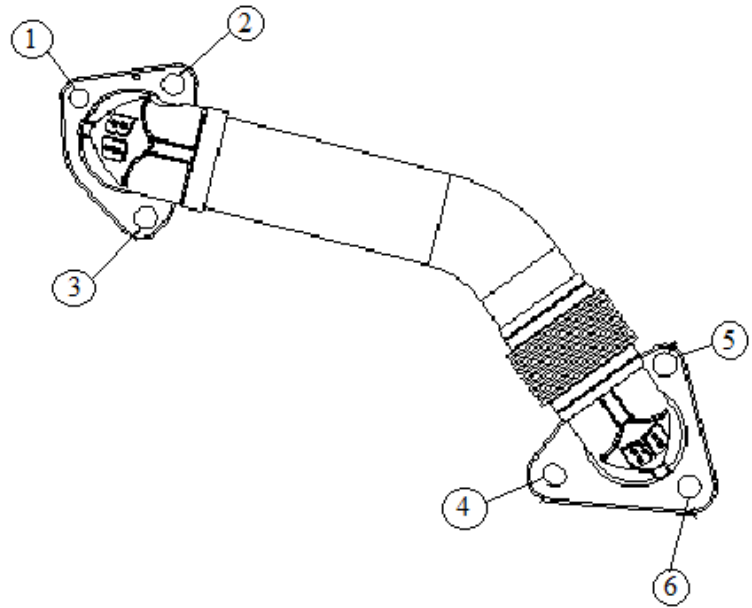

11. To install the driver side up-pipe remove driver side wheel and wheel well.



12. Remove the exhaust pipe heat shield bolts and heat shield and discard.

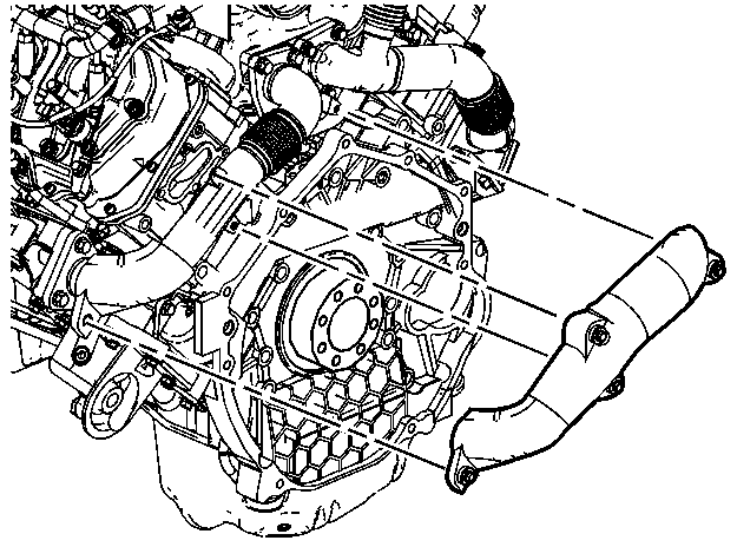

13. Using 12mm 12point socket wrench remove the driver side up pipe bolts.

Remove the driver side exhaust up-pipe bolts and the up-pipe. Discard the gaskets.

It is highly suggested to spray the bolts with a liquid thread loosener and let them soak.

Applying heat to the bolt is also a good method to loosen the bolt.

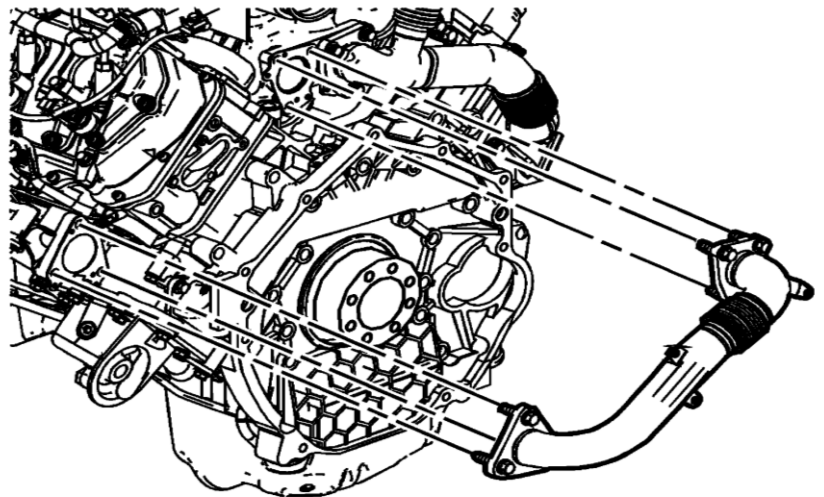

14. Using a plastic scrapper clean the feed port mating surface on the turbo and exhaust manifold.

Position the BD driver's side exhaust up-pipe (1403801) and the new BD-gasket 1403801-G2 on to the turbocharger.

Loosely install up-pipe using the three turbocharger bolts.

Insert gasket (1403801-G1) to exhaust manifold and loosely install the exhaust pipe to exhaust manifold.

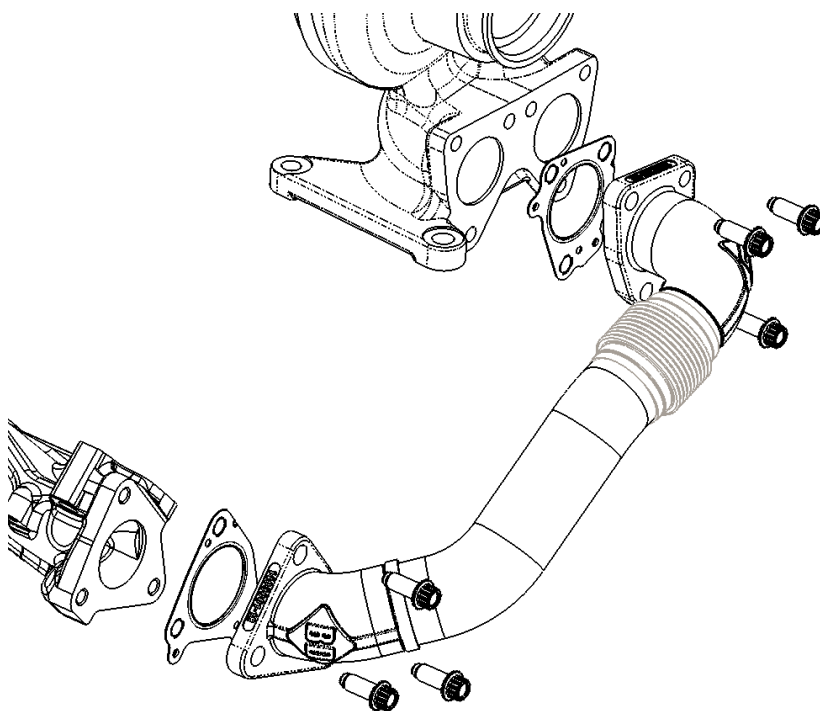

15. Check this area for clearance.

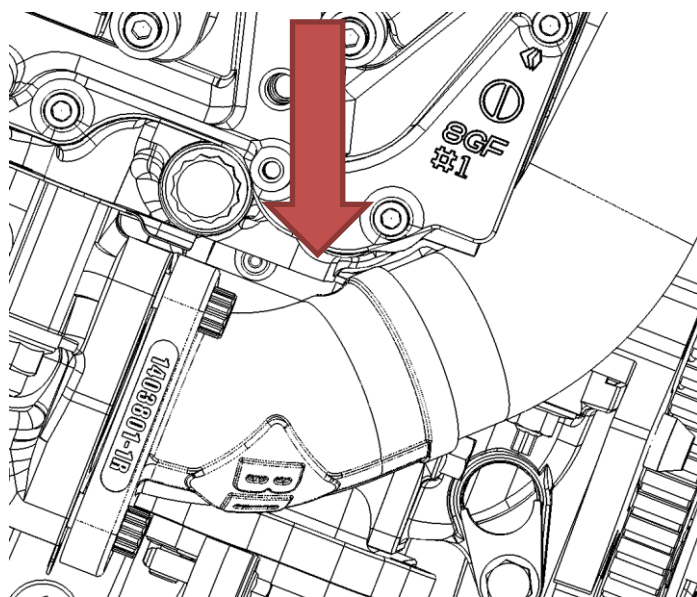

16. Tighten the BD-exhaust up pipe in the sequence shown. Torque the bolts to 53 Nm (39 lbft)

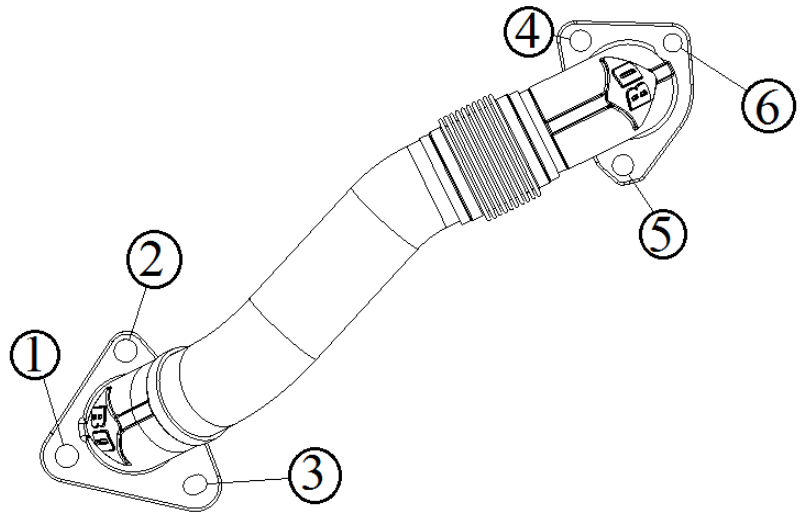

BD Engine Brake Inc.

Plant Address: 33541 MacLure Rd. Abbotsford, BC, Canada V2S 7W2

U.S. Shipping Address: 88-446 Harrison St, Sumas, WA 98295 U.S. Mailing Address: P.O. Box 231, Sumas, WA 98295

Phone: 604-853-6096 | Fax: 604-853-8749 | Internet: www.bd-power.com

Turbocharger Downpipe Installation

To maximize the performance of the uppipes we left them unaltered or compromised. As such there is a chance you will need to deform your aftermarket performance downpipe (Diamond Eye or MBRP).

17. First test fit the downpipe in the application. There will need to be at least 1/16" of clearance between the downpipe the up pipes. Ensure there is more clearance from the fire wall.
18. If clearance is unacceptable, mark the area of concern on the downpipe.
19. Remove downpipe, using a vice and ball peen hammer, massage/compress downpipe in critical areas.
20. Re-install and re-check. Repeat this process.

Note: You may need to remove heat wrap to perform the conforming operation. We have provided additional heat wrap.

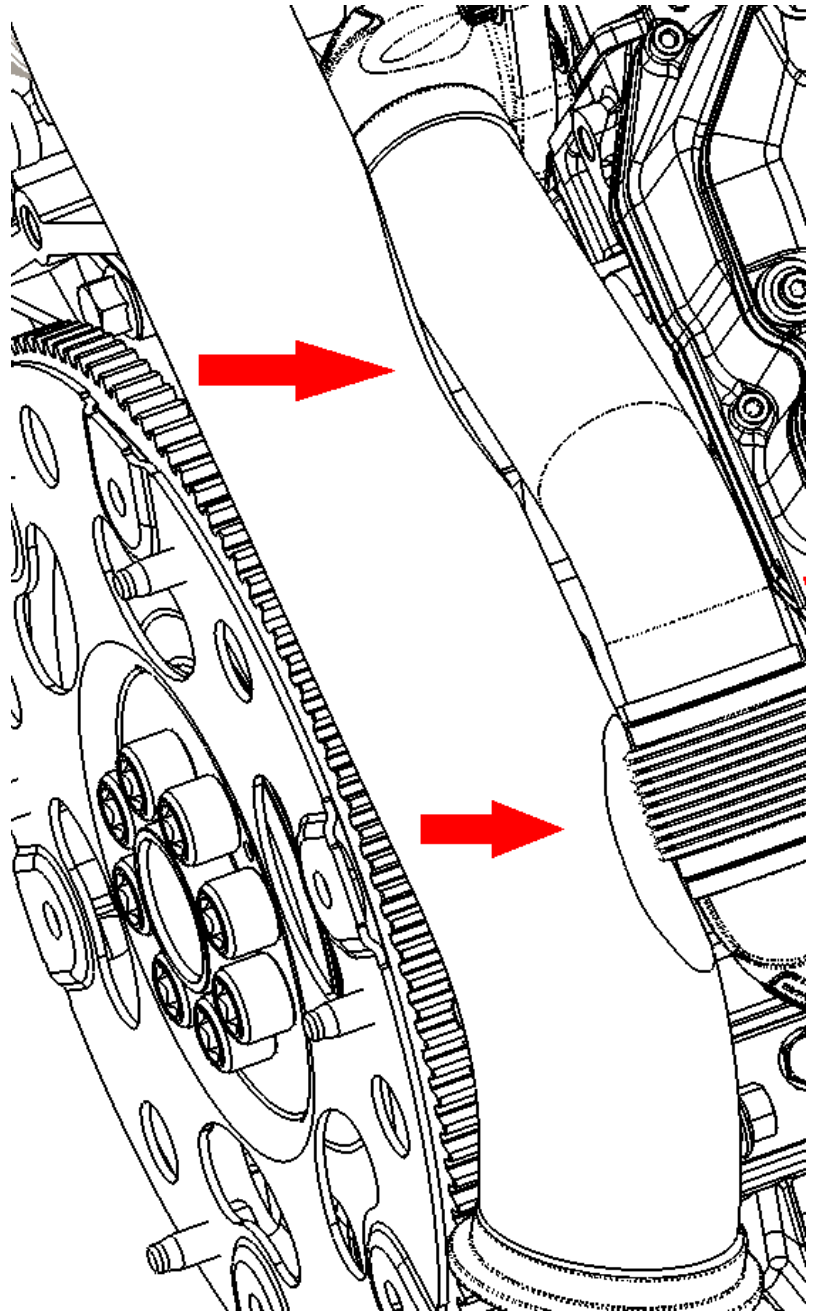

21. Once the clearances are sufficient, you can re-install the downpipe.

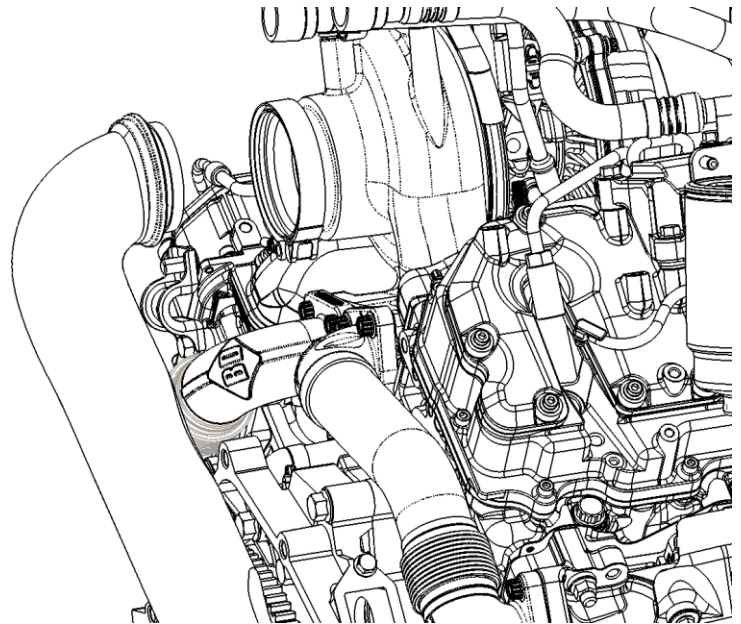
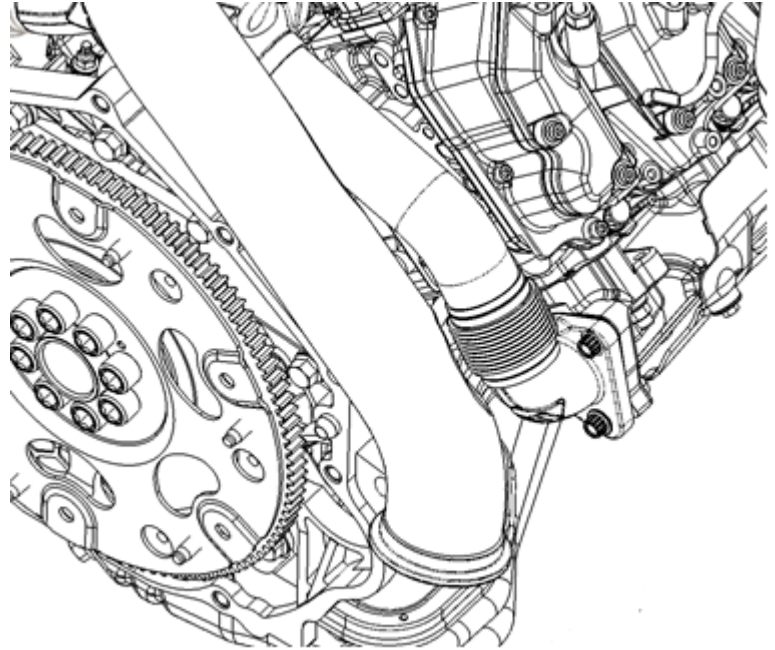

22. Tighten the turbocharger exhaust pipe to turbocharger V-clamp bolt.

FINGER TIGHT ONLY

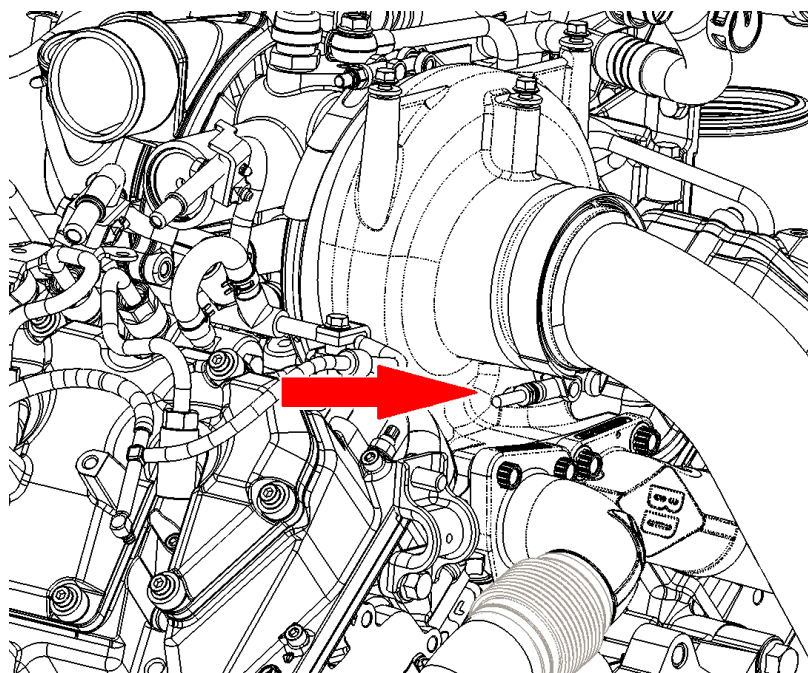

23. Re-install the transmission fluid fill tube. Install fluid fill tube to bellhousing nuts. Torque the nuts to 18 Nm (13 lbft).

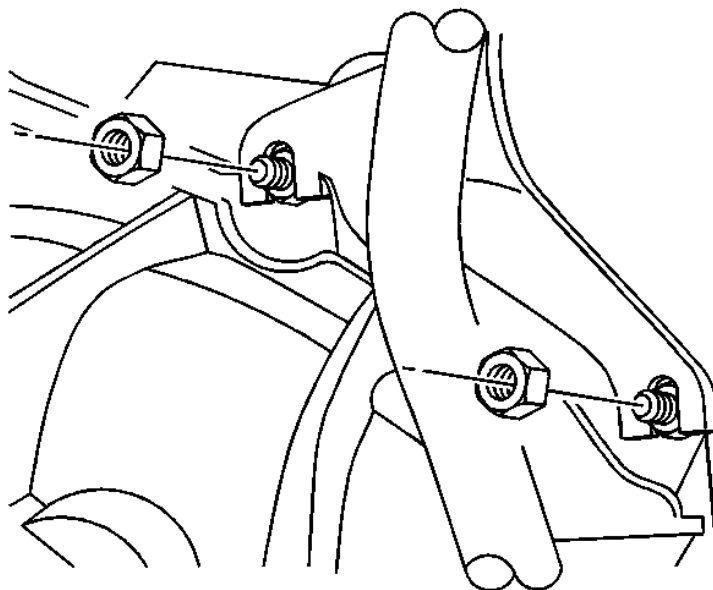

24. Connect downpipe to exhaust system with OE V Band clamp. Tighten to 34Nm (25 lbft).

Secure the upper downpipe clamp now. Torque the bolt to 15 Nm (11 lbft).

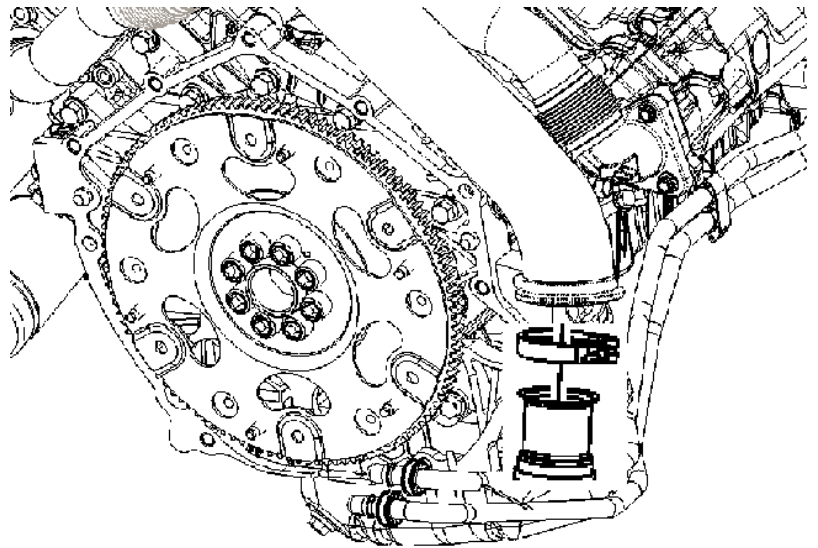

25. Re-install the turbocharger heat shield and glow plug controller if removed.

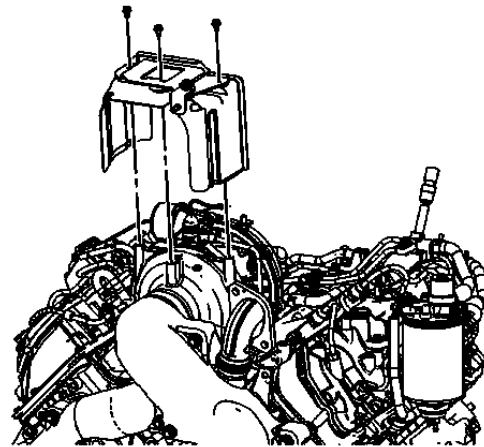

26. Re-Install transmission and all wheel well liners.
27. Start the engine and inspect for exhaust leaks.
28. Take vehicle for test drive and ensure no vibrations are heard.

If you have any technical difficulties, concerns, comments, or complaints, please phone our Technical Support hotline at (800) 887-5030 between 8:30am-5:00pm PST (Pacific Standard Time) Monday to Friday.