



INSTALLATION INSTRUCTIONS

MAKE: GM
MODEL: DURAMAX
YEAR: 2007.5-2010
ENGINE: V8-6.6L (td) LMM
WHEELBASE: 153"

4" Race Pipe
49-04014 (AL)
49-44019 (409 SS)
CCSB (Crew Cab Standard Bed)

THIS PART IS RACE USE ONLY

This is a "Race Only" product used solely for competition. It's use is limited to closed-course and open-course racing that is formally sanctioned by a recognized racing organization. Any other use, including recreational off-road use, could be in violation of local, state and/or federal laws. This system also requires an aftermarket electronic module to work properly with vehicle.

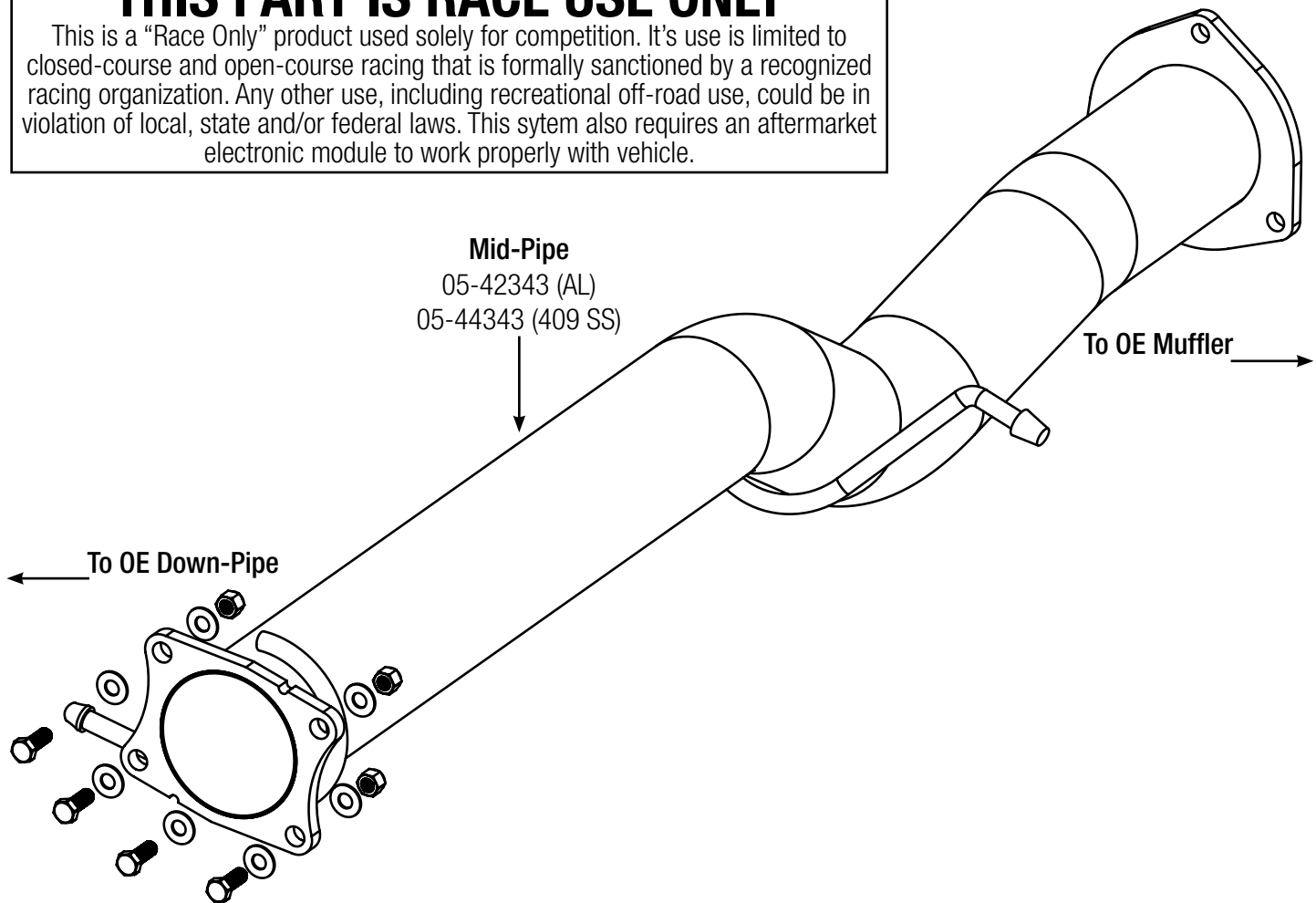

Step 1: (Read Instructions prior to installation) Disconnect sensors at the connections. Take caution as not to damage any sensors. Remove CAT/DPF section of your trucks exhaust working your way forward. Take caution not to damage the factory isolation mounts as they will be reused. **It is recommended to not fully tighten the clamps until the entire system has been installed.**

Step 2: For faster installation spread the pieces of the exhaust along side of your vehicle according to the diagram shown.

Step 3: Install mid-pipe using provided hardware.

Step 4: Re-install OE sensor and connect to harness on 49-44019 "only".

Step 5: Adjust for alignment and tighten all connections. Your installation is now complete. It is recommended to re-tighten all exhaust components after the first 50-100 miles.

NOTES:

- aFe recommends that the tailpipe be at least 1/2"-1" away from any body panels to avoid heat related body damage. **Tighten and secure.**
- Controller/Programmers are required to operate this system.

Caution: Allow time for your vehicle to cool down prior to installation. When working on or under your vehicle proceed with caution. Exhaust systems reach high temperatures and may cause serious burns. Wear protective safety equipment; eye goggles and gloves to ensure a safe installation. **aFe recommends professional installation on our products.**