



**Installation Manual v1.0:
P/N 301-900-3368
6R140 Deep Transmission Pan
2011-2014 Ford Power Stroke with 6.7L**

Please read all instructions before installation.

Tools Needed for Installation:

- 10qt or larger oil drain pan
- 3/8" Allen Wrench
- 5mm Allen Wrench (preferably a socket)
- 8mm Socket
- 13mm Socket or Wrench
- Funnel that fits into dipstick tube
- Wheel chocks

Additional Items:

- 16-18 Quarts of Transmission Fluid (see below for specifics)
- Transmission Filter (if replacing)
- Transmission Pan Gasket (if damaged or leaking)



A complete list of parts can be found on the last page of the instruction manual. Please Check that all parts are present before installation.

1. Park the vehicle on level ground and place the transmission in PARK. If a lift or hoist is available it makes installation easier, however, installation can be done in a driveway. Place wheel chocks or a similar device under tires to ensure vehicle cannot roll during installation. Place the vehicle in NEUTRAL.
2. Locate an oil drain pan capable of holding over 10 quarts of fluid and is large enough to catch dripping oil when the pan is removed. Place the pan under the transmission drain plug.
3. Remove the transmission fluid pan drain plug and allow the transmission fluid to drain until oil drips every 3-4 seconds.
4. Reinstall the factory drain plug.
5. Remove the 19 bolts holding the factory transmission pan in place, remove the pan and gasket.

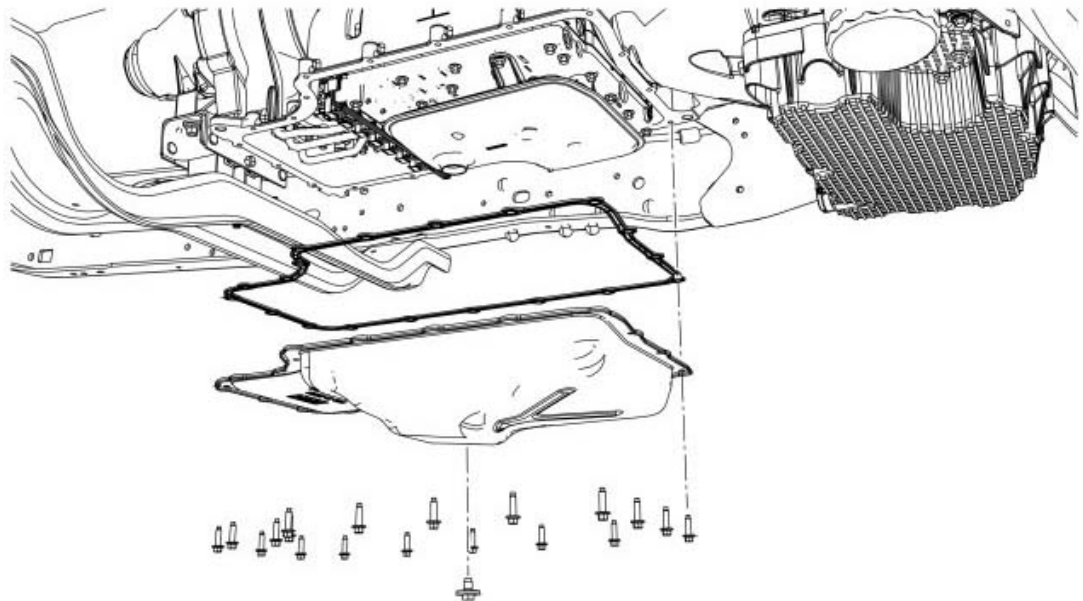

NOTE: Clean and check the transmission pan gasket. The factory transmission pan gasket is reusable. Do not discard it unless there is damage to the gasket or it is leaking.

6. Check the factory magnet for any signs of debris in the transmission as this can be an early warning sign for future transmission issues.
7. If changing the transmission fluid filter, remove the 3 bolts holding it in place. If not changing the filter, skip to step 9.

NOTE: The Power Stroke owner's guide says to change the transmission fluid and filter every 150,000 miles. This is due to the criteria used by Consumer's Reports to rate cost of maintenance. We strongly suggest performing full transmission services every 30,000 miles, particularly if the truck is used primarily for towing.

- Lubricate the o-ring seal on the new filter with clean transmission fluid. Install the filter and torque the 3 bolts to **11Nm (97 lb-in)**.



- Install the ATS Billet Extended Pickup Tube Assembly as shown.



At an angle, slide the pickup tube assembly into the filter pickup with the machined flats even.



Rotate into the filter until parallel.



From below, rotate the outer piece clockwise while holding the inner piece still until hand tight.

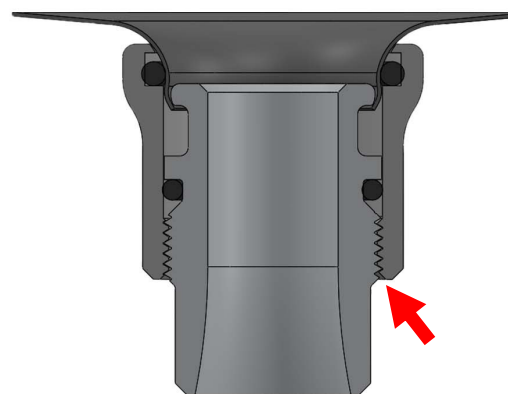

When completely installed, the beginning of the threads on the inner piece will become visible and the pickup tube should be rigidly held into the filter.

10. Install the new ATS Deep Transmission Pan using the new hardware provided. Torque the bolts to **9 Nm (80 lb-in)** in a crisscross pattern.
11. The ATS Deep Transmission Pan adds 8 quarts of capacity to the transmission. A typical service requires the addition of 8.2 quarts and if valvebody work was done at the same time, the transmission would require the addition of 10.2 quarts. This means with the deep transmission pan, the transmission will require adding **16-18 quarts** of fluid to fill properly.

NOTE: Ford suggests using Motorcraft®
 MERCON® LV Automatic
 Transmission Fluid P/N XT-10-QLVC



12. Remove the dipstick and place the funnel in the dipstick tube. Start adding fluid. Add 14-16 quarts to start with. This should not completely fill the transmission but the extended pickup tube will be immersed in fluid.
13. Start the engine. Move the selector lever through all gear ranges while checking for engagements to allow the main control hydraulic circuits to fill with transmission fluid.
14. With the engine running get the transmission up to operating temperature (180-200°F). This may take some time as we typically see a 10°F drop in average fluid temperature with the deep pan installed. Check the transmission fluid level and add fluid in increments of 1/4-1/2 quart until the proper level is achieved.

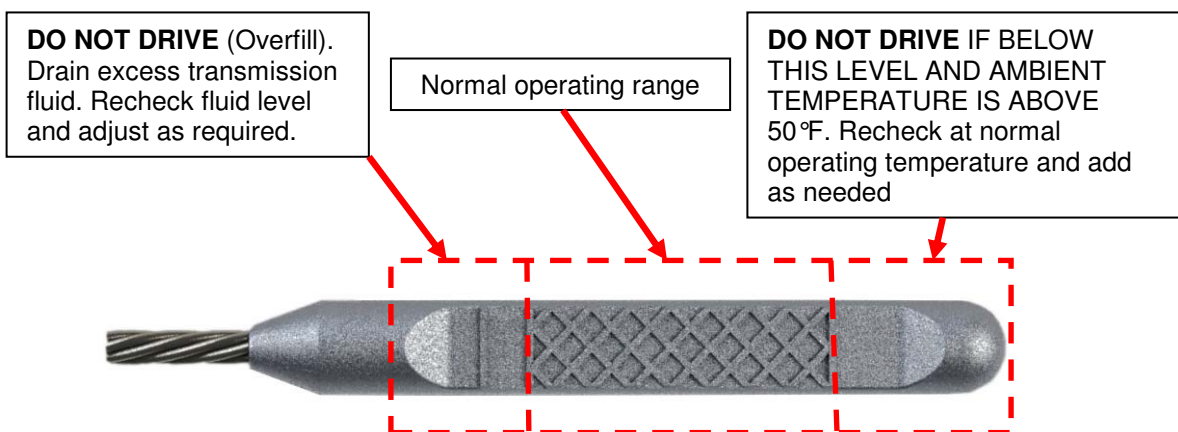

15. After warming up the transmission and adding fluid, re-torque the transmission pan bolts.
16. Check for leaks. If none are present, the vehicle is ready to drive.

Have Any Questions?

Thank you for purchasing the ATS 6R140 Deep Transmission Pan. Please check our website at <http://www.atsdiesel.com> for technical support and other products such as the 5-Star™ torque converter, ATS High Performance Valve Body and ATS High Performance Transmission. Please call or e-mail our Technical Service Department, 8:00am to 5:30pm Mountain Standard Time, Monday through Friday.

Contact Information

Toll Free: 800-949-6002

Local: 303-431-7973

Fax: 303-431-0135

Website: www.ATSDiesel.com

Email: info@ATSDiesel.com

We strive to make our instructions as clear and complete as possible. To achieve this, our instructions are under constant construction. We encourage you to visit our website to check for the most up-to-date manuals and diagrams as well as other information. If you have any suggestions as to how we can improve this installation manual, let us know at <mailto:Suggestions@ATSDiesel.com>.

Bill of Materials

1. ATS 6R-140 Deep Transmission Pan.....301-100-3326
2. ATS Magnetic Drain Plug (installed in pan).....402-009-1000
3. ATS Billet Extended Pickup Tube Assembly.....301-019-3368
4. (19) M6-1.0x25mm Stainless Steel Socket Head Cap Screws
5. (19) M6 Washers