

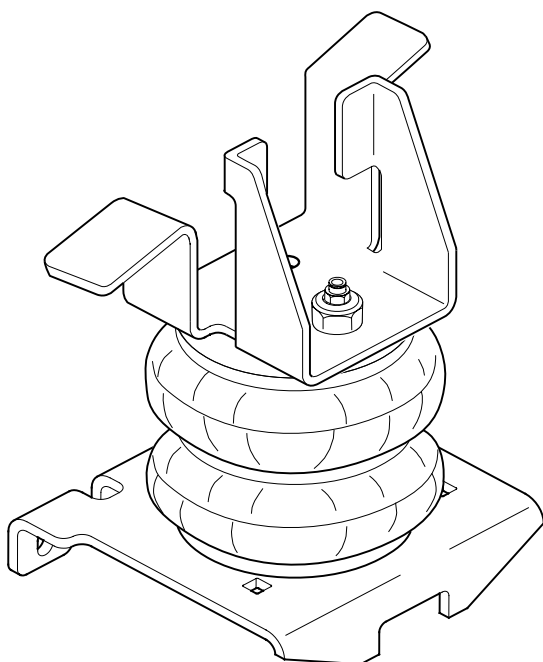

riderite.com

INSTALLATION INSTRUCTIONS



SECTION 1 - AIR SPRING

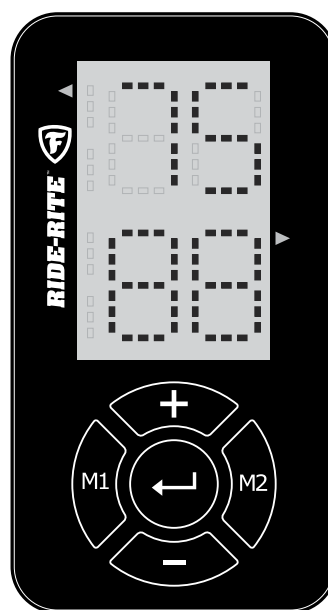

SECTION 2 - AIR ACCESSORY

Firestone

*World's Number 1
Air Spring.*



FIRESTONE INDUSTRIAL PRODUCTS COMPANY

! IMPORTANT

PLEASE DON'T HURT YOURSELF, YOUR KIT OR YOUR VEHICLE. TAKE A MINUTE TO READ THIS IMPORTANT INFORMATION.

This kit is to be used on a **pickup truck only**, and **DOES NOT INCREASE YOUR VEHICLE'S MAXIMUM LOAD**.

SAFE INSTALLATION

Please take all safety precautions during installation. A hydraulic jack can fail, and if that happens, you can be seriously hurt, or worse, if you are relying on it to hold up the vehicle. If you use a hydraulic jack, secure jack stands in the appropriate locations and chock any tires still touching the ground.

Wear safety glasses or goggles. Your eyes may be lower than some parts and pieces, and you don't want to lose an eye.

Remove the possibility of any electrical issues by disconnecting the negative battery cable.

KIT CLEARANCE

There must be a minimum of 1/2" clearance around all installed components when the Air Springs are inflated and under a load. The Air Springs must flex and expand during operation, so the clearance keeps the kit from rubbing against parts of the vehicle.

VEHICLE GVWR

NEVER exceed the maximum load recommended by the vehicle manufacturer (GVWR). The GVWR can be found in your vehicle's owner's manual or on the data plate on the driver's side door. Consult your local dealership for additional GVWR specifications.

INFLATING THE AIR SPRINGS

When inflating Air Springs, add air pressure in small quantities, checking air pressure frequently. The Air Springs have much less air volume than a tire, so they inflate much more quickly.

PRESSURE TO LOAD

The Air Springs will support approximately 50 lbs. of load for each PSI of inflation pressure (per pair). For example, 50 PSI of inflation pressure will support a load of 2500 lbs. per pair of Air Springs.

APPROPRIATE AIR PRESSURE

For best ride, use only enough air pressure in the Air Springs to level the vehicle when viewed from the side (front to rear). This will vary, depending on the load, location of the load, condition of the existing suspension, and personal preference.

OPTIONAL T-FITTING

This kit includes Inflation Valves and Air Line Tube for each Air Spring, allowing you to compensate for unbalanced loads. If you prefer a single Inflation Valve system to provide equal pressure to both Air Springs, your dealer can supply the optional "T" fitting (Part # 3025 or WRI-760-3461 retail pack).

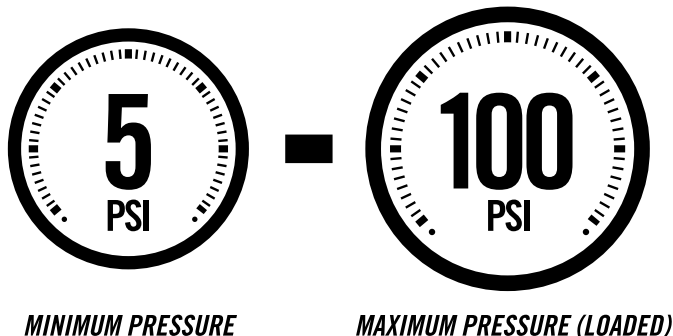

ONCE INSTALLED SUCCESSFULLY, FOLLOW THESE PRESSURE REQUIREMENTS FOR THE AIR SPRINGS:



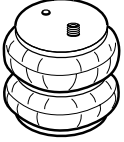
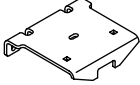
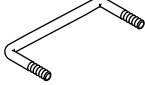
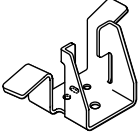
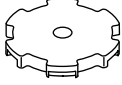
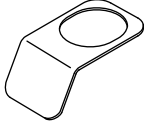
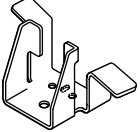
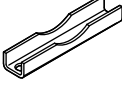

SECTION 1 PARTS

Compare the parts below to your kit. Assure you have all pieces, and organize them for an easier installation.









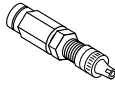

AIR SPRING CONTENTS

PART # 6401	 x2 AIR SPRING	PART # 5720	 x2 LOWER BRACKET	PART # 3429	 x2 BAIL CLAMP
PART # 5179	 x1 LEFT SIDE UPPER BRACKET	PART # 5721	 x2 JOUNCE BUMPER CUP INSERT	PART # 1004	 x1 HEAT SHIELD
PART # 5178	 x1 RIGHT SIDE UPPER BRACKET	PART # 5433	 x2 AXLE STRAP BRACKET	PART # 9416	 x1 AIR LINE TUBE (30 FEET)

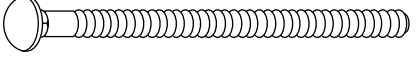
A24-760-7560 INFLATION VALVE BRACKET KIT

PART # 9483	 x1 NO-DRILL INFLATION VALVE BRACKET	PART # 9488	 x2 LARGE NYLON TIE
-------------	--	-------------	--

AIR SPRING HARDWARE PACK

PART # 3430	 x2 3/8" - 16 x 2" FLAT HEAD BOLT	PART # 3064	 x2 3/4" INTERNAL TOOTH LOCK WASHER	PART # 3032	 x2 INFLATION VALVE AND VALVE CAP ASSEMBLY
PART # 3142	 x2 3/8" - 16 x 5/8" FLAT HEAD BOLT	PART # 3033	 x4 5/16" FLAT WASHER	PART # 3015	 x4 3/8" - 16 x 7" CARRIAGE BOLT
PART # 3295	 x2 3/4" - 16 HEX NUT	PART # 3046	 x2 AIR FITTING	PART # 0899	 x2 THERMAL SLEEVE
PART # 3067	 x8 3/8" - 16 FLANGE NUT			PART # 9036	 x15 NYLON TIE

CONTENTS AND OVERVIEW

SECTION 1

PAGE 4 INSTALL JOUNCE BUMPER CUP

PAGE 5 UPPER & LOWER BRACKET INSTALLATION

PAGE 6 AIR SPRING ALIGNMENT & INSTALLATION

PAGE 7 FASTEN BAIL CLAMP

PAGE 8 FASTEN CARRIAGE BOLTS

PAGE 9 HEAT SHIELD & PASSENGER SIDE

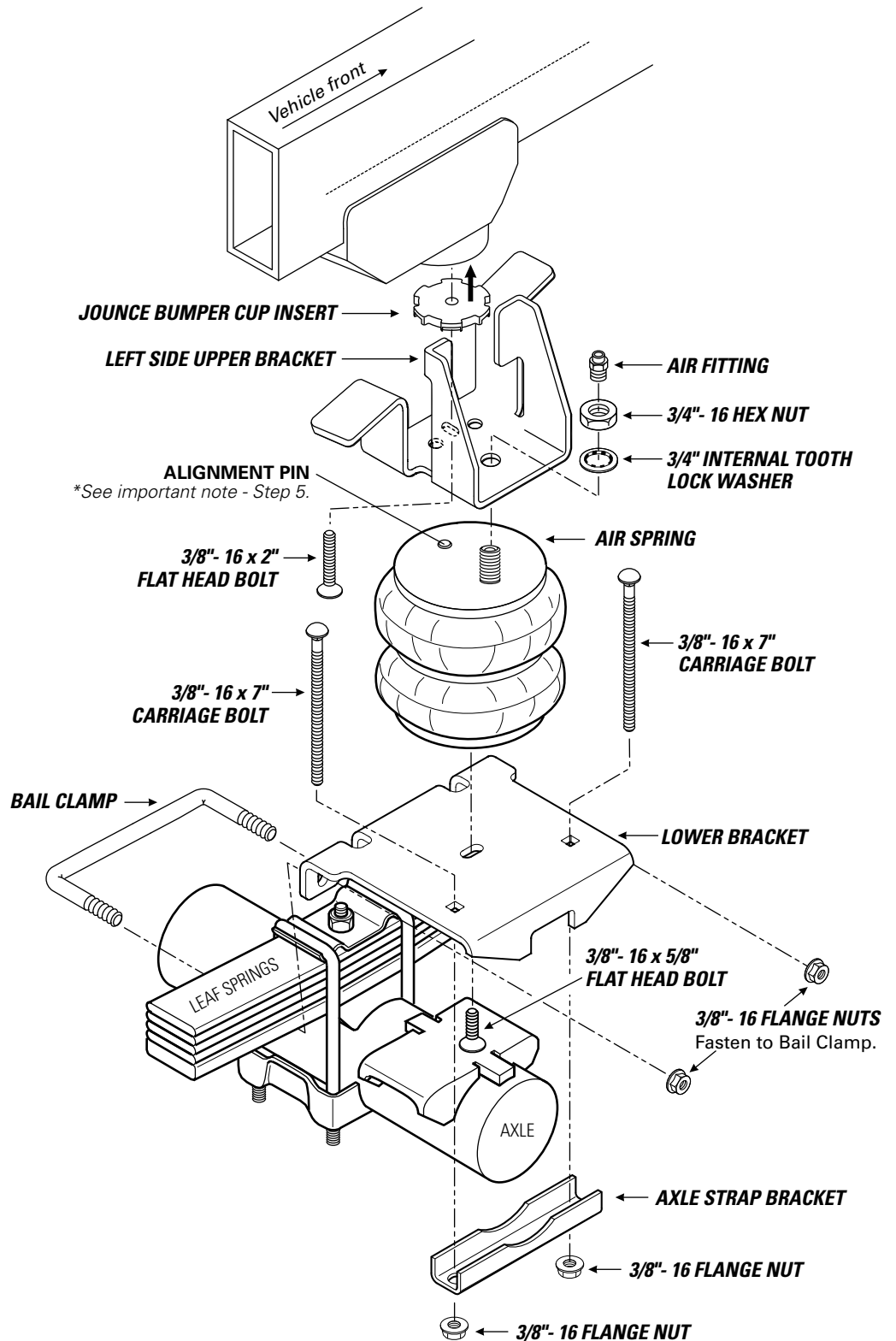

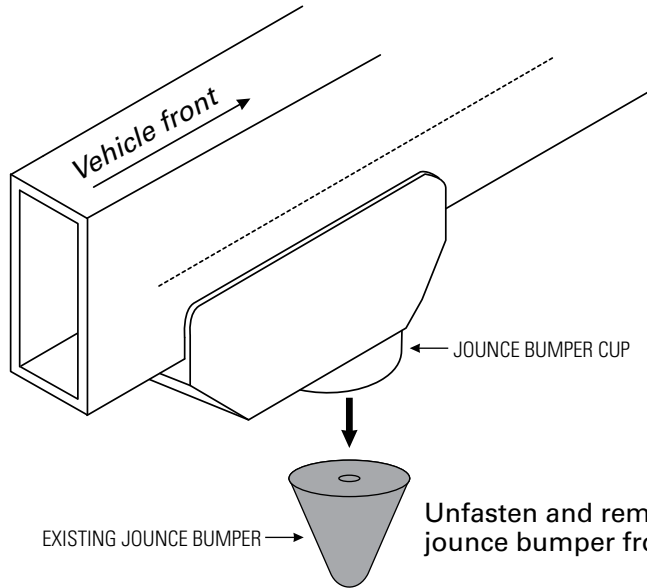

START THE INSTALLATION ON THE LEFT SIDE OF THE VEHICLE WHEN FACING FORWARD.

Unfasten and remove existing jounce bumper from the vehicle.

NOTE: The metal bumper cup stays on the truck!

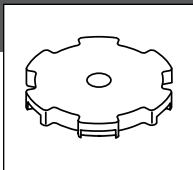

JOUNCE BUMPER CUP INSERT MUST REMAIN SEATED AT ALL TIMES DURING THE INSTALLATION. **IF NOT, IT CAN FALL OUT DURING OPERATION!**

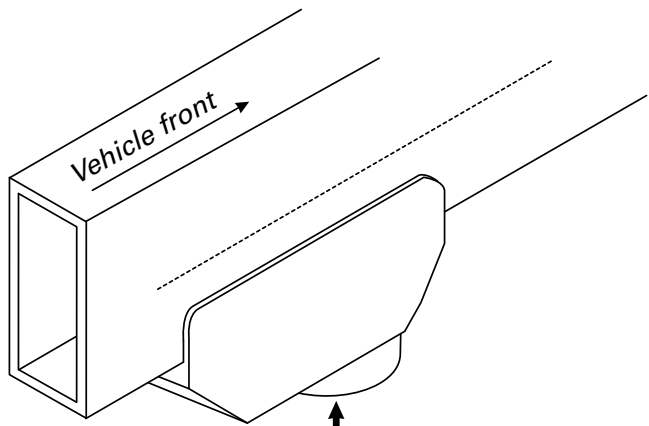

Install and seat Jounce Bumper Cup Insert.

Notches on Jounce Bumper Cup Insert face downward.

VIEW FROM BOTTOM

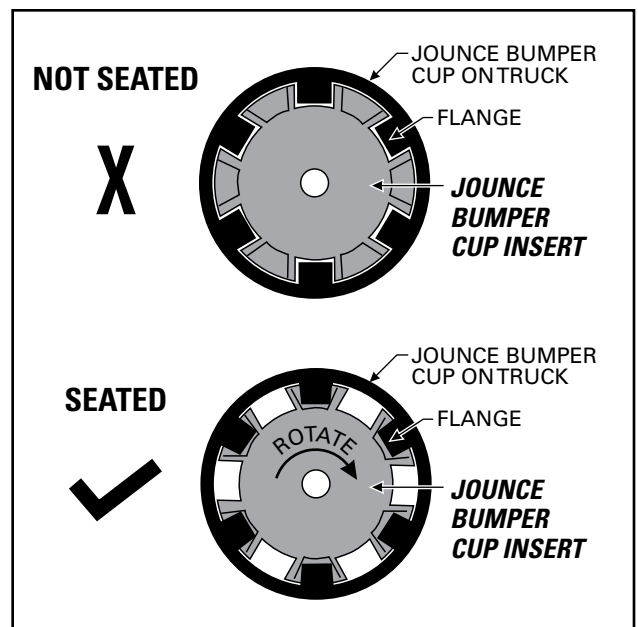

3

FASTEN UPPER BRACKET TO JOUNCE BUMPER CUP INSERT

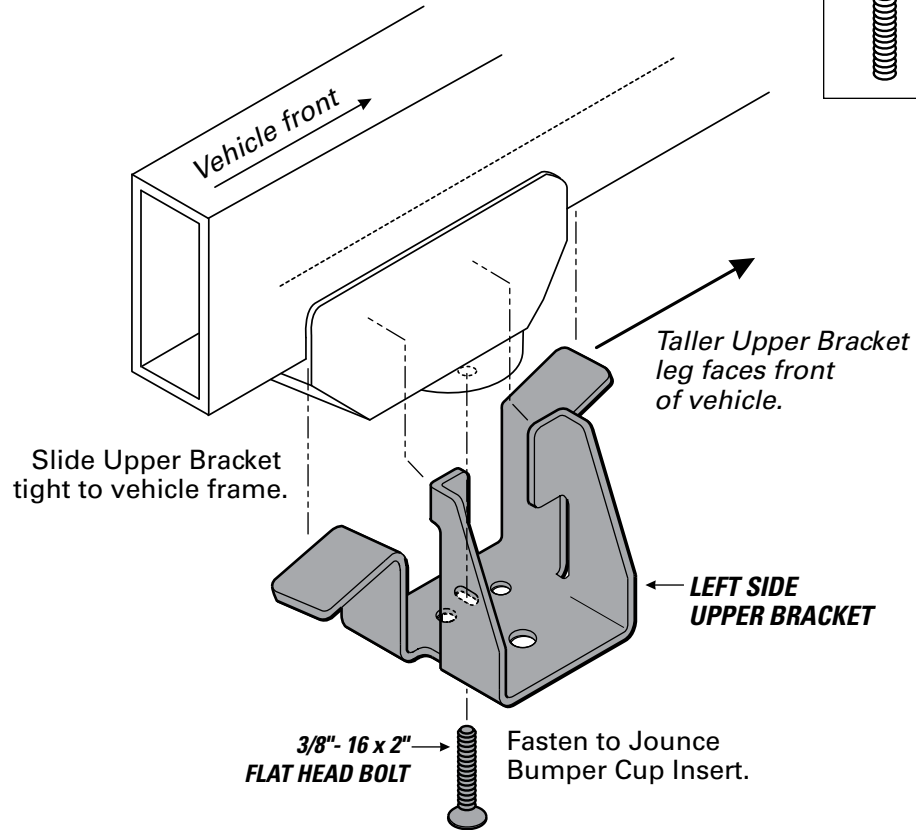
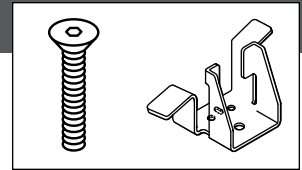

4

INSTALL AIR SPRING TO LOWER BRACKET

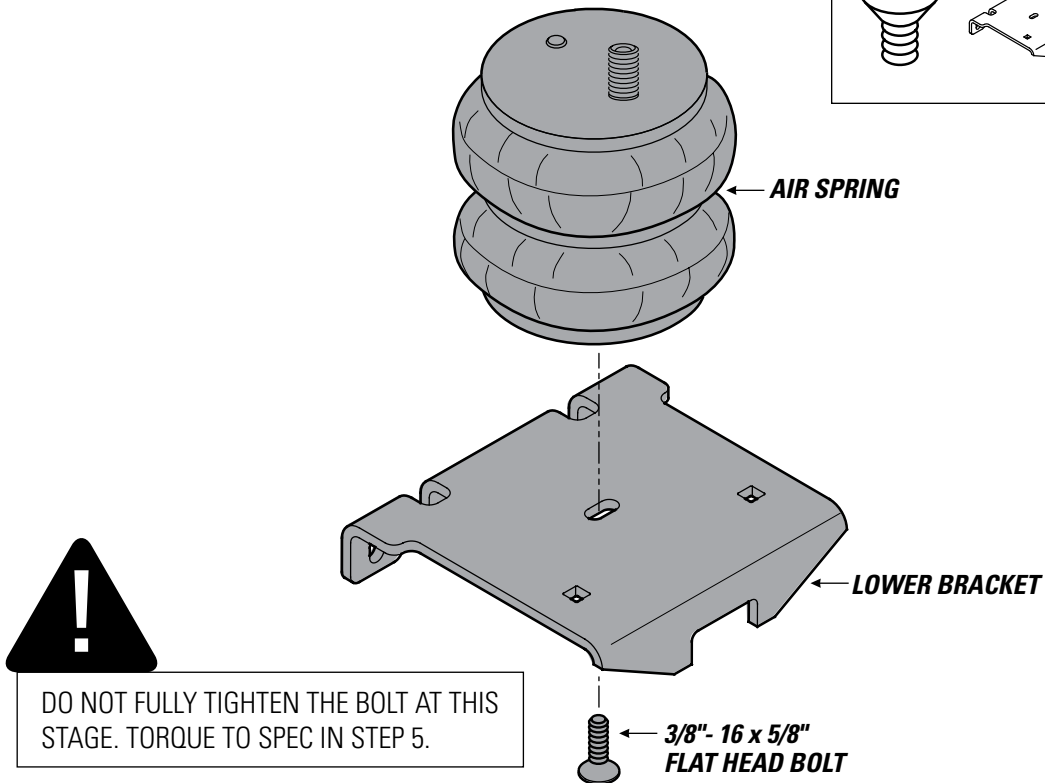
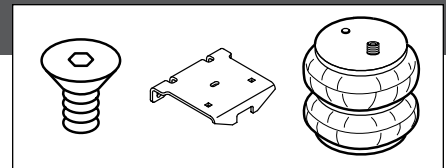

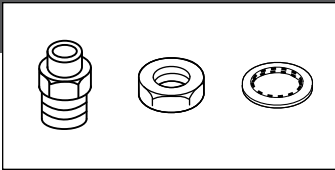

INSTALLING THE RIGHT SIDE? REMEMBER STEP 9 FIRST!

- 1** Follow guidelines below to dry fit assembly. Make alignment marks as shown.
- 2** Remove assembly and match alignment marks you made.
- 3** Tighten 3/8"-16 x 5/8" Flat Head bolt to 15-20 ft lbs.
- 4** Install assembly and follow the guidelines.

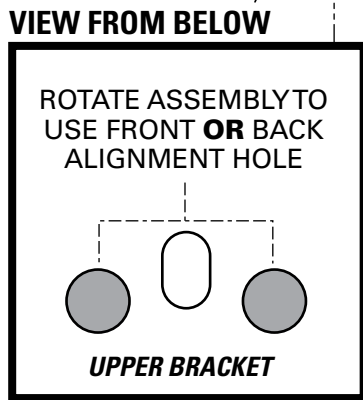
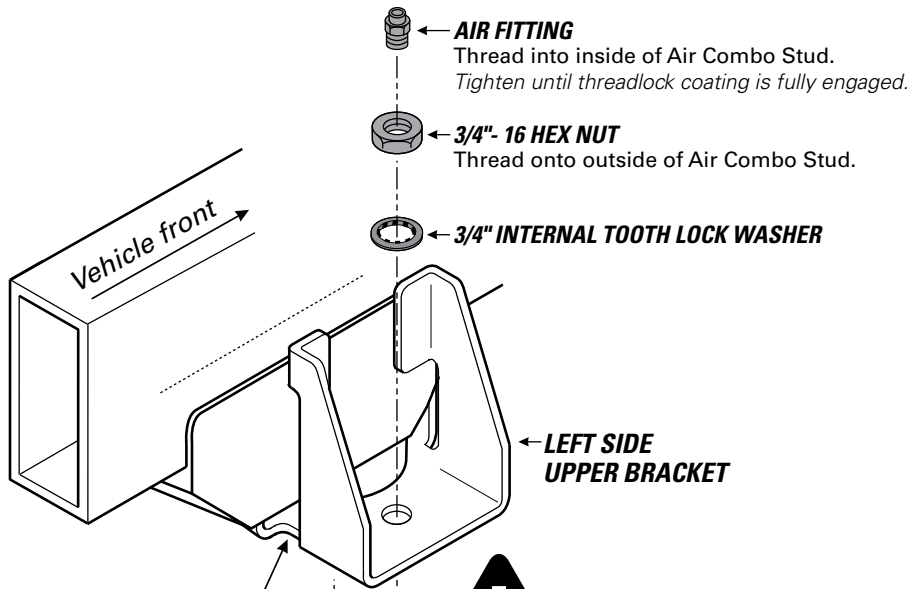

ALIGNMENT PIN ON AIR SPRINGS MUST BE INSTALLED TO FULLY SEAT INTO ONE OF THE ALIGNMENT HOLES IN THE UPPER BRACKET. FAILURE TO DO SO WILL CAUSE IT TO BE PUSHED INTO THE BEAD PLATE, CREATING AN AIR LEAK, AND RESULTING IN AN AIR SPRING FAILURE THAT IS **NOT WARRANTABLE. THE ALIGNMENT PIN CANNOT HOLD 2,500 LBS! IT IS USED FOR ALIGNMENT ONLY!**

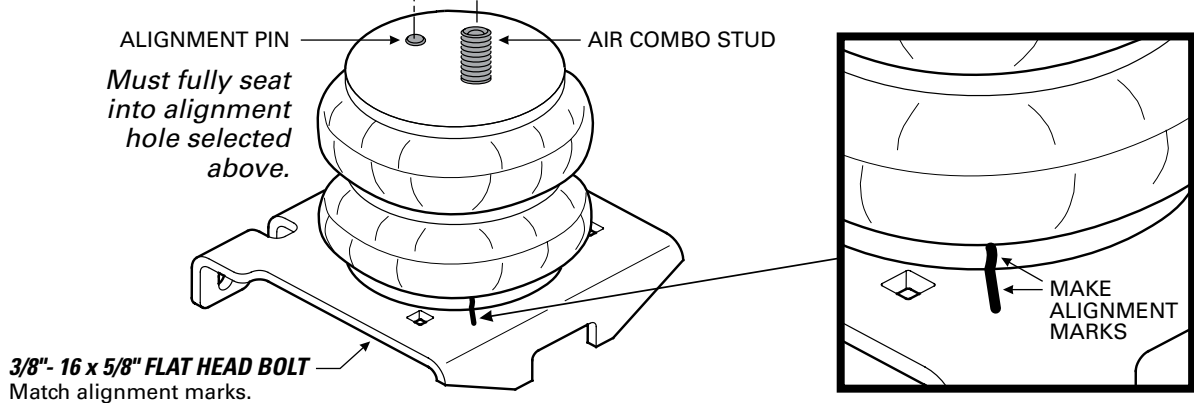

6

SECURE LOWER BRACKET BAIL CLAMP

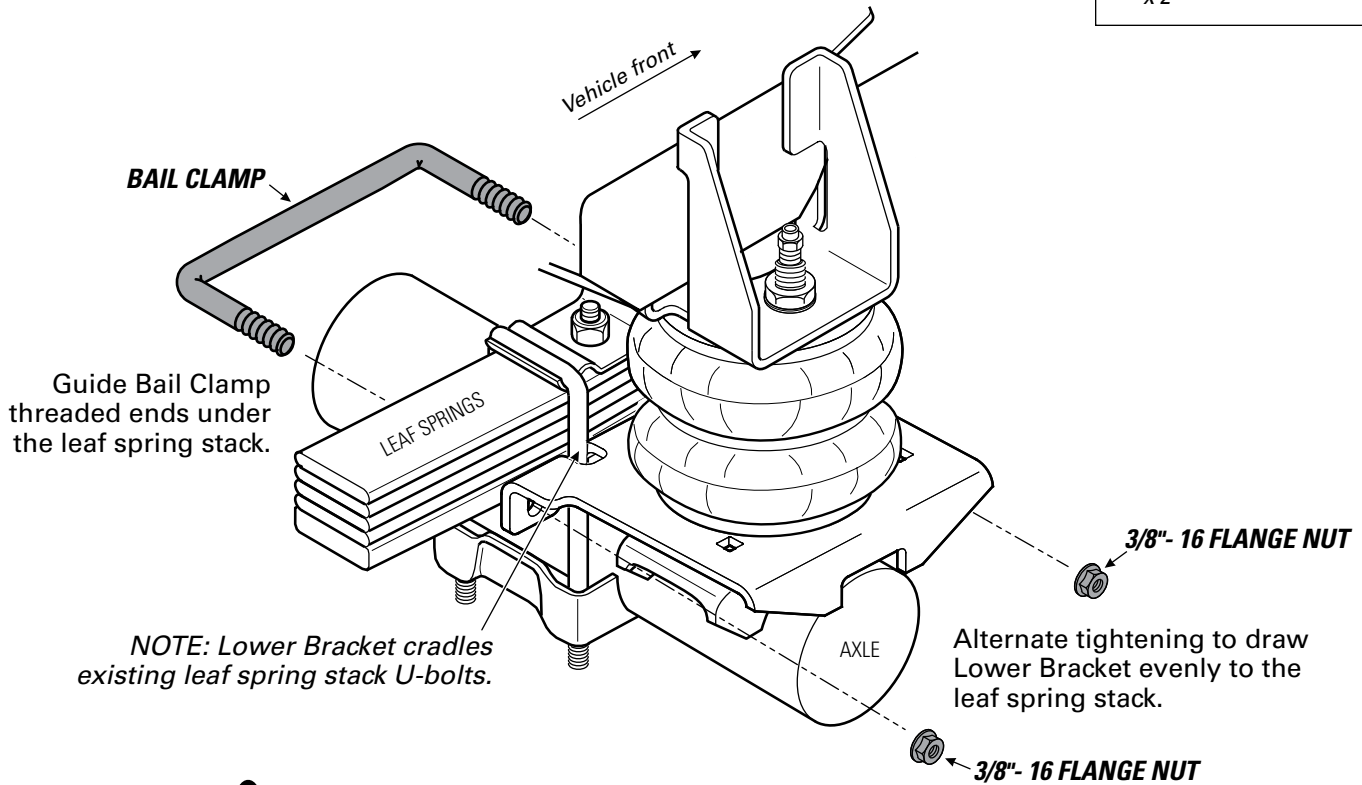
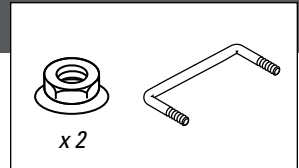

USE YOUR HAND TO CHECK FOR THE PROPER CLEARANCE AROUND THE AIR SPRING. IF YOUR HAND DOES NOT FIT BETWEEN THE AIR SPRING AND OTHER COMPONENTS, IT WILL RUB!



FROM THIS VIEW, THE AIR SPRING SHOULD BE STRAIGHT FROM SIDE TO SIDE.

LEFT SIDE VIEW FROM REAR

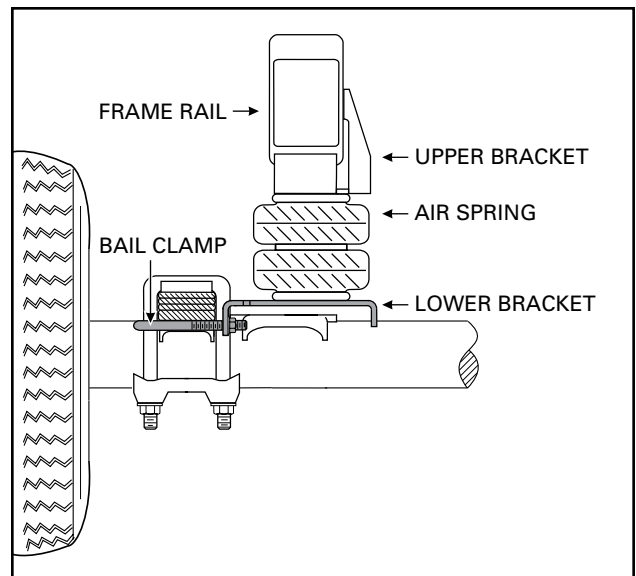

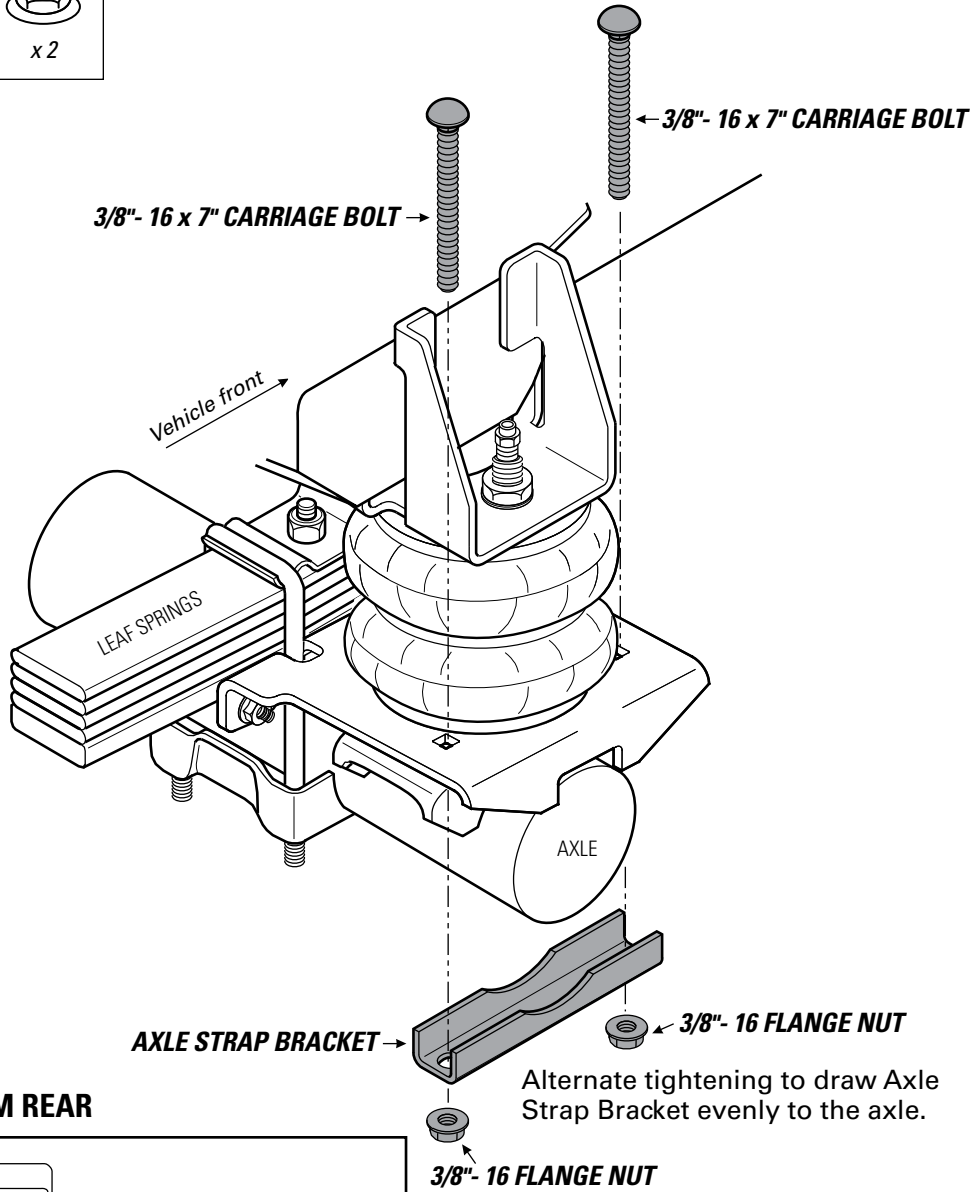
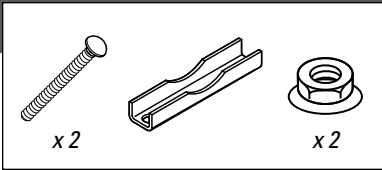

LEFT SIDE VIEW FROM REAR

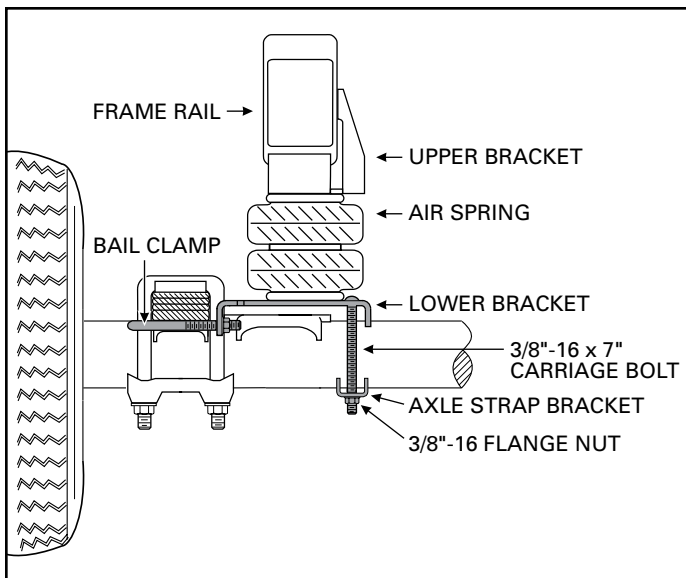

FROM THIS VIEW, THE AIR SPRING SHOULD BE STRAIGHT FROM SIDE TO SIDE.



AWESOME! You're done with the left side. The right side installation is the same, with the addition of this step. Go complete Steps 2-4 for the right side, then complete this step before continuing to Step 5.



RIGHT SIDE INSTALLATION MUST INCLUDE HEAT SHIELD!

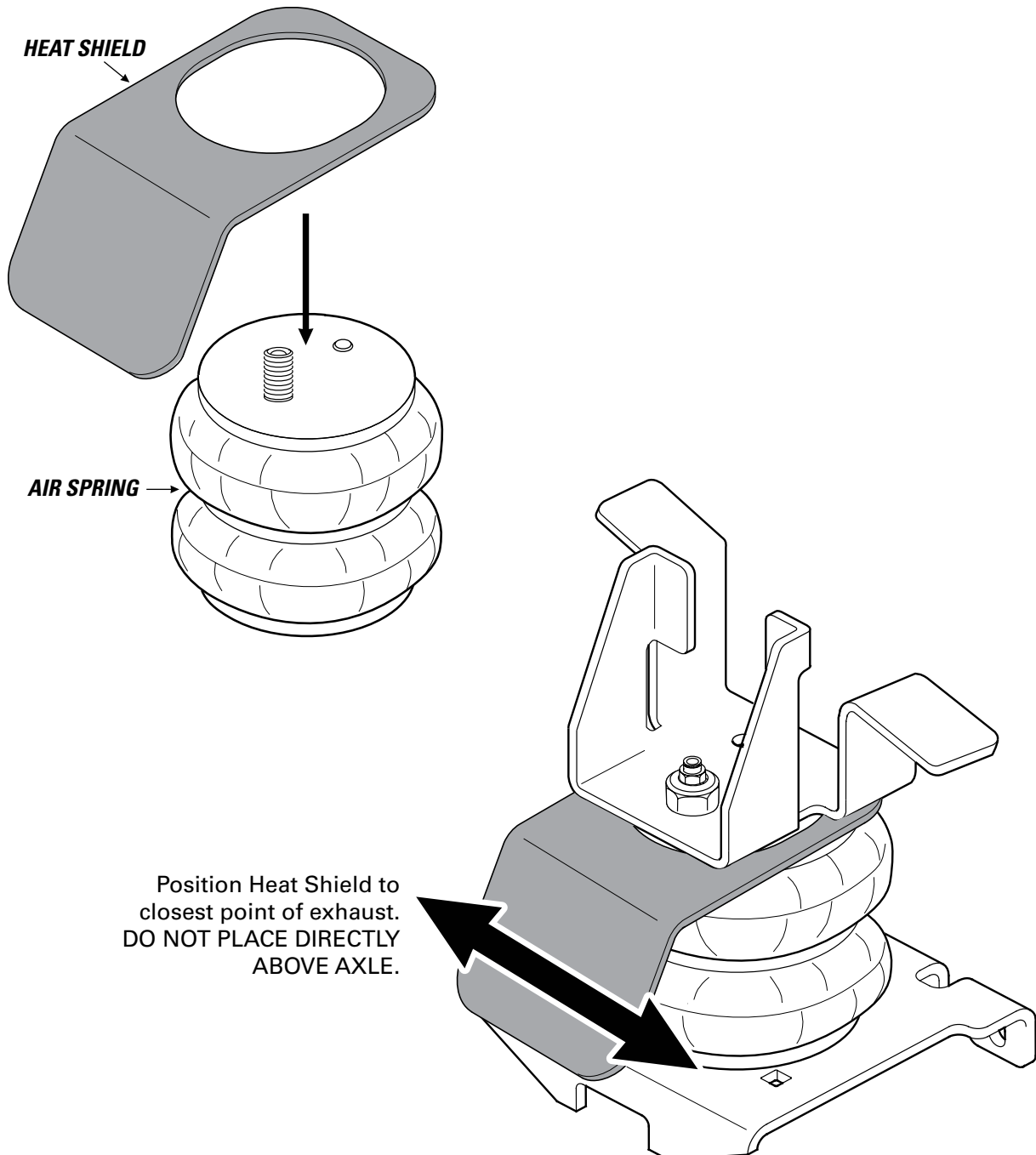







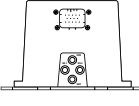
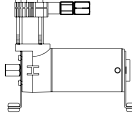
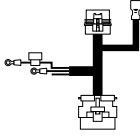
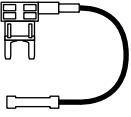
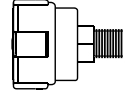



SECTION 2 PARTS

Compare the parts below to your kit. Assure you have all pieces, and organize them for an easier installation.

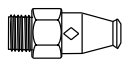
AIR ACCESSORY CONTENTS

PART # 9490		x1 WIRELESS CONTROLLER	PART # 9489		x1 ECU	PART # 9377		x1 AIR COMPRESSOR
PART # 9491		x1 WIRE HARNESS	PART # 2526		x1 IGNITION FUSE TAP	PART # 9129		x1 AIR FILTER

AIR ACCESSORY HARDWARE PACK

PART # 3087		x4 10-32 x 1" MACHINE SCREW	PART # 3093		x3 10-32 x 3/4" MACHINE SCREW	PART # 3086		x13 3/16" FLAT WASHER
PART # 3088		x7 10-32 NYLOCK NUT	PART # 3055		x1 1/8 NPT PUSH-TO-CONNECT STRAIGHT FITTING	PART # 9361		x1 SEALED RELAY
PART # 3421		x1 10-16 x 3/4" SELF-TAPPING SCREW	PART # 9275		x4 VELCRO TABS	PART # 9036		x15 RED NYLON TIE
PART # 9488		x4 LARGE NYLON TIE	PART # 0899		x2 THERMAL SLEEVE			

CONTENTS AND OVERVIEW

SECTION 2

PAGE **12** PLANNING THE INSTALL

PAGE **13** PREPARE THE AIR COMPRESSOR

PAGE **14** DRILL HOLES FOR AIR COMPRESSOR AND ECU

PAGE **15** INSTALL THE AIR COMPRESSOR AND ECU

PAGE **16** INSTALL THE WIRE HARNESS

PAGE **17** INSTALL THE AIR LINE TUBES

PAGE **18** INSTALL THE AIR FILTER AND CLEAN UP

PAGE **19** ADJUSTING AIR PRESSURE AND UNITS

PAGE **20** WIRELESS CONTROLLER MEMORY SETTINGS AND ERROR CODES

PAGE **21** TEST THE SYSTEM

PAGE **22** FIX AN AIR LEAK

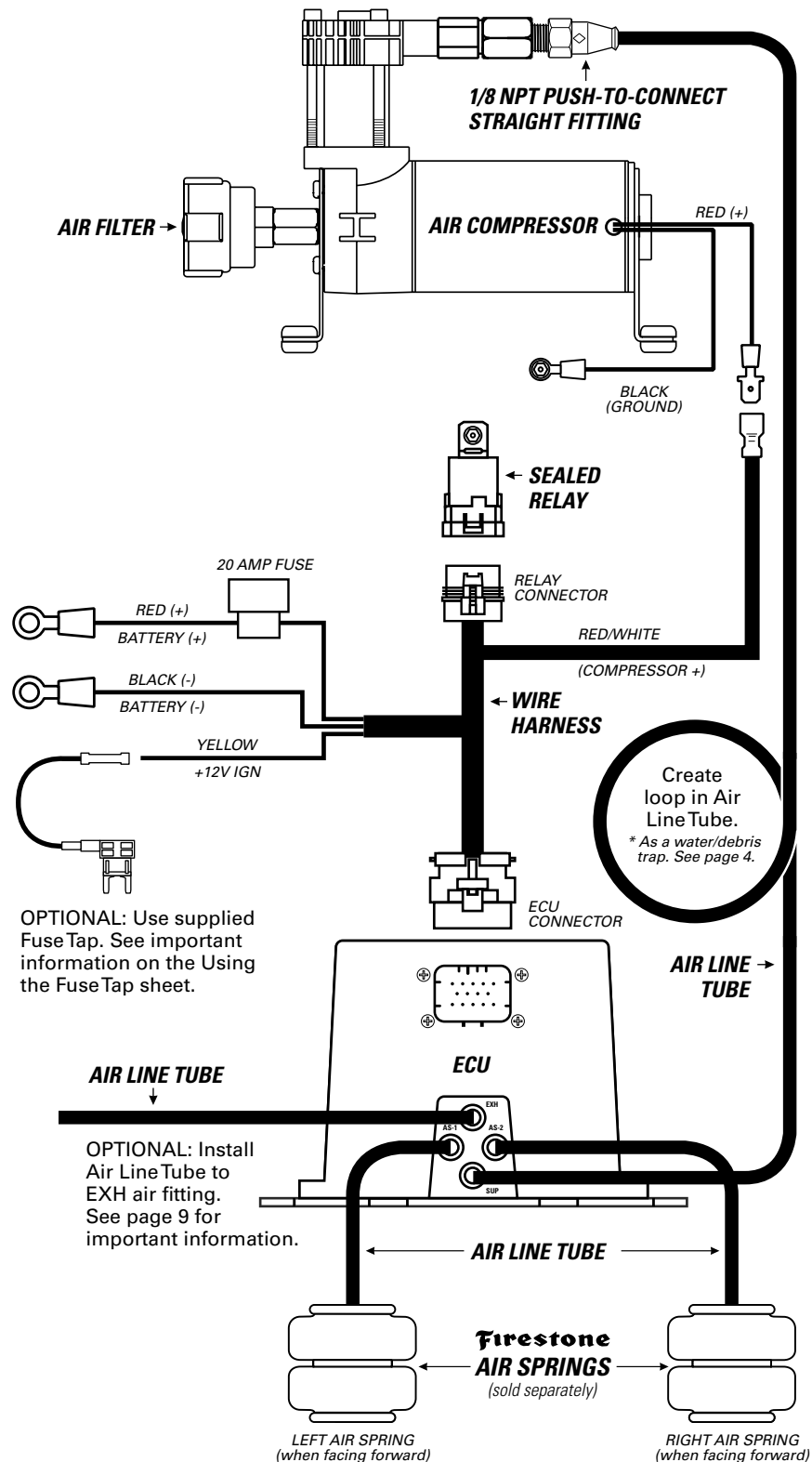

PLANNING THE INSTALL

THESE PLANNING STEPS WILL HELP YOU SAVE TIME AND WILL MAKE THE INSTALLATION EASIER.

DETERMINE THE MOUNTING LOCATION FOR THE AIR COMPRESSOR

- Provides ample air flow and is protected from airborne debris and moisture.
- Mount close enough to the ECU to allow Wire Harness connections to reach.
- If using the optional Firestone Air Accessory Mounting Kit, consider the guidelines above, and follow the kit's instructions.

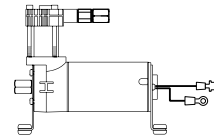

DETERMINE THE MOUNTING LOCATION FOR THE ECU

- Mount close enough to the Air Compressor to allow Wire Harness connections to reach.
- Allow room for Air Line Tubes to connect to the air fittings on the ECU.
- Allow room for the 14-pin ECU connector to connect to the ECU.
- Allow room for the Air Line Tube to run without sharp curves or bends.
- Using supplied fasteners shown in Step 3 is recommended. If no other mounting option is available, see the sidebar on Step 2 for using the Large Nylon Ties.
- Select a location that is solid and secure on the body or frame of the vehicle, away from any moving parts, electrical or any other lines.

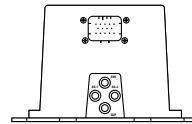

PLAN INSTALLATION ROUTES FOR WIRING AND AIR LINES

- Make sure the Wire Harness and Air Line Tubes are not exposed to sharp metal edges that can damage them.
- Use supplied Thermal Sleeves on Air Line Tubes when routing near heat sources.
- Use supplied Nylon Ties to secure Air Line Tubes and Wire Harness to the vehicle.
- Make a loop in the Air Line Tube where shown. This creates a water/debris trap that protects the Air Compressor.
- Measure twice, cut once!

TAPE ALL ELECTRICAL CONNECTIONS

- Use electrical tape to appropriately secure and protect all electrical connections.

USING PUSH-TO-CONNECT FITTINGS FOR AIR LINES

Your kit includes Push-to-Connect fittings to connect the Air Line Tubes to hardware. Use the instructions below when using the Air Line Tubes.

- 1** Insert end of Air Line Tube into air fitting.

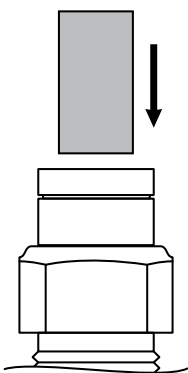

- 2** Push Air Line Tube into air fitting as far as possible.

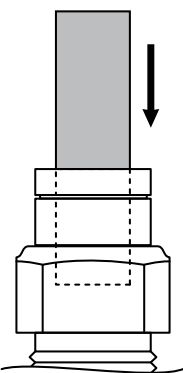

- 3** Gently pull on the Air Line Tube to check for a secure fit.

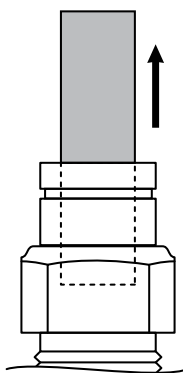

- 4** To remove, push down collar and gently pull Air Line Tube away.

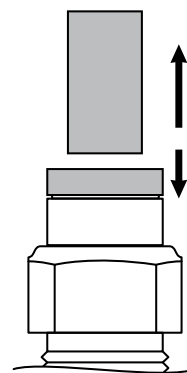

Removal Tip: Use a 1/4", 5/16", or 6mm open-ended wrench to push the collar down.

1

PREPARE THE AIR COMPRESSOR

NOTE: Air Compressor can be mounted facing any direction.

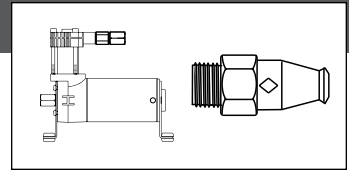

- 1 Install 1/8 NPT Push-to-Connect Straight Fitting on the Check Valve.

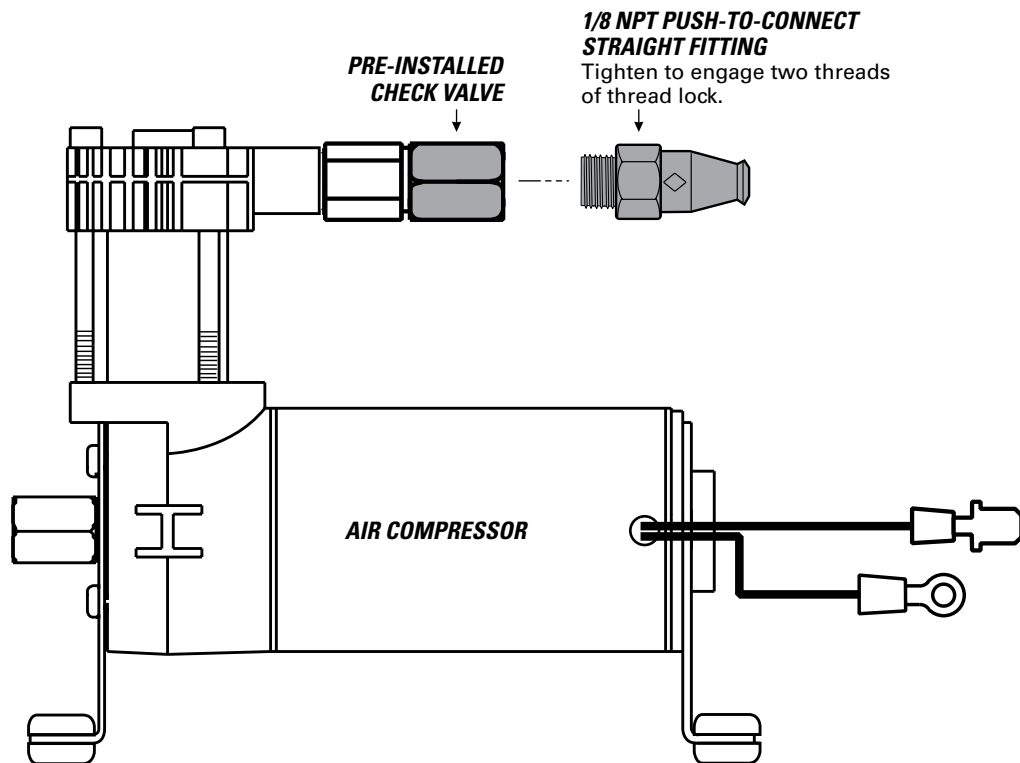

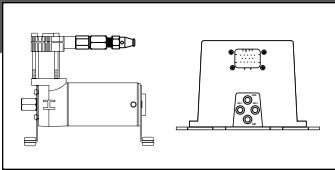

CHECK SURROUNDING AREA AND BACK SIDE OF MOUNTING LOCATION TO AVOID DRILLING INTO EXISTING LINES OR WIRING.



IF YOU ARE USING THE OPTIONAL FIRESTONE AIR ACCESSORY MOUNTING KIT, SKIP THIS STEP AND REFER TO THE MOUNTING KIT'S INSTRUCTIONS.

Drill within reach of the ground wire ring terminal on body or frame of vehicle. **AIR ACCESSORY MOUNTING KIT CANNOT BE USED AS A GROUNDING LOCATION FOR THE AIR COMPRESSOR.**

1 Using the Air Compressor and ECU as templates, mark drill locations as shown with a punch or marking tool.

2 Mark Air Compressor ground wire fastening location within reach of the ground wire ring terminal.

3 Drill 3/16" diameter holes. Remove any burrs and debris from drill holes.

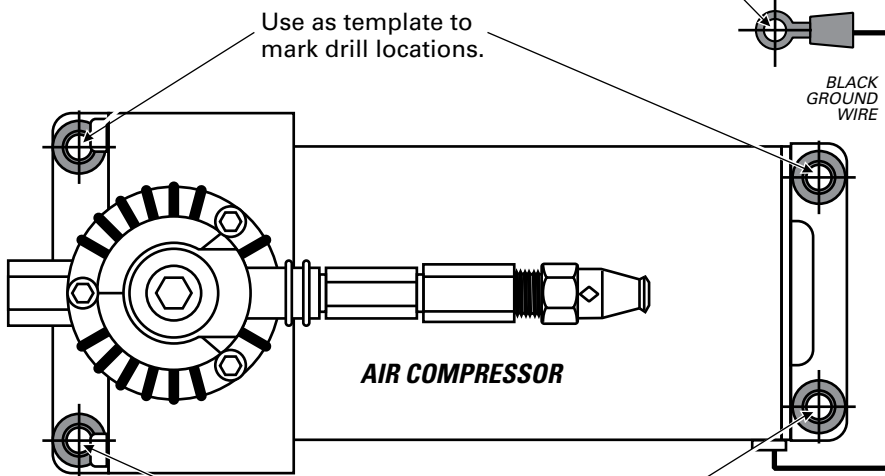

ASSURE THAT YOU INSTALL THE AIR COMPRESSOR AND ECU CLOSE ENOUGH SO THE CONNECTORS ON THE WIRE HARNESS WILL REACH THEM BOTH.

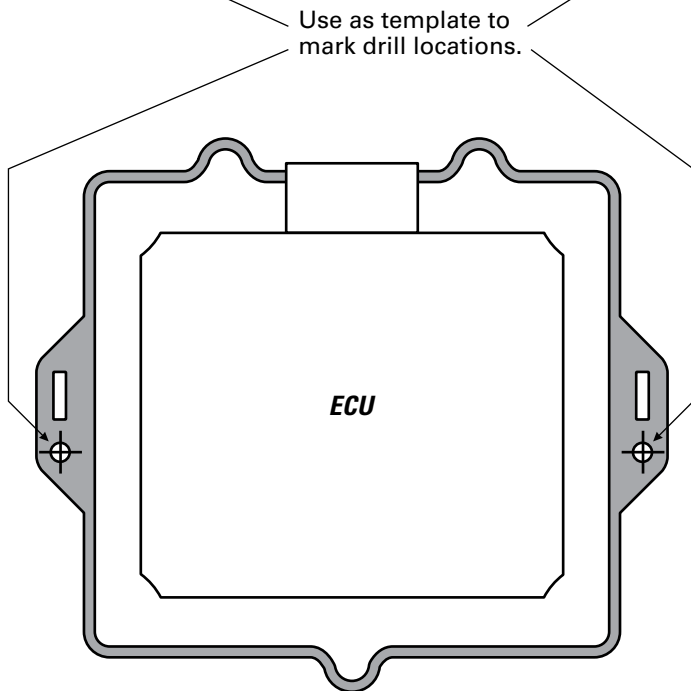

OPTIONAL ECU MOUNTING

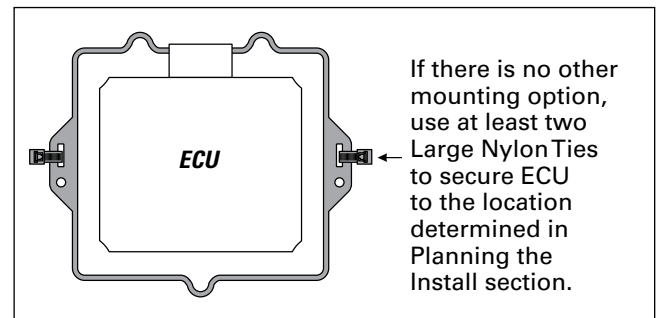

3

INSTALL THE AIR COMPRESSOR AND ECU

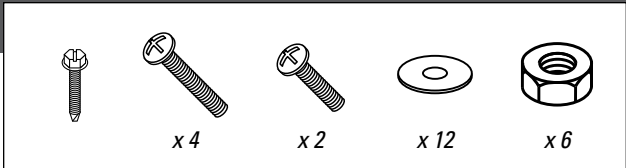

DO NOT OVER TIGHTEN MOUNTING BOLTS AND NUTS ON THE AIR COMPRESSOR. TOO MUCH TORQUE CAN CRUSH THE BRASS INSERTS AND RUBBER ISOLATORS.

1 Mount the Air Compressor to the drill hole location using the supplied fasteners. DO NOT OVERTIGHTEN.

2 Mount the ECU to the drill hole location using the supplied fasteners.

3 Mount the black ground wire ring terminal using the supplied fasteners. Assure that the ring terminal makes a solid contact with bare metal for a proper ground.

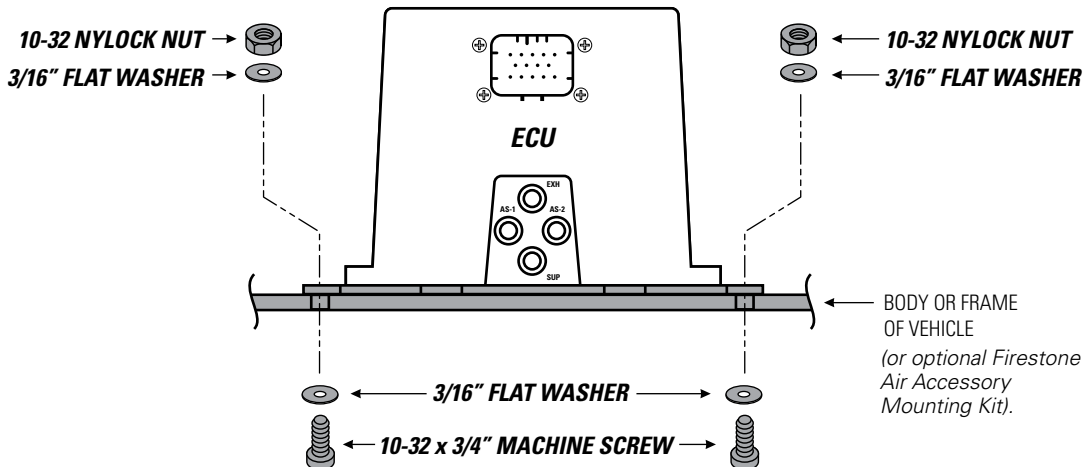
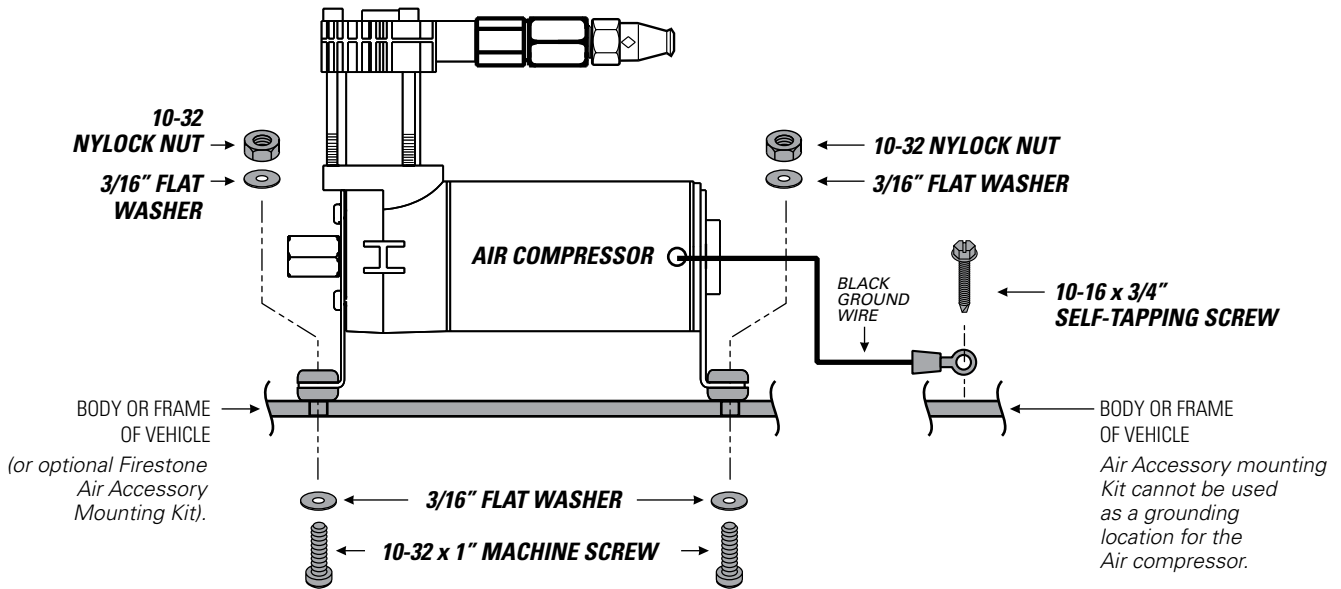

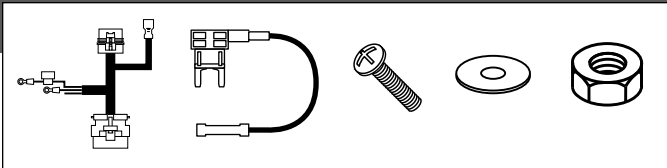

Why ground the Wire Harness to the battery? The ECU needs a good, clean ground for optimal accuracy. The Air Compressor can ground to the frame, but the ECU cannot.

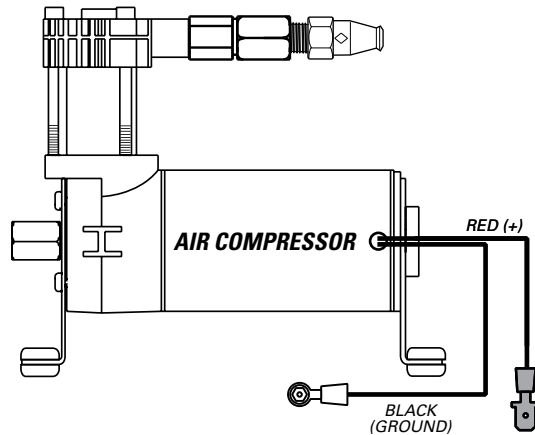

10-32 NYLOCK NUT
3/16" FLAT WASHER
10-32 x 3/4" MACHINE SCREW

← SEALED RELAY

Drill 3/16" hole in suitable location on vehicle (or use optional Firestone Air Accessory Mounting Kit).

- 1 Determine a suitable location to mount the Sealed Relay, assuring it will be within reach of the relay connector on the Wire Harness.
- 2 Securely fasten the Sealed Relay as shown.
- 3 Route the Wire Harness in the most protected manner possible, and securely make all connections as shown.

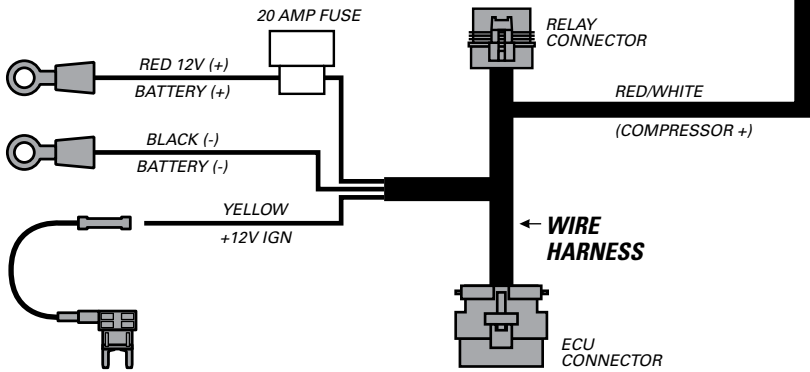

OPTIONAL: Use supplied Fuse Tap. See important information on the Using the Fuse Tap sheet.

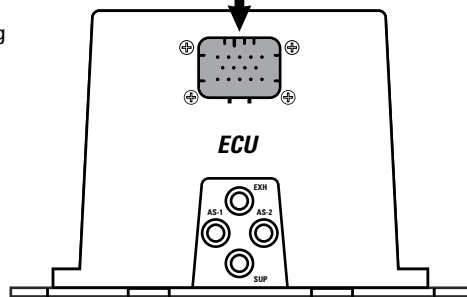

TAB CONNECTOR EXAMPLE

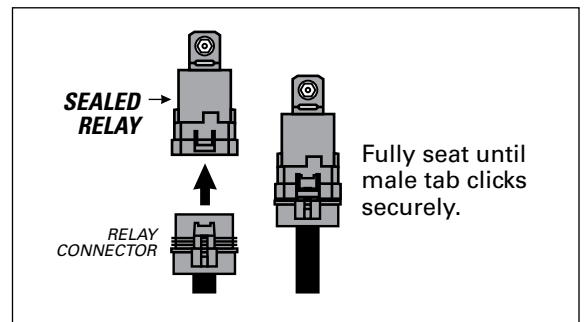

5

INSTALL AIR LINE TUBES



EXHAUST ALL AIR FROM THE SYSTEM PRIOR TO RELEASING AIR TUBES FROM AIR FITTINGS.

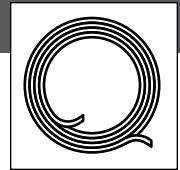

1 Route the Air Line Tube from 1/8 NPT Push-to-Connect Straight Fitting on the top of the Air Compressor to the Supply (SUP) air fitting on the ECU, leaving room to secure it safely. Use the guidelines on page 4 for proper Push-to-Connect Straight Fitting install.

2 Repeat Steps 1 to route Air Line Tube from the ECU to the Air Springs. Use the AS-1 and AS-2 air fittings on the ECU.

3 If desired, install Air Line Tube to the Exhaust (EXH) air fitting to reduce exhaust noise and prevent dirt from clogging the port (recommended for off-road or dirty environments). Do not exceed 16" of Air Line Tube, and secure it so the end turns to the ground.

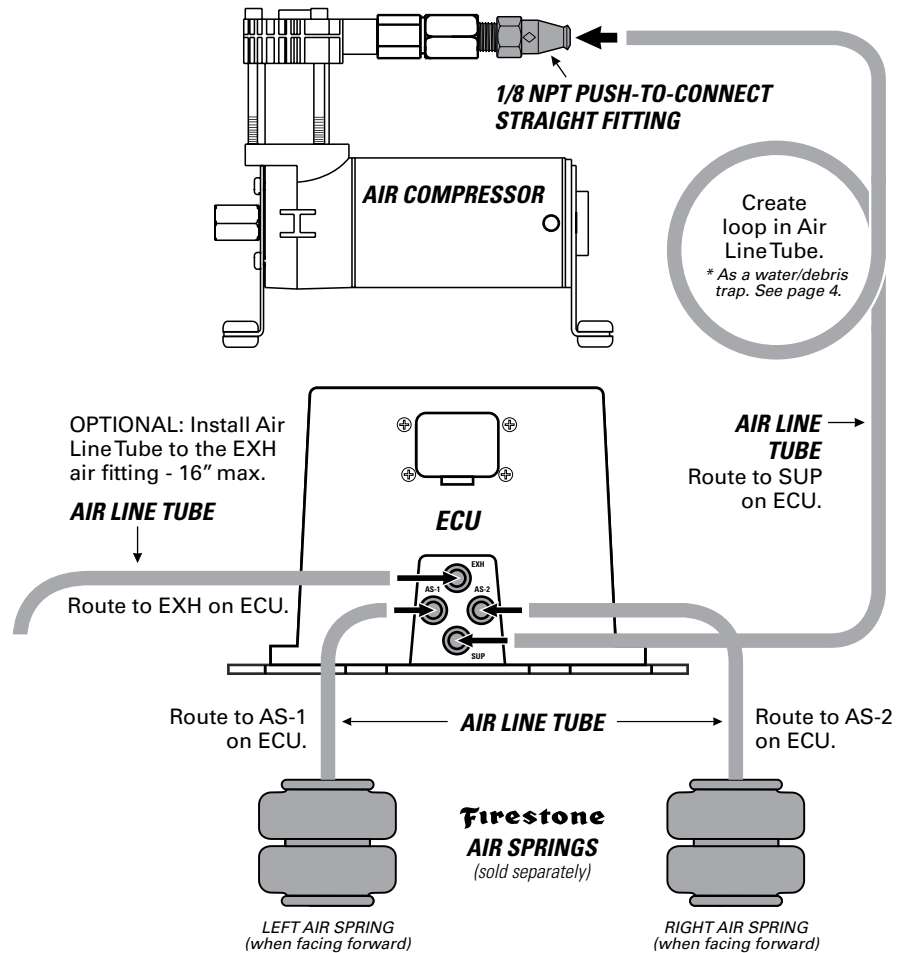

DO

Make sure the cut is as square as possible. Use a tube cutter or very sharp utility knife.

DON'T

Fold or kink the Air Line Tube. Cut the Air Line Tube at an angle. Use pliers, scissors, snips, saws, or side cutters.

PROPER AND IMPROPER CUTS IN THE AIR LINE TUBE

<p>Square cut AIR LINE TUBE 90°</p>	<p>AIR LINE TUBE</p>	<p>AIR LINE TUBE</p>	<p>AIR LINE TUBE</p>
---	----------------------	----------------------	----------------------

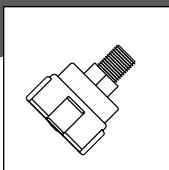

- 1 Install the Air Filter by threading it onto the Air Compressor as shown.

- 2 Periodically check the Air Filter during operation. When the Air Filter is dirty and needs to be replaced, contact an Authorized Firestone dealer to purchase a new one.



FILTER LIFE WILL VARY BASED ON ENVIRONMENTAL CONDITIONS. PROTECT THE AIR COMPRESSOR BY CHANGING THE AIR FILTER MORE FREQUENTLY IN DUSTY CONDITIONS.

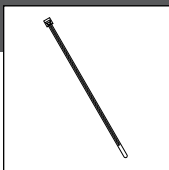
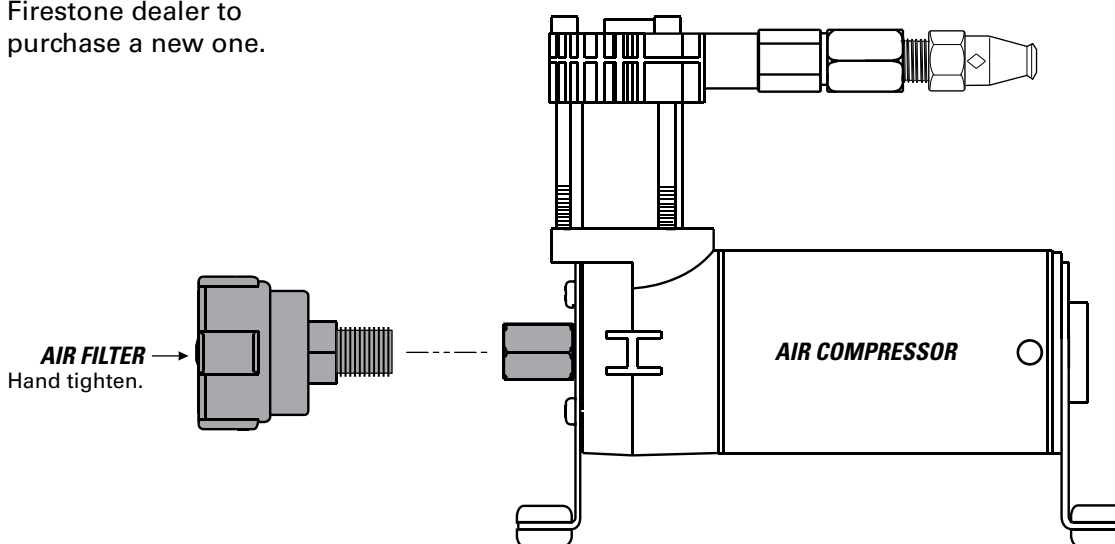

- 1 Clean up the installation using supplied Nylon Ties, and return all factory parts and materials to operative state.



USING SUPPLIED NYLON TIES, SECURE ALL WIRING AND AIR LINE TUBE IN A MANNER THAT DOES NOT OBSTRUCT MOVING PARTS OR IN ANY WAY THAT AFFECTS YOUR ABILITY TO SAFELY OPERATE THE VEHICLE.

8

ADJUSTING AIR PRESSURE AND UNITS

Use the Wireless Controller to adjust the air pressure in your Air Springs. You can select the Air Springs individually, or both at the same time. Determine sides when in vehicle, facing forward. If desired, use the supplied Velcro Tabs to secure the remote to the vehicle.



1 Select Air Spring(s) for pressure adjustment by pressing the Enter  Button once for AS-1 (left side), twice for AS-2 (right side) or three times for both sides.

2 Press the + Button to increase pressure in selected Air Spring(s).

3 Press the - Button to decrease pressure in selected Air Spring(s).

4 Press the Enter  Button to activate the system.

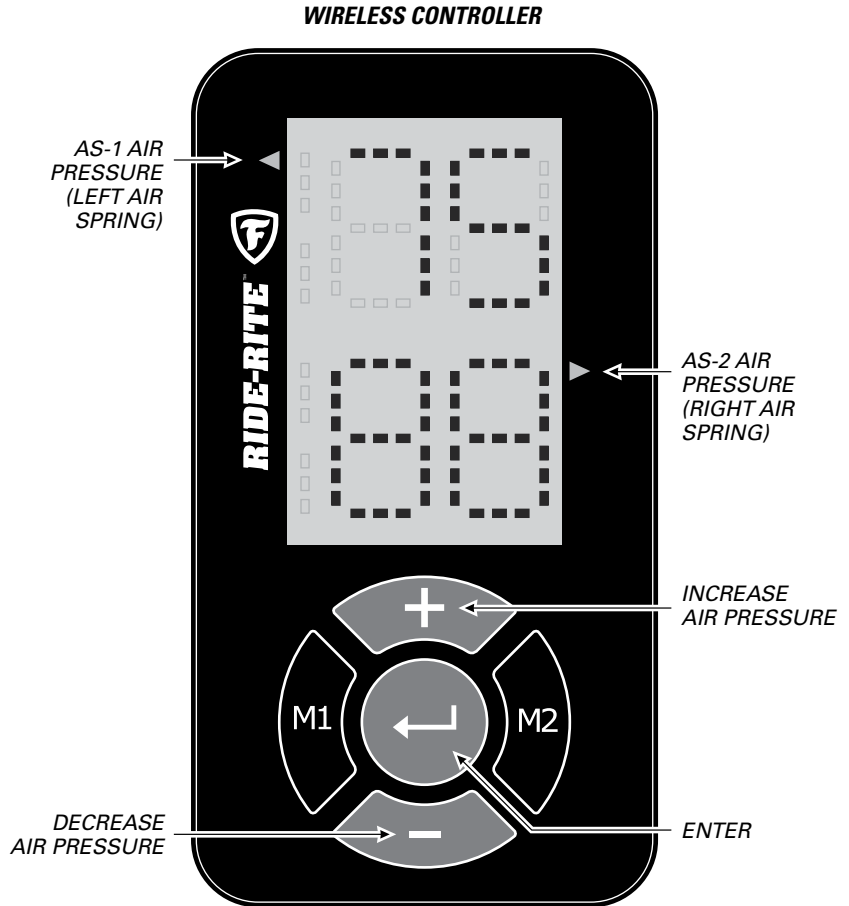

WAIT, THERE'S BAR!

The Wireless Controller settings default to PSI units, but you can adjust the units by following the steps below.

1 Push any button to power on the Wireless Controller and make sure none of the units on the display are flashing.

2 Hold down the Enter  Button for a few seconds.

3 Use either the + or - Button to select PS for PSI or BR for BAR. Press Enter  Button to finalize selection.



You can set up to 2 memory settings for the system for quick adjustment to frequently used Air Spring settings. M1 is preset for 5 PSI and M2 is preset for 20 PSI.

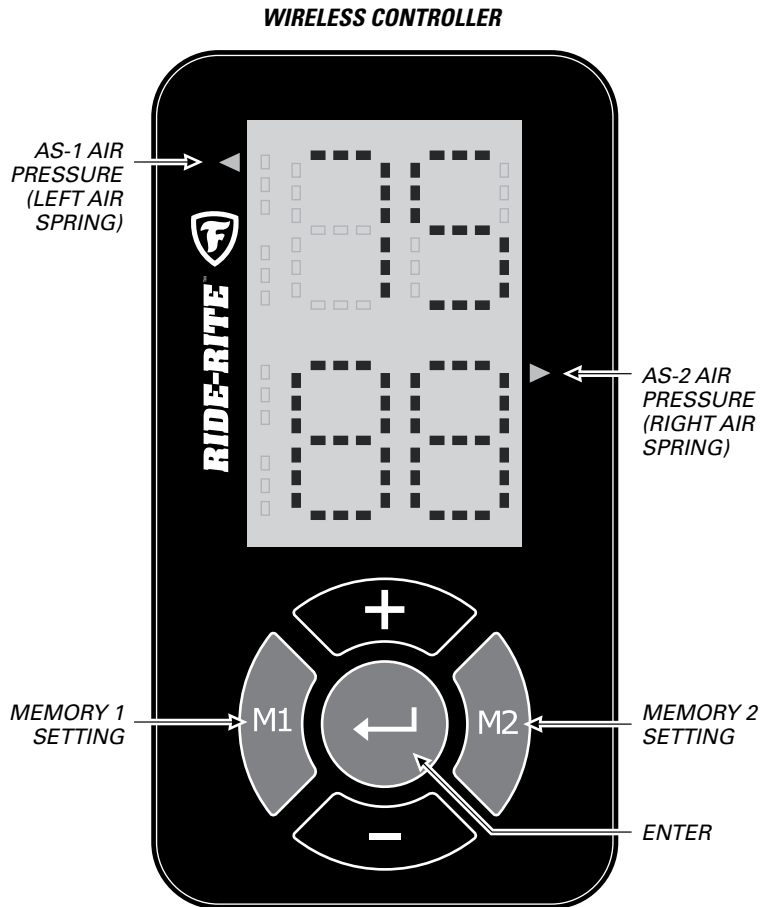

- 1** Complete Step 8 to adjust the Air Spring air pressures to desired settings.
- 2** Press and hold the **M1** Button for 3 seconds to save the displayed Air Pressure settings to the M1 memory.
- 3** Repeat steps 1 and 2 with the **M2** Button to save an M2 memory setting.
- 4** To activate a memory setting, push the desired Memory Button, either **M1** or **M2**.
- 5** Within one second of pressing **M1** or **M2**, press the Enter  Button.

OOPS, SOMETHING WENT WRONG!

Reference the Error Codes below to troubleshoot the problem.

EO

- Check power on the ECU (red and yellow wires need +12VDC).
- Check ground for the ECU (black wire should be attached to the negative battery terminal).
- Check your wires for any abrasion or heat damage between the ECU and the battery/fuse box.
- Make sure the Wireless Controller is in range of the ECU (25 ft.). Note that range will vary depending on line-of-sight restrictions.

LO BR

- The batteries in your Wireless Controller are low.
- Replace both CR2032 coin-cell batteries.

10

TEST THE SYSTEM

With the Air Command™ F3 Kit and your Air Springs installed, you are ready to test the system.

- 1** Reattach the negative battery cable.

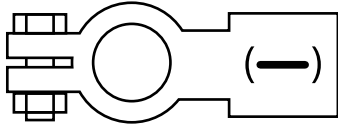

- 2** Turn on your vehicle's ignition.

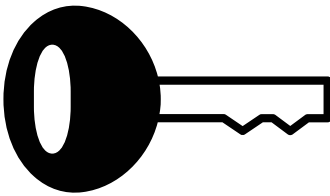

- 3** Use the Wireless Controller to inflate the Air Springs to 70 PSI. See Step 8 for details.

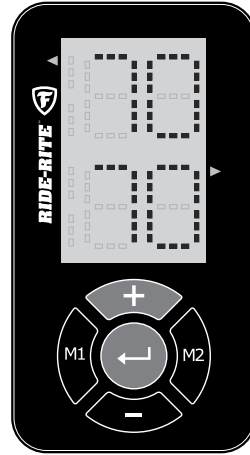

- 4** Spray fittings with soap and water mixture or glass cleaner.



- 5** Observe bubbles.

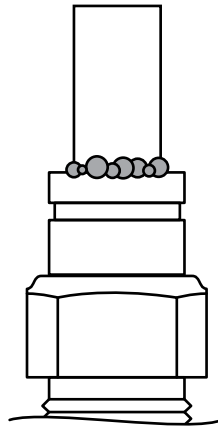

SMALL SOAP BUBBLES THAT DO NOT EXPAND

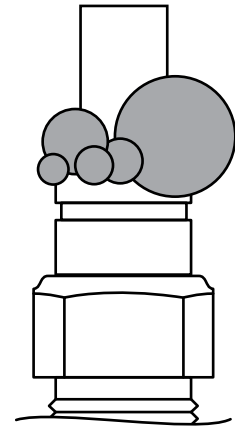

SOAP BUBBLES THAT EXPAND



NO LEAKS?

Congratulations! You're riding right with the push of a button! Remember to review the Operating Instructions.

LEAK?

Bummer. Continue to Step 11 to fix the leak.



EXHAUST ALL AIR FROM THE SYSTEM PRIOR TO RELEASING AIR TUBES FROM AIR FITTINGS.



- 1 Use the Wireless Controller to deflate the Air Springs to 5 PSI. See Step 8 for details.

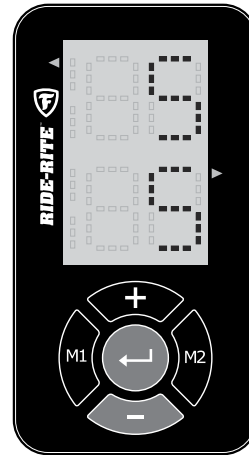

LEAK AT AIR LINE TUBE AND AIR FITTING

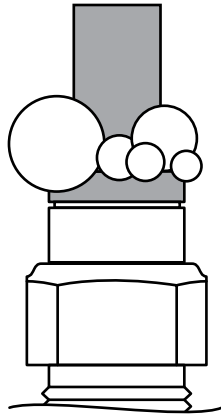

Release Air Line Tube (see page 12). Review proper cuts and procedures in Step 5. Repeat Step 5.

LEAK AT BASE OF AIR FITTING

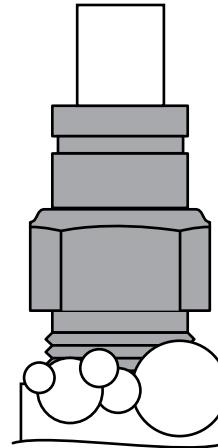

Tighten Air Fitting one turn or until leak stops.

STILL HAVE A LEAK?

Refer to the Troubleshooting section of the Instruction Manual. If the leak persists, or if there is an issue with a leaking part, call 1-800-888-0650; Option 1; Option 1 for Tech Support.



riderite.com

SAFELY RETURN VEHICLE TO OPERATIVE STATE

If you removed any wheels during installation, install the wheels and torque the lug nuts to the manufacturer's specifications. Safely remove any jack stands and wheel chocks used during installation. Re-attach the negative battery cable.

READ AND UNDERSTAND THE OPERATING INSTRUCTIONS

The Ride-Rite system can improve handling and comfort. Take the time to learn how to properly use and maintain your investment by reading the Operating Instructions.

BEFORE YOU DRIVE, CONFIRM THE FOLLOWING:

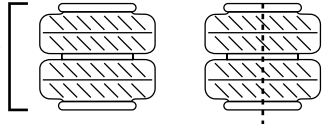
- Do you have a minimum of 5PSI in your Air Springs?
- Are your Air Springs standing 5 1/2" - 6 1/2" tall? 
- Are your Air Springs properly aligned, left-to-right and front-to-back?
- Are your nuts and bolts tight?
- Put your paper work back into the sleeve and keep it in your glove compartment for future reference.
- Secure all Air Line Tubes and wiring.
- The system passes the leak test and holds air.
- The Air Compressor ground ring terminal is contacting bare metal, and coated with silicone if possible.
- The Wire Harness is grounded to the negative (-) battery terminal. The ECU needs a good, clean, interference-free ground.
- There is a loop in the Air Line Tubes as shown to prevent water or debris from getting into the Air Compressor head and damaging it.
- You've been bagged...and now your suspension is Airide equipped! Show it off with the supplied decal!

NEED INSTALLATION HELP? 1-800-888-0650

Select Option 1 for Ride-Rite; Select Option 1 for Technical Support.

Or, email us at rrtech@fsip.com. If emailing, please include photos to help us better diagnose and understand any problems you may be experiencing.



CONNECT WITH US



@rideriteair



@rideriteair



Firestone RideRite



Firestone Ride-Rite