



**Installation Manual v1.0:  
ATS High Capacity Transmission Pan  
Dodge Automatic Transmissions**

**Please read all instructions before installation.**

**If transmission temperatures run too high, consider ATS Transmission Coolers, Thermostats and Transmission Temperature Gauges for transmission temperature control and monitoring.**

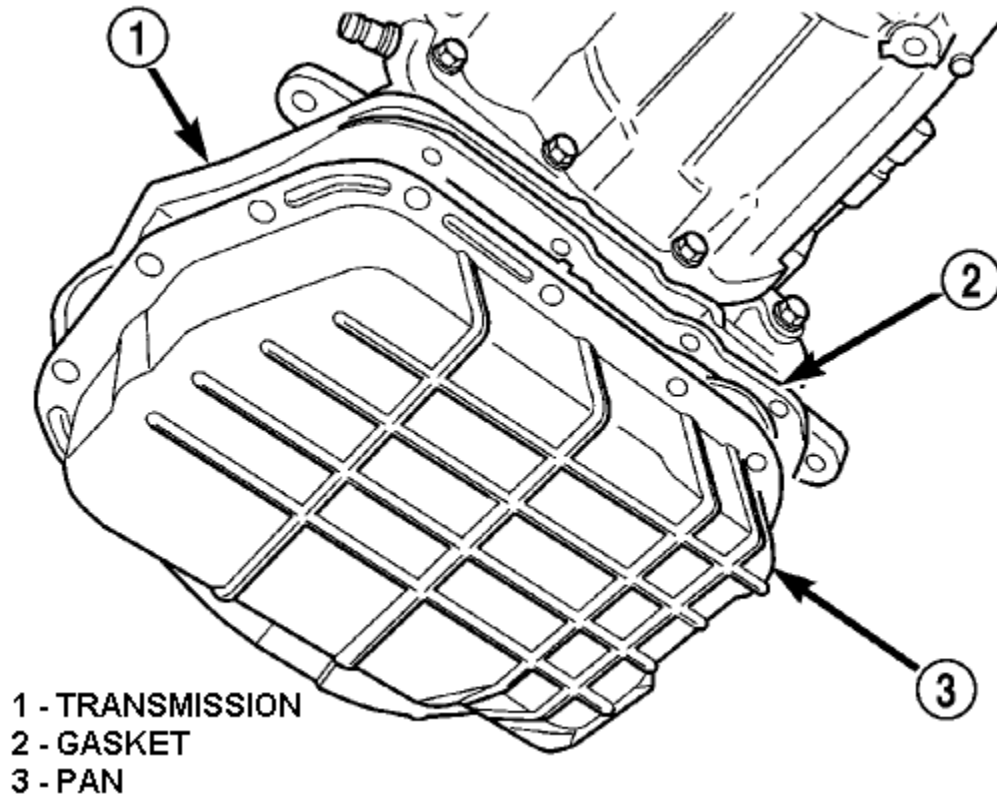


**Figure 1: Dodge ATS High Capacity Transmission Pan**

1. Please make sure no parts are missing out of the ATS High Capacity Transmission Pan kit. A complete corresponding list of parts can be

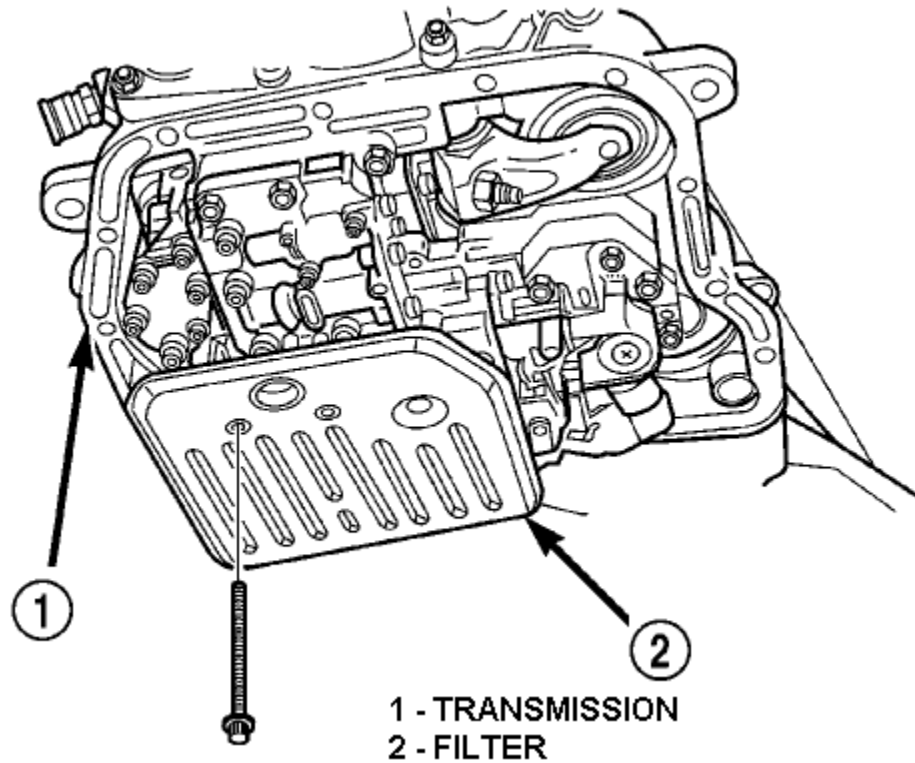
found on page 8. The bag pictured contains all hardware necessary for installation.

2. Hoist and support vehicle on safety stands. Disconnect negative (-) battery cables and secure away from negative terminals.
3. Position a large diameter shallow drain pan beneath factory transmission to catch the old automatic transmission fluid.
4. Remove bolts holding front and sides of factory pan to transmission.



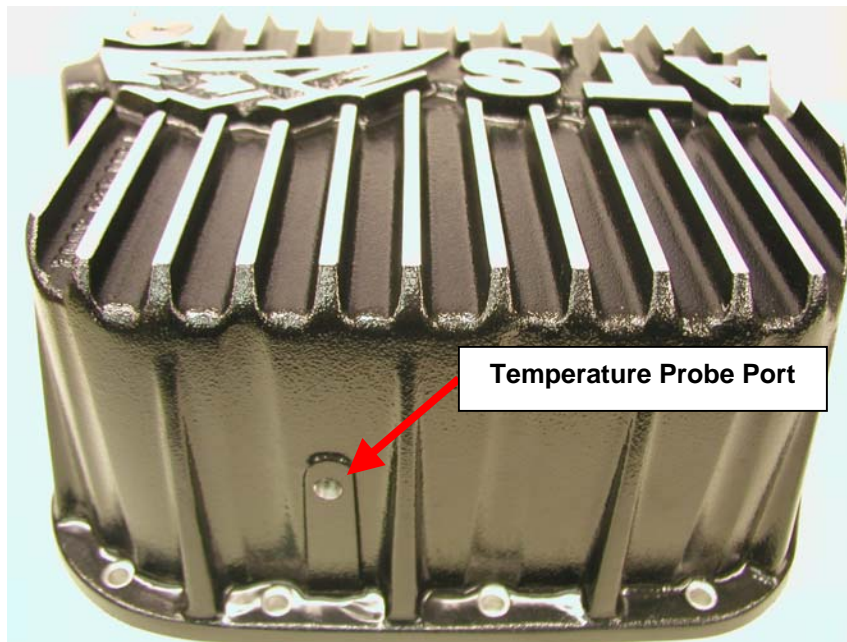
**Figure 2: Gasket and Transmission Pan Assembly**

5. Loosen bolts holding rear of factory pan to transmission.
6. Slowly separate front of factory pan and gasket away from transmission allowing fluid to pour into drain pan.
7. Hold up factory pan and remove remaining bolt holding pan into transmission.
8. Pour remaining fluid in factory pan into drain pan.
9. Remove screws holding filter to valve body.



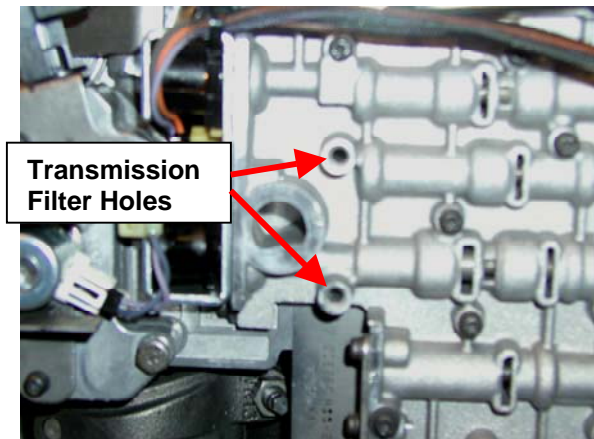
**Figure 3: Screw and Filter Removal**

10. Separate filter from valve body and pour fluid in filter into drain pan.
11. Inspect bottom of pan and magnet for excessive amounts of metal or fiber contamination. A light coating of clutch or band material on bottom of pan does not indicate a problem unless accompanied by slipping condition or shift lag. If fluid and pan are contaminated with excessive amounts or debris, contact a professional for advice and/or assistance.
12. Align transmission pan gasket holes with holes in ATS High Capacity Transmission Pan. Align ATS High Capacity Transmission Pan and gasket with bolt holes in transmission. Thread new stainless steel cap screws in transmission until finger tight. Torque all cap screws to **13 ft-lbs** in a crisscross pattern.
13. If not already installed, install drain plug and torque plug to **15 ft-lbs**.
14. If you plan to install a thermostat, install thermostat in temperature probe port located at front of ATS High Capacity Transmission Pan. To install, apply anti-seize compound to threads of thermostat probe and torque probe to **10 ft-lbs**. If not, install 1/8 pipe plug in temperature probe port and torque to **10 ft-lbs**.

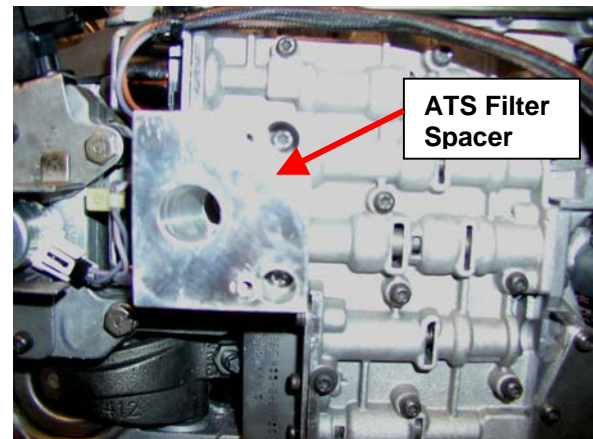


**Figure 4: Temperature Probe Port**

15. Bolt transmission filter spacer to valve body using filter screws so "FRONT" engraving faces front of vehicle. Torque screws to **3 ft-lbs**.

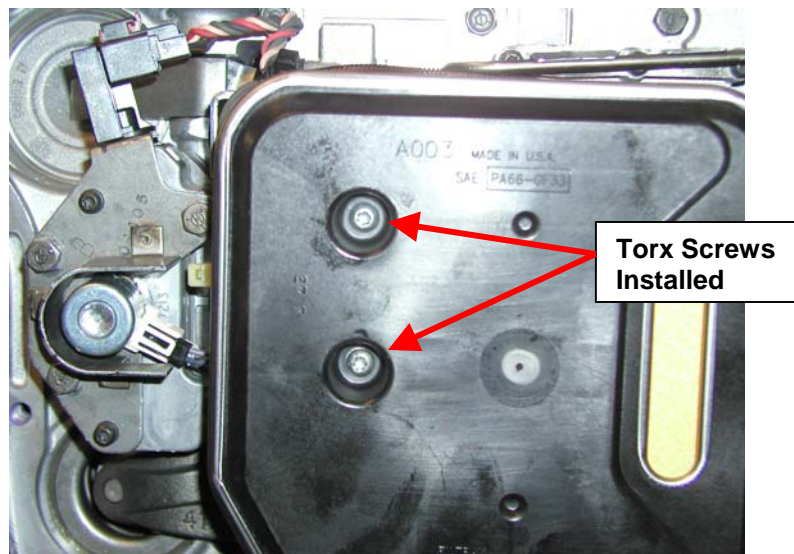


**Figure 5: Filter Mount Holes**



**Figure 6: Filter Spacer**

16. Position a new transmission oil filter onto the filter spacer.
17. Thread torx screws into filter spacer through holes in transmission filter. Torque screws to **3 ft-lbs**.



**Figure 7: Transmission Filter Installed**

18. Clean gasket surfaces of new transmission oil pan and transmission pan rail.
19. Align gasket holes with holes in the ATS High Capacity Transmission Pan.
20. Position ATS High Capacity Transmission Pan and gasket onto transmission and install several stainless steel cap screws to hold pan and gasket to the transmission.
21. Install remaining stainless steel cap screws and torque each cap screw to **13 ft-lbs** in a crisscross pattern.
22. Lower vehicle back to ground level and apply parking brake.
23. Reconnect battery cables.
24. To fill transmission, remove dipstick and insert clean funnel in transmission fill tube.
25. Add following initial quantity of Mopar ATF +4, automatic transmission fluid, to transmission:
  - a. If only fluid and filter were changed, add **5** quarts of ATF +4 to transmission
  - b. If transmission was completely overhauled, or torque converter was replaced or drained, add **9.5** quarts of ATF +4 to transmission.

**Note:** Due to some factory options, fluid amounts can vary. Consult owner's manual for reference.

26. Remove funnel and insert dipstick.
27. Start and run engine at normal idle.
28. Apply brakes, release parking brake, shift transmission through all gear ranges checking for engagement, then back to **NEUTRAL** and set parking brake. Leave engine running at idle until transmission reaches normal operating temperature (**150-170°F**).
29. Check fluid level. If level is low, add fluid in increments of **0.25 quarts** to bring level to **MIN** mark on dipstick. Check to see if oil level is equal on both sides of dipstick. If one side is noticeably higher than other, the dipstick has picked up some oil from the dipstick tube. Allow oil to drain down dipstick tube and re-check. Add fluid until the correct level is achieved (fluid should be up to **MAX** arrow mark on dipstick).
30. Do not overfill transmission; fluid foaming and shifting problems can result.
31. Pour used transmission fluid into approved container and dispose of fluid at appropriate recycling facility or participating local parts store.

**A word of caution to the vehicle owner/installer:**

In some applications, or because of the use of certain factory options and/or aftermarket equipment, clearance problems can occur between the ATS High Capacity Transmission Pan and other vehicle systems. It is the responsibility of the vehicle owner/ installer to ensure no other vehicle component comes in contact with the ATS High Capacity Transmission Pan. **Contact with any vehicle component, or the making of any modifications to the ATS High Capacity Transmission Pan, automatically voids the warranty. ATS Diesel Performance assumes no liability, expressed or implied, for damage or injury to persons or property.**

## **Have Any Questions?**

Thank you for purchasing the ATS High Capacity Transmission Pan. Please check our website at <http://www.atsdiesel.com> for technical support and other performance products such as the 5-Star™ torque converter, ATS High Performance Valve Body and ATS High Performance Transmission along with our full line of power enhancers. Please call or e-mail our Technical Service Department, 8:00am to 5:30pm Mountain Standard Time, Monday through Friday.

### **Contact Information**

Toll Free: 800-949-6002

Local: 303-431-7973

Fax: 303-431-01135

Website: [www.ATSDiesel.com](http://www.ATSDiesel.com)

Email: [info@ATSDiesel.com](mailto:info@ATSDiesel.com)

We strive to make our instructions as clear and complete as possible. To achieve this, our instructions are under constant construction. We encourage you to visit our Technical Support Website (<http://www.atsdiesel.com/ATSWebsite/Technical.asp>) to check for the most up-to-date manuals and diagrams as well as other information. If you have any suggestions as to how we can improve this installation manual, let us know at <mailto:Suggestions@ATSDiesel.com>.

**Bill of Materials**

1. ATS High Capacity Transmission Pan 2116-301-100
2. Gasket (Axiom p/n 22300F)
3. Transmission Filter Spacer
  - (1) Transmission Filter Spacer
  - (2) Torx Mounting Screws
4. Hardware Bag
  - (14) Stainless Steel Cap Screws (5/16-18 x 7/8)
  - (14) 5/16 Washers (not pictured)
  - (1) 1/8 Pipe Plug
5. Magnetic Drain Plug
  - (1) Drain Plug
  - (1) O-Ring

Not Pictured

6. Instruction Manual 2116-301-900 – INST
7. ATS Warranty [www.atsdiesel.com/warranty](http://www.atsdiesel.com/warranty)