



# 20250 MODULE

## INSTALLATION GUIDE

— 2013.5–2017 —  
RAM 6.7L CUMMINS

UP TO 90HP GAIN  
1-3 MPG FUEL SAVINGS



[AGDIESELSOLUTIONS.COM](http://AGDIESELSOLUTIONS.COM)

YouTube 

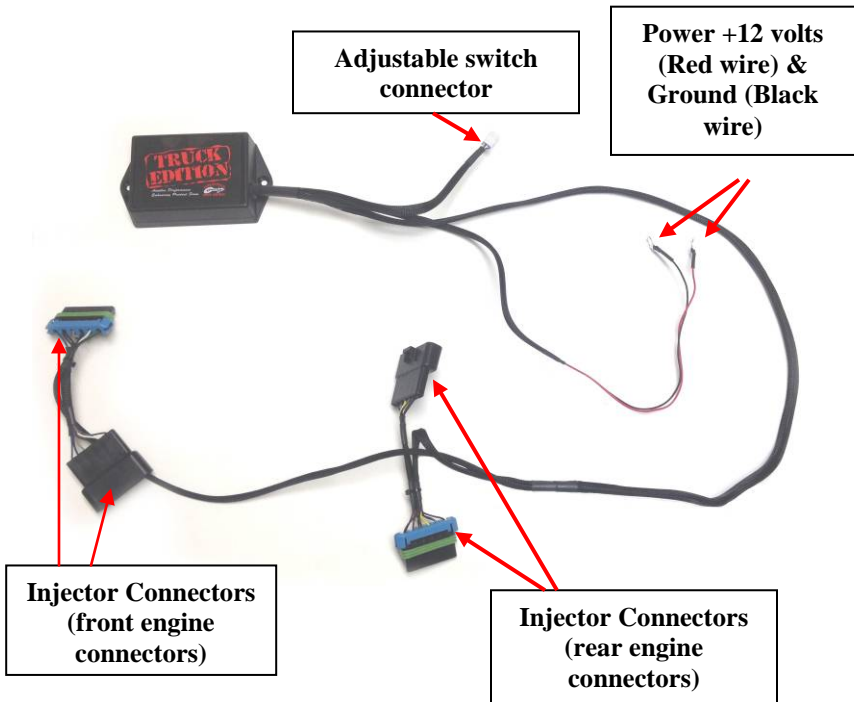

For Tech Support Please Call  
 1.812.618.9168 or 1.855.343.7680

Position 1 - Stock - 0HP Gain  
 Position 2 - Low - Up to 30HP  
 Position 3 - Med - Up to 60HP  
 Position 4 - High - Up to 90HP  
 Adjustable on the Fly  
 Position 1 - Switch to Far Left  
 Position 4 - Switch to Far Right



Module Switch can be ran inside the cab for easy performance adjustment  
 Module Switch can be secured in engine bay if desired  
 Module will default to HIGH setting if Switch is not connected

**\*NOTE: If towing over 15,000lbs, turn module from HIGH mode to MEDIUM mode\***

**\*NOTE: Do not change performance settings while vehicle under excessive load\***

**\*NOT FOR USE IN CALIFORNIA\***

**\*MODULE DOES NOT BYPASS, DELETE OR DEFEAT ANY EMISSION CONTROL SYSTEMS\***

**\*If installation assistance is needed, Ag Diesel Solutions is not responsible for any cost associated with third party instalation\***

## 6.7L Dodge Cummins Engine Instructions

- 1) Locate the 2 Injector Plugs on the driver's side of the engine. The "Front Injector Plugs" correspond to the Front side (Cooling Fan side) of the engine. The "Rear Injector Plugs" correspond to the Rear side (Transmission side) of the engine.  
**\*\*Refer to module diagram on page 2 for correct wiring.**



- 2) Disconnect the engine connector labeled below. This will allow access to the rear injector plug.  
**Note: Rotate the grey locking lever to release the plug. Once disconnected, move the plug out of the way.**

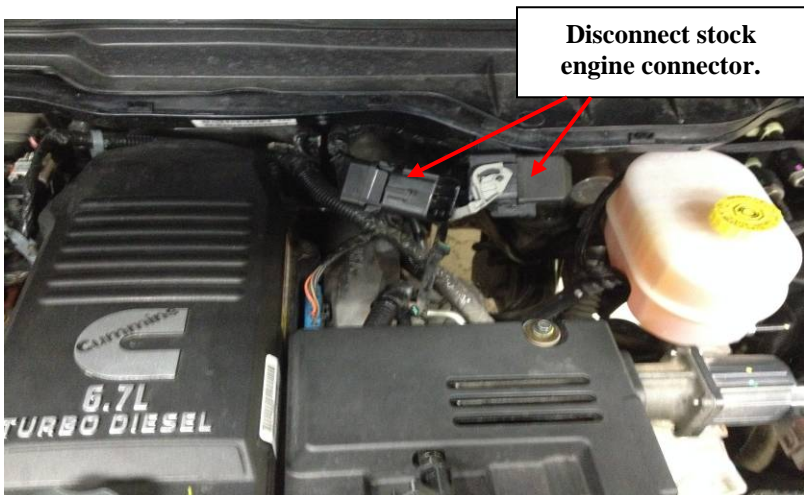

- 3) Disconnect both, the front and rear, stock male Injector Plugs on the engine.



- 4) Connect the stock male Injector Plugs, removed in Step 3, to the female plugs on the new module harness. **Do this for BOTH the Front and Rear Injector Plugs.**

*Note: The injector connector located at the end of the module harness will plug into the injector connector located closest to the front of the engine (cooling fan side).*

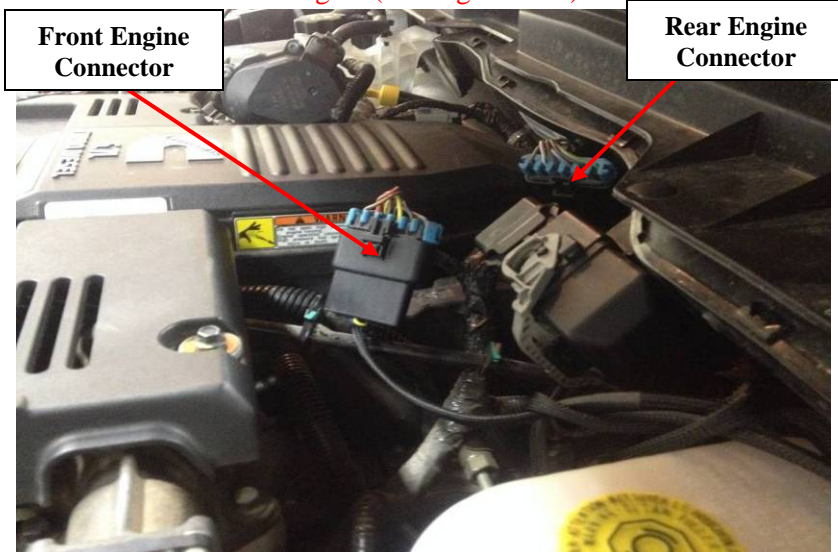

- 5) Connect both of the new module harness Injector Plugs into the Injector Connectors on the engine. **Do this for BOTH the Front and Rear Injector Plugs.**



- 6) **Reconnect the stock engine connector that was disconnected in Step 2.**
- 7) Connect the Black wire with a Ring Terminal to the Negative/Ground Battery Terminal on the driver's side engine battery. Use a 13mm socket to remove the stock battery nut.
- 8) Connect the Red wire with a Ring Terminal to the battery +12 volt constant source on the driver's side engine battery. Use a 10mm socket to remove the stock battery nut.

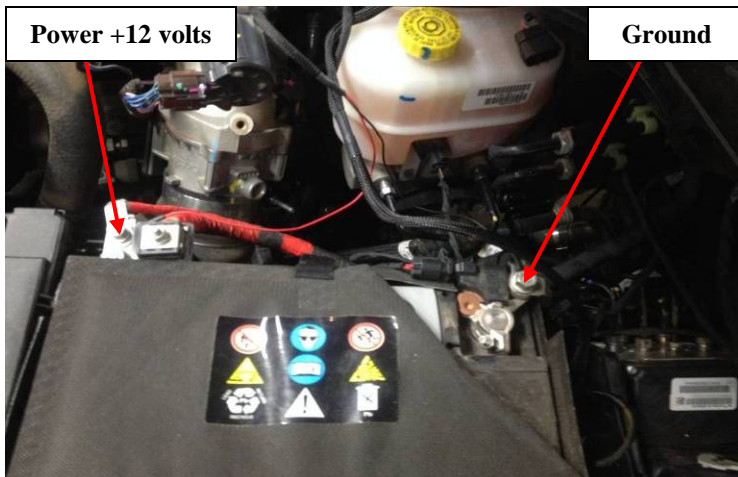

9) Mount the module box with the provided zip ties in a secure and dry location.

\* Note: Zip tying onto any factory wire harness works well or the module can be placed next to the battery.



10) The switch can be routed through the firewall or can be left in the engine compartment next to the module. Connect the switch as shown.

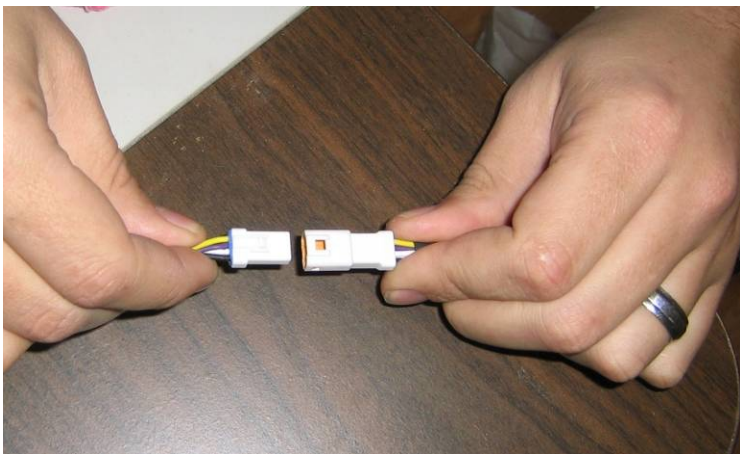

**THIS IS A HIGH PERFORMANCE PRODUCT. USE AT YOUR OWN RISK.**

Do not use this product until you have carefully read the following agreement.

This sets forth the terms and conditions for the use of this product. The installation of this product indicates that the BUYER has read and understands this agreement and accepts its terms and conditions

**DISCLAIMER OF WARRANTY AND LIMITATION OF LIABILITY**

Power Systems Innovations, Inc and its successors, distributors, jobbers, and dealers (hereafter "SELLER") shall in no way be responsible for the product's proper use and service. It is the installer's responsibility to check for proper installation and if in doubt, contact the manufacturer. The SELLER assumes no liability regarding the improper installation or misapplication of its products. BUYER ACKNOWLEDGES IT HAS HAD THE OPPORTUNITY TO FULLY INSPECT THE PRODUCT. ACCORDINGLY, BUYER ACKNOWLEDGES THAT THE PRODUCT IS BEING SOLD IN "AS IS/WHERE IS" CONDITION AND WITH ALL FAULTS. EXCEPT AS OTHERWISE PROVIDED HEREIN, THERE ARE NO EXPRESS WARRANTIES WITH RESPECT TO THE GOODS, AND ALL IMPLIED WARRANTIES, INCLUDING BUT NOT LIMITED TO, IMPLIED WARRANTIES OF FITNESS FOR A PARTICULAR PURPOSE AND MERCHANTABILITY ARE LIKewise HEREBY EXPRESSLY AND FULLY DISCLAIMED. SELLER SHALL NOT BE HELD LIABLE FOR SPECIAL, INDIRECT, INCIDENTAL OR CONSEQUENTIAL DAMAGES OF ANY NATURE WITH RESPECT TO THE PRODUCTS (INCLUDING, WITHOUT LIMITATION, LOST PROFITS, LOST SALES, LOSS OF PRODUCTION, PROPERTY DAMAGE, PERSONAL INJURY OR LOSS OR DAMAGE RESULTING FROM INTERRUPTION OR FAILURE IN OPERATION OF THE PRODUCTS) AND BUYER HEREBY EXPRESSLY WAIVES AND DISCLAIMS ALL SUCH LIABILITY CLAIMS. THE BUYER ACKNOWLEDGES AND AGREES THAT THE DISCLAIMER OF LIABILITY CONTAINED HEREIN IS A MATERIAL TERM OF THE SALE OF THE PRODUCT AND, TO THE FULLEST EXTENT PERMITTED BY LAW, BUYER SHALL DEFEND, INDEMNIFY AND HOLD SELLER HARMLESS FROM ANY AND ALL CLAIMS, DEMANDS, CAUSES OF ACTION, CONTROVERSIES, LIABILITIES, FINES, LOSSES, COSTS AND EXPENSES (INCLUDING, BUT NOT LIMITED TO ATTORNEYS' FEES, EXPERT WITNESS EXPENSES AND LITIGATION EXPENSES) ARISING FROM OR RELATED TO SELLER'S PRODUCTS.

**LIMITED LIFETIME WARRANTY**

Power Systems Innovations, Inc (hereafter "SELLER") warrants that the product supplied shall conform to SELLER's specifications and shall be free from defects in design, material or workmanship for the life of the original BUYER. This Warranty shall not be extended, transferred, assigned or varied except by a written instrument signed by SELLER and BUYER.

Products that have been returned to SELLER during the warranty period and accompanied by a dated proof of purchase receipt, with shipping and handling paid by the BUYER, and found to be defective in design, material or workmanship, in SELLER's sole discretion, may be repaired or replaced at SELLER's option and cost. All warranty claims hereunder are subject to approval by SELLER upon examination of the product. If the product is found not to be defective by SELLER, the product may be returned to BUYER at BUYERS cost. Under no circumstances shall the SELLER be liable for any labor charged or travel time incurred in diagnosis for defects, removal, or reinstallation of this product, or any other expenses. This warranty is void on any products that show evidence of misapplication, negligence, improper installation, abuse, lack of proper maintenance or alteration from its original design.

IN THE EVENT THAT THE BUYER DOES NOT AGREE WITH THIS AGREEMENT: THE BUYER MAY PROMPTLY RETURN THIS PRODUCT, IN A NEW AND UNUSED CONDITION, WITH A DATED PROOF OF PURCHASE, TO THE PLACE OF PURCHASE WITHIN THIRTY (30) DAYS FROM DATE OF PURCHASE FOR A FULL REFUND. THE INSTALLATION OF THIS PRODUCT INDICATES THAT THE BUYER HAS READ AND UNDERSTANDS THIS AGREEMENT AND ACCEPTS ITS TERMS AND CONDITIONS.

# AGRICULTURE



Up to 30% Horsepower Increase  
10-20% Fuel Savings  
Does NOT Flash Factory ECM  
Does NOT Void Equipment Warranty  
Plug and Play Installation  
LIFETIME WARRANTY

# CONSTRUCTION



Up to 30% Horsepower Increase  
10-20% Fuel Savings  
Does NOT Flash Factory ECM  
Does NOT Void Equipment Warranty  
Plug and Play Installation  
LIFETIME WARRANTY

# TRUCK EDITION: LIGHT DUTY



Up to 90 Horsepower Increase  
1-3 MPG Fuel Savings  
Does NOT Flash Truck ECM  
Does NOT Void Factory Warranty  
Plug and Play Installation  
LIFETIME WARRANTY

# TRUCK EDITION: MED, HEAVY DUTY



Up to 30% Horsepower Increase  
5-15% Fuel Savings  
Does NOT Flash Truck ECM  
Does NOT Void Factory Warranty  
Plug and Play Installation  
LIFETIME WARRANTY

LEARN MORE: [AGDIESELSOLUTIONS.COM](http://AGDIESELSOLUTIONS.COM)

