

# METAL CASE SWITCHBOARD METERS

AC Ammeter

Self Contained



0-1 AC Amperes Input: 1.0 AAC

Catalog #: **TMCS 103131LALA**

Ordering #: 1D2012

## Features:

- Designed For Commercial and industrial use
- Steel case with integrated mounting studs and poly-carbonate cover
- IP54 Sealed case maintains accuracy and prolongs meter life
- Easy to read at any distance or angle
- Clean, clear, easy-to-read dials
- Metal housing shields mechanisms against magnetic fields

## Mounting & Dimensions

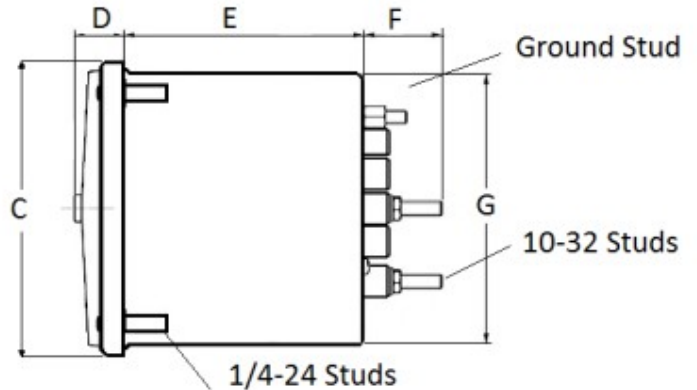
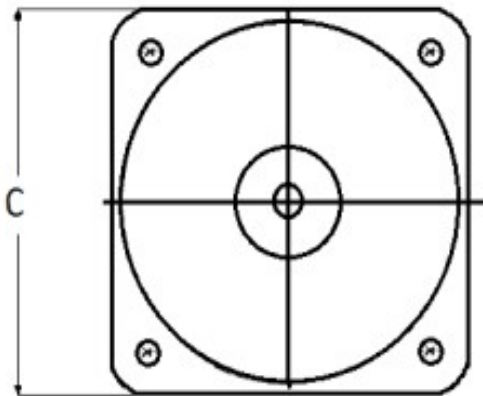

## Wiring Diagram

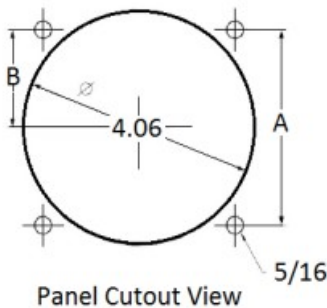

	INCHES
A	3.37"
B	1.69"
C	4.30"
D	0.65"
E	2.65"
F	0.98"
G	3.95"

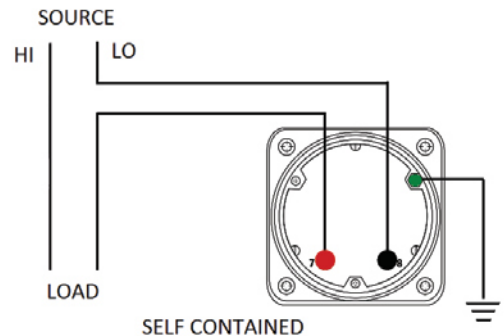

(800) 766-1212



shop.byramlabs.com

Byram Laboratories, Inc. 1 Columbia Rd. Branchburg, NJ 08876

© 2021 by Byram Laboratories, Inc. All rights reserved.