

METAL CASE SWITCHBOARD METERS

DC Ammeter

Use with 50mV shunts and 0.05 Ohm shunt leads (standard 5-foot leads)



0-500 DC Amperes Rating: 50 millivolts

Catalog #: MCS 103121CASF

Ordering #: 1D0029

Features:

- Designed For Commercial and industrial use
- Steel case with integrated mounting studs and poly-carbonate cover
- IP54 Sealed case maintains accuracy and prolongs meter life
- Easy to read at any distance or angle
- Clean, clear, easy-to-read dials
- Metal housing shields mechanisms against magnetic fields

Mounting & Dimensions



Wiring Diagram

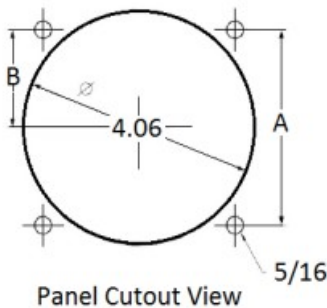

	MCS
	INCHES
A	3.37"
B	1.69"
C	4.30"
D	0.65"
E	2.25"
F	0.98"
G	3.95"

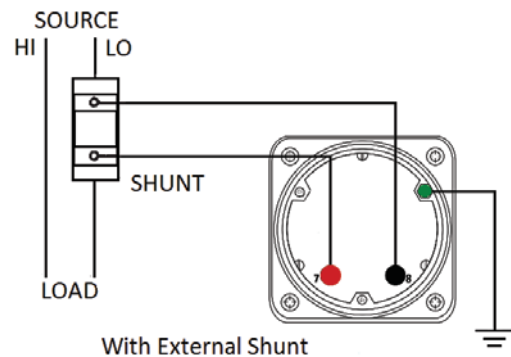

(800) 766-1212



shop.byramlabs.com

Byram Laboratories, Inc. 1 Columbia Rd. Branchburg, NJ 08876

© 2021 by Byram Laboratories, Inc. All rights reserved.