

# METAL CASE SWITCHBOARD METERS

DC microammeter

Self Contained



0-500 DC Microamperes

Catalog #: **MCS 103111EMEM**

Ordering #: 1C9990

## Features:

- Designed For Commercial and industrial use
- Steel case with integrated mounting studs and poly-carbonate cover
- IP54 Sealed case maintains accuracy and prolongs meter life
- Easy to read at any distance or angle
- Clean, clear, easy-to-read dials
- Metal housing shields mechanisms against magnetic fields

## Mounting & Dimensions

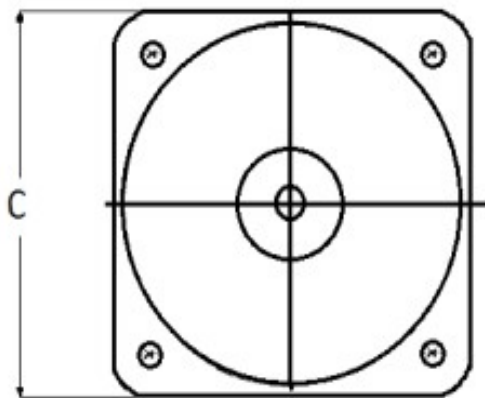

## Wiring Diagram

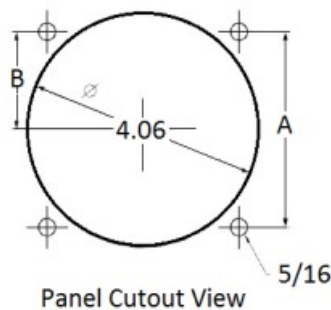

	MCS
	INCHES
A	3.37"
B	1.69"
C	4.30"
D	0.65"
E	2.25"
F	0.98"
G	3.95"

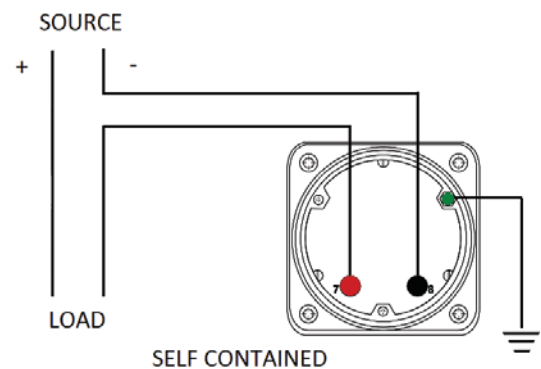

(800) 766-1212



shop.byramlabs.com

Byram Laboratories, Inc. 1 Columbia Rd. Branchburg, NJ 08876

© 2021 by Byram Laboratories, Inc. All rights reserved.