



Vericom® Double Hinge Swing Out Wall Mount Cabinets are a great solution for networking, security, and AV installations where access to the back of the equipment is important. Compatible with all standard 19-inch EIA equipment, these cabinets feature a swing-out design that also allows the rear section to completely disconnect from the cabinet, making installation a breeze.

Constructed of cold rolled, powder-coated 19-gauge steel, these swing out wall mount cabinets have a maximum load capacity of 100 pounds and are available in 9U, 12U, and 15U racking heights. Ships unassembled and flat packed for easy on-site handling.

Benefits

Security & Protection

- Locking front and rear doors prevent unauthorized access to equipment
- Two sets of rails provide a stable mounting structure
- Doors are grounded to the cabinet frame

Flexibility

- Multiple cable entry options provide greater flexibility during installation
- Mounting rails are adjustable to match a variety of equipment sizes
- Doors are removable for convenient access to equipment

Multi-Use

- Available in three sizes to fit in a variety of environments where space is limited
- Top and bottom panel vents to optimize cooling of equipment
- Adaptable for use in network, security and audio/visual installations

Key Features

- Cable entry on top, bottom and back
- Lace points to reduce cable clutter
- Lockable acrylic front door is removable and reversible
- Removable rear door swings out from wall 90° for accessibility



Rear door swings out from wall 90° from either left or right corner

Vents in top panel for mounting optional fans



Removable 12 x 12 panel in rear door for easy cabinet access

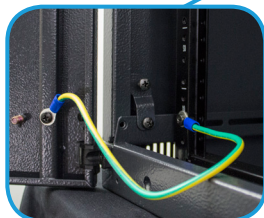

Front and rear doors equipped with ground wires



Mounting rails, complete with 10-32 tapped holes and easy to read RU markings



Removable, reversible & lockable steel front door equipped with full panel acrylic window

Product Dimensions

Item Number	Product Dimensions (H x W x D)	Rack Unit Quantity	Max. Usable Depth	Static Load Capacity
RWCDH09	18.11" x 21.25" x 23.62"	9U	20.5"	100 lbs.
RWCDH12	23.43" x 21.25" x 23.62"	12U	20.5"	100 lbs.
RWCDH15	28.54" x 21.25" x 23.62"	15U	20.5"	100 lbs.

Optional Accessories

Item Number	Product Description	Item Compatibility
RAMS4D1	Horizontal D-Ring Cable Manager (4 rings, steel), 1U	RWCDH09, RWCDH12, RWCDH15
RAFND02	Double Fan, 150 CFM	RWCDH09, RWCDH12, RWCDH15
RASC122	12" Cantilever Shelf, 2U	RWCDH09, RWCDH12, RWCDH15
RASA231	Adjustable Depth Wall Cabinet Shelf, 1U	RWCDH09, RWCDH12, RWCDH15
RAMSFD1	Horizontal Finger Duct Cable Manager (Steel), 1U	RWCSF09, RWCSF12, RWCSF15

Additional accessories available. For a complete list visit vericomsolutions.com

Technical Illustration

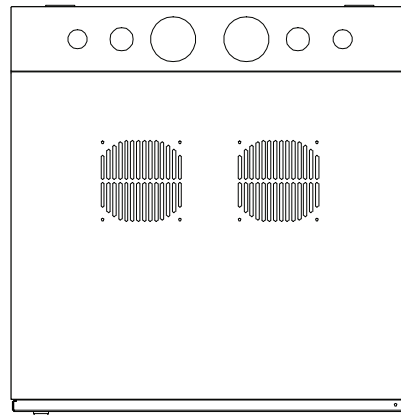

TOP

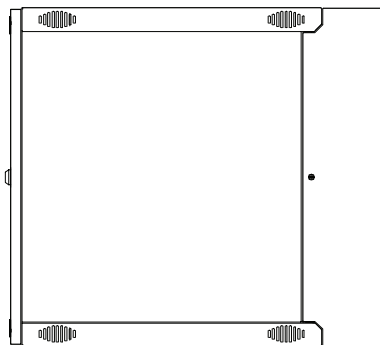

SIDE

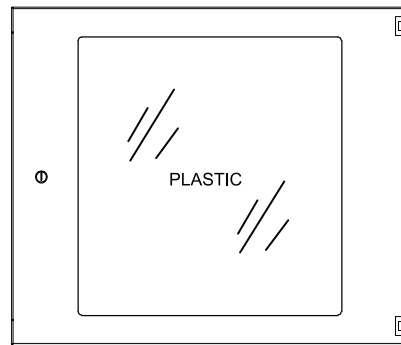

FRONT

Specifications

Front Door	Removable, Reversible & Lockable Steel Frame with Full Panel Acrylic Window, Opens Full 180°
Back Door	Swings Out From Wall 90° From Either Left Or Right Corner 12" x 12" Removable Panel Wall Mounting Keyholes Spaced 16" Apart Multiple Lace Points
Side Panels	Solid, Built into Frame
Top Panel	Ventilation Holes for Optional Fans (6) Knock-Out Cable Entry Holes Located at Back: (2) ¾", (2) 1" and (2) 2" Knockouts
Bottom Panel	Ventilation Holes (6) Knock-Out Cable Entry Holes Located at Back: (2) ¾", (2) 1" and (2) 2" Knockouts
Equipment Support	Two Pairs of Mounting Rails Adjustable Depth Rails (3" Range) 1.75" RU Spacing, Marked and Numbered on Rails 19" W, EIA-310-D Universal Hole Spacing 10-32 Threaded Holes
Grounding	14 AWG Ground Wire Connects Doors to Cabinet Frame
Finish	Black Powder Coat
Static Loading Capacity	100 lbs.
Included Accessories	(2) Grounding Kit (48) 10-32 Mounting Screws & Washers (1) Paper Mounting Template (2) Keys
Compliance	ANSI/EIA RS-310D IEC60297-2 DIN41494; Part 1 DIN41494; Part 7

