



COMMERCIAL RICE COOKER & WARMER NYC-36

OPERATING INSTRUCTIONS

Always follow basic safety precautions when using electrical appliances.
Read all instructions carefully. Please keep this instruction book handy for
easy reference.



INDEX

IMPORTANT SAFEGUARDS.....	1~5	CLEANING.....	10
PARTS NAMES AND FUNCTIONS.....	6	TROUBLE SHOOTING GUIDE.....	11
HOW TO COOK RICE.....	7~9	SPECIFICATIONS.....	11
TIPS FOR COOKING TASTY RICE AND KEEPING WARM.....	9		

ZOJIRUSHI CORPORATION
OSAKA, JAPAN

IMPORTANT SAFEGUARDS

WHEN USING ELECTRICAL APPLIANCES, BASIC SAFETY PRECAUTIONS SHOULD ALWAYS BE FOLLOWED, INCLUDING THE FOLLOWING:

- 1** Read all instructions carefully.
- 2** Do not touch hot surface. Use handles or knobs. Do not close or clog the steam vent opening under any circumstance.
- 3** To prevent electrical shock hazards, do not immerse cord, plugs, or rice cooker, except inner lid and inside pan, in water or any other liquid.
- 4** Close supervision is necessary when the appliance is used by or near children.
- 5** Unplug the power supply cord when neither the cooker nor warmer is in use, or before cleaning. Allow to cool before putting on or taking off any parts, and before cleaning the appliance. Make sure appliance is OFF when not in use, before putting on or taking off parts, and before cleaning.
- 6** Do not use or operate the appliance with a damaged cord or plug, or after the appliance has been damaged in any manner. Return the appliance to the nearest authorized service facility or dealer for examination, repair, or adjustment.
- 7** The use of accessories not recommended by the appliance manufacturer may cause hazards.
- 8** Do not use outdoors.
- 9** Do not let the power supply cord hang over the edge of a table or counters, or touch hot surfaces.
- 10** Do not place the appliance on or near heat sources such as gas or electric stoves, ovens, or burners.
- 11** Extreme caution must be given when moving the appliance containing hot contents or liquids.
- 12** To disconnect, turn control to "KEEP WARM" then remove plug from an electric outlet.
- 13** Do not use the appliance for other than intended or specified purposes.
- 14** To reduce the risk of electrical shock, cook only in removable container.

SAVE THESE INSTRUCTIONS

This appliance is supplied with a short cord to reduce the risk of becoming entangled or tripping. Extension cords are available and may be used if care is exercised in their use. If extension cord is used, the marked electrical rating of the cord set should be at least as great as the electrical rating of the appliance, and the longer cord should be arranged so that it will not drape over the countertop or tabletop where it can be pulled on by children or tripped over unintentionally.

IMPORTANTES MESURES DE SÉCURITÉ

POUR UTILISER DES APPAREILS ÉLECTRIQUES, IL FAUDRAIT TOUJOURS PRENDRE LES PRÉCAUTIONS DE BASE, Y COMPRIS LES SUIVANTES.

- 1** Lisez toutes les instructions.
- 2** Ne touchez pas les surfaces qui peuvent être chaudes. Utilisez les poignées ou les boutons.
- 3** Pour éviter les chocs électriques, ne plongez pas le cordon, la fiche ou l'appareil portatif dans l'eau ou un autre liquide.
- 4** Surveillez bien les enfants s'ils utilisent un appareil ou s'ils se trouvent à proximité d'un appareil en marche.
- 5** Débranchez l'appareil de la prise de courant quand vous ne l'utilisez pas avant d'enlever ou d'installer des pièces et avant de le nettoyer. Laissez l'appareil refroidir avant de le manipuler. Assurez-vous que l'appareil est ARRÊTÉ quand vous ne l'utilisez pas avant d'enlever ou d'installer des pièces et avant de le nettoyer.
- 6** Appareils portatifs. Ne faites pas fonctionner l'appareil si le cordon ou la fiche sont endommagés, si l'appareil ne fonctionne pas correctement, s'il est tombé ou s'il a été endommagé. Confiez au service de réparation recommandé le plus proche tout examen, réparation ou réglage électrique ou mécanique de l'appareil.
- 7** L'utilisation d'accessoires non recommandés par le fabricant de l'appareil peut causer des blessures.
- 8** N'utilisez pas l'appareil à l'extérieur.
- 9** Ne laissez pas le cordon pendre par-dessus le bord d'une table ou d'un comptoir et assurez-vous que le cordon n'est pas en contact avec des surfaces chaudes.
- 10** Ne placez pas l'appareil près d'un brûleur à gaz allumé ou d'un élément électrique ou tension ou dans un four allumé.
- 11** Soyez très prudent en déplaçant un appareil qui contient des matières chaudes ou du liquide chaud.
- 12** Avant de débrancher, placez l'interrupteur sur la position "CONSERVATION DE LA CHALEUR" puis retirez la fiche de la prise de courant.
- 13** N'utilisez l'appareil que pour la fonction à laquelle il est destiné.
- 14** Pour réduire les risques de choc électrique, ne cuire que dans le récipient amovible.

CONSERVEZ CES INSTRUCTIONS



L'appareil est livré avec un cordon court afin de réduire les risques d'emmêlements ou de chutes. Des rallonges électriques sont disponibles et peuvent être utilisées en respectant les précautions nécessaires. En cas d'utilisation, la tension du courant indiquée sur la rallonge électrique devra au minimum être égale à celle de l'appareil et la longueur du cordon sera réglée de manière à ce qu'il ne pende pas de la table ou du comptoir où il est posé afin d'éviter les accidents d'emmêlement dans le cordon ou tout accident provoqué par des enfants qui tireraient dessus.

IMPORTANT SAFEGUARDS (Cont.)







Before use

※ These WARNINGS and CAUTIONS are intended to protect you and other persons from injuries and damages.

To ensure safe operation, please follow them carefully.







	WARNINGS	Indicates risk of serious injury.
	CAUTIONS	Indicates risk of injury or property damage if mishandled.

About the symbols

<p> Indicates a warning or caution. The symbol inside the triangle specifies the nature of the warning or caution. The example below indicates an electrical shock warning.</p> 	<p> Indicates a prohibition. The symbol inside the circle specifies the nature of the prohibition. The example below indicates "Do not disassemble".</p> 	<p> Indicates a requirement or instruction that must be followed. The symbol inside the circle specifies the nature of the requirement or instruction. The example below left indicates unplug the unit; the example below right indicates that the accompanying instruction must be followed.</p>  
----------------------------------------------------------------------------------------------------------------------------------------------------------------------------------------------------------------------------------------------------------------------------------------------------------------------------------------------------	-----------------------------------------------------------------------------------------------------------------------------------------------------------------------------------------------------------------------------------------------------------------------------------------------------------------------------	---------------------------------------------------------------------------------------------------------------------------------------------------------------------------------------------------------------------------------------------------------------------------------------------------------------------------------------------------------------------------------------------------------------------------------------------------------------------------------------------------------------------------------------------------------------

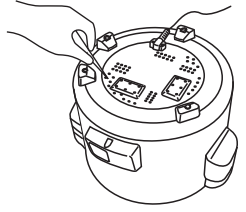
※ Please keep the Operating Instructions for future reference.

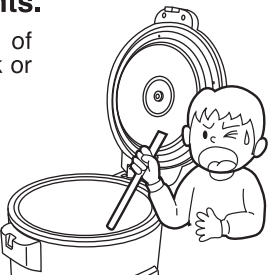
! WARNINGS

<p>■ Do not modify the Rice Cooker. Only a repair technician may disassemble or repair this unit.</p> <p>Attempting to do so may cause fire, electrical shock, or injury. Make any repair inquiries to ZOJIRUSHI Customer Service.</p>  	<p>■ Do not drop any metal objects such as pins or wires into the bottom holes of the Rice Cooker.</p> <p>Doing so may cause an electrical shock or malfunction, resulting in injury.</p>  
<p>■ Do not allow children to use this product unsupervised. Keep it out of the reach of infants.</p> <p>Children are at risk of burns, electrical shock or injury.</p>  	<p>■ Do not open the Outer Lid or move the Rice Cooker while it is cooking.</p> <p>It may cause burns.</p>  

※ Please keep the Operating Instructions for future reference.

IMPORTANT SAFEGUARDS (Cont.)

⚠️ WARNINGS

- **If the blades or surface of the Power Plug are soiled, wipe them clean.**

A dirty Power Plug may cause a fire.

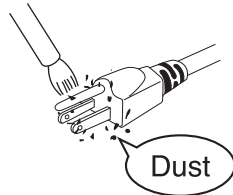

- **Use only an electrical outlet rated at 15 amperes minimum. Do not plug other devices into the same outlet.**

Plugging other devices into the same outlet may cause the electrical outlet to overheat, resulting in fire.

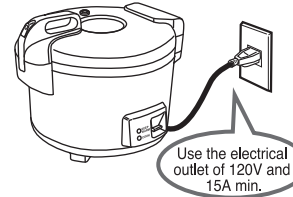

- **Do not immerse the Rice Cooker in water or splash it with water. Do not pour water directly into the Rice Cooker.**

Doing so may cause a short-circuit or electrical shock.



- **Do not use the Rice Cooker if the Power Plug or Power Cord is damaged or plug is loosely inserted into the electrical outlet.**

Doing so may cause an electrical shock, short circuit or fire.

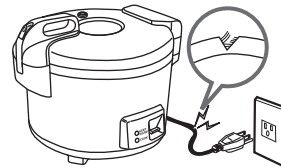

- **Do not damage the Power Cord.**

Do not forcefully bend, pull, twist, fold, bring it near high temperature objects, place heavy items, sandwich it between other objects or modify it. A damaged Power Cord can cause a fire or electrical shock.



- **Do not use a power source other than 120V AC.**

Use of any other power supply voltage may cause a fire or electrical shock.

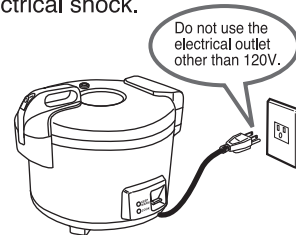

- **Insert the Power Plug securely.**

Otherwise it may cause an electrical shock, short-circuit, smoke or fire.



- **Do not plug or unplug the Power Plug with a wet hand.**

Doing so may cause an electrical shock or injury.

- **Do not touch the Steam Vent.**

Doing so may cause burns or scalding. Take special precautions with children and infants.



IMPORTANT SAFEGUARDS (Cont.)

⚠ CAUTIONS



- **Do not use the Rice Cooker where it may be splashed by water or near heat sources.**

Doing so may cause an electrical shock, short-circuit, or deformation of the Rice Cooker.



- **Unplug the Power Plug from the outlet when the Rice Cooker is not in use.**

Leaving the Power Plug in an outlet may cause the insulation to become damaged, resulting in an electrical shock, short-circuit or fire.



- **Do not place or use the Rice Cooker on unstable surfaces or on surfaces that are vulnerable to heat.**

Doing so may cause fire.



- **Please allow the Rice Cooker to cool down before cleaning.**

Touching hot parts may cause burns.



- **Do not touch hot parts during or immediately after use.**

Be careful of steam when opening the Outer Lid. Be careful not to touch the Inner Pan when loosening rice.



- **Do not use the Rice Cooker near a wall or furniture. Make sure that steam does not collect under shelving.**

Steam or heat may damage, discolor or deform the wall or furniture.



- **Do not use other than the specified Inner Pan.**

Doing so may cause the Inner Pan to overheat and may cause the Rice Cooker to malfunction.



- **Be sure to hold the Power Plug when unplugging the Power Cord. Do not unplug pulling the Power Cord.**

Pulling the Power Cord to unplug may cause an electrical shock, short-circuit or fire.



- **Do not touch the Hook Button or give a strong impact while moving the product.**

Doing so may cause the Lid to open, resulting in an injury or burn.

IMPORTANT

- **Do not use of the Inner Pan or Heating Plate with foreign matters adhered to it. Remove foreign matters before use.**

It may cause imperfect cooking.

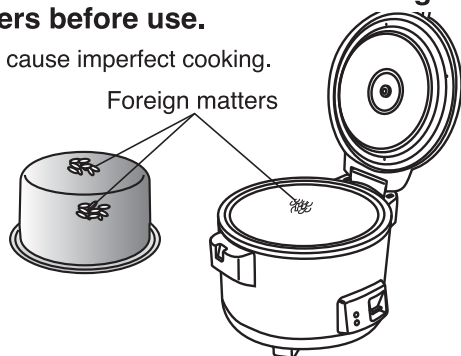

- **Do not cover the Steam Vent with a cloth or other objects.**

Doing so may cause deformation and/or discoloration.

PARTS NAMES AND FUNCTIONS

How to open the Outer Lid.

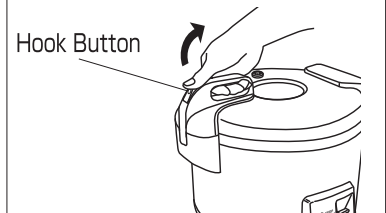

Hook Button

Press down the Hook Button and lift the lid upward.

How to attach or remove the Inner Lid.

To attach:

- Insert the Inner Lid Gasket to the Inner Lid Supporting Pin.



To remove:

- Hold the Outer Lid first, then pull the Inner Lid toward you to release.

How to attach or remove the Dew Collector.

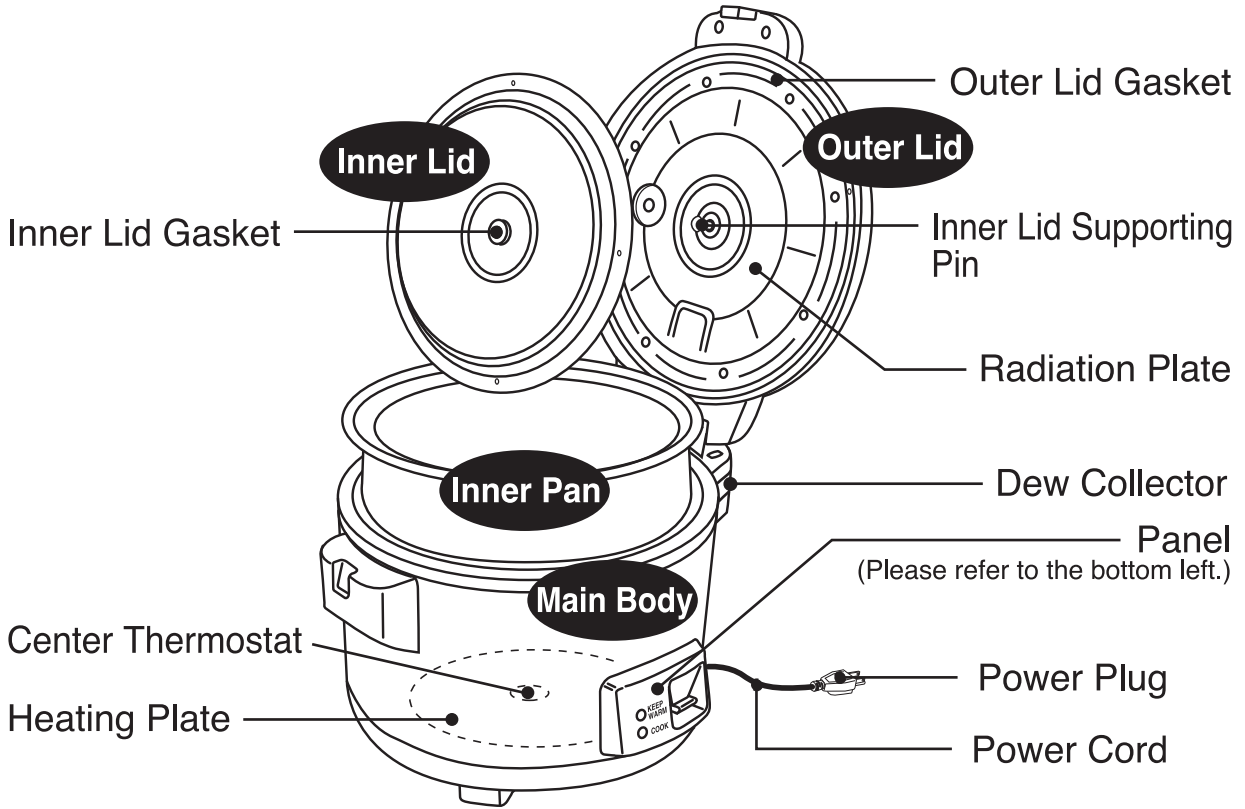
Panel

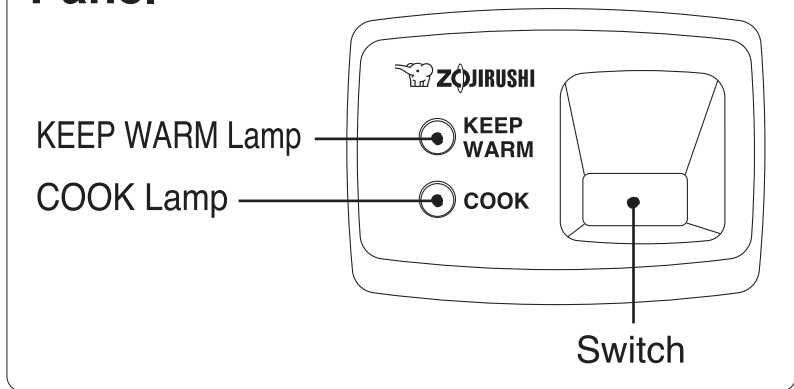

KEEP WARM Lamp

KEEP WARM

COOK Lamp

COOK

Switch

Attachments

Spatula



Measuring Cup

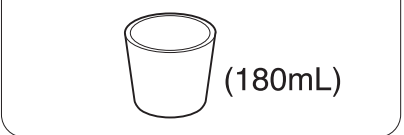

(180mL)

HOW TO COOK RICE

1 Measure the Rice accurately.

Measure the rice using the Measuring Cup provided and level it off.

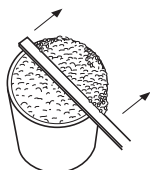

- Using anything other than the provided measuring cup to measure rice may produce slight variations in the finished cooked rice.
- If the rice measurement is not accurate, cooked rice may not have a desired texture of rice.

What is Rinse-Free rice (Musenmai) ?

Rinse-Free rice (Musenmai) is a new type of rice that does not require washing. Ordinary polishing can not completely polish away bran and residues from the rice surface. For this reason, it is recommended to wash the rice before cooking. However recently, a new milling technology has been developed in Japan. This process eliminates the bran and residues from the rice without sacrificing the quality.

2 How to cook White rice Wash the rice in a separate container, then place the rice into the Inner Pan.

- If you wash the rice in the Inner Pan, the bottom may dent or get damaged and you may not be able to cook the rice well.
- Do not use hot water to wash or cook rice.

How to cook Rinse-Free rice

Put the rice and water in the Inner Pan, and stir gently a few times.

- Stirring the rice and water after it is in the Inner Pan allows each grain of rice to mix with water. The water becomes white when stirring due to the rice starch, and not from rice bran. If it appears too thick, change the water and rinse the rice for a few times. Cooking the rice in thick white water may cause rice to scorch.
- Adjusting the water without stirring may cause the finished rice to get hard or cause scorching.
- Do not use hot water to wash or cook rice.

3 Adjust the amount of water.

Adjust the amount of water by referring to the water level scales for "WHITE RICE" or "RINSE-FREE RICE".

(Example) When cooking 10 cups of White rice

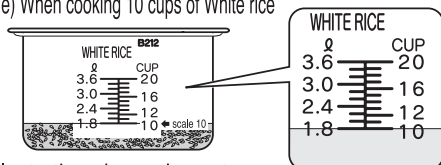

※ This illustration shows the water level scales for "WHITE RICE".

Example: When you cook 10 cups of White rice, add water into the Inner Pan up to the scale 10 of "WHITE RICE".

※ For cooking 10 cups of Rinse-Free rice, add water into the Inner Pan up to the scale 10 of "RINSE-FREE RICE".

- Place the Inner Pan on a level surface for accurate measurement.
- Soak the rice for about 30 minutes during the summer and more than two hours during the winter time.

Soaking Rinse-Free rice

※ Water temperature rises in the summer time.

Rinse-Free rice may degenerate quicker when soaked in water at a temperature more than 77°F(25°C). In this case, wash the rice well and switch on the Rice Cooker immediately.

4 Place the Inner Pan in the Main Body and close the Outer Lid.

Wipe off water or foreign matters on the outside of the Inner Pan as well as the inside of the Main Body, and securely place the Inner Pan on the heating plate.



Close the Outer Lid gently and securely.

- Make sure to wipe off water or foreign matters on the outside of the Inner Pan as well as the surface of the Heating Plate. Not doing so may cause corrosion as well as noise during cooking, preventing the rice from cooking properly.

5 Insert the Power Cord to the electrical outlet, then press down the Switch.

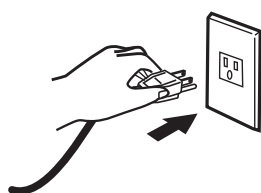

The Keep Warm Lamp will turn on when the Power Cord is inserted to the outlet.

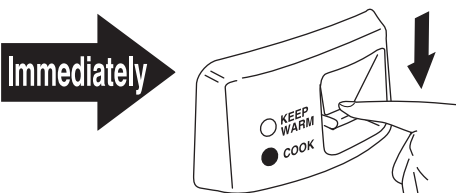

Press down the Switch, then the Cook Lamp will turn on.

- Be sure to press down the Switch immediately after setting the Inner Pan into the Rice Cooker. Leaving the rice cooker plugged in without pressing the Switch may result in improper cooking.

6 When the cooking process turns to Keep Warm, allow the rice to steam for about 15 minutes.

When the cooking process turns to Keep Warm, the Keep Warm Lamp will turn on.



Even after the lamp turns to Keep Warm, do not open the Outer Lid but leave the rice for about 15 minutes allowing the rice to steam. This is the tips to cook tasty rice.

Standard rice cooking times

Minimum cooking quantity : 10 Cups	Maximum cooking quantity : 20 Cups
Approx. 21 minutes	Approx. 30 minutes

※The above times do not include the steaming time of about 15 minutes.

●The above table is based on 120 Voltage, water at a starting temperature of 64°F, and at a room temperature of 68°F.)

- The time depends on the voltage, room temperature, season and amount of water.

7 Stir and loosen the rice.

Please remember to throw away the residue in the Dew Collector.



Stir and loosen the rice from the bottom to the surface with the Spatula provided.

- Please remember to clean the Dew Collector every time after you cook the rice otherwise it may cause odors.
- Please gather the rice adhered to the Inner Pan toward the center to avoid it from drying.

Scorched Rice

- By cooking conditions, the rice on the bottom of the Inner Pan may become slightly browned or scorched.

8 Keep Warm (Do not keep rice warm for more than 12 hours)

Level the surface of the rice before starting the Keep Warm function.

Please refer to the “TIPS FOR HOW TO COOK TASTY RICE AND KEEP WARM” when using the Keep Warm function for small amount of rice.

9 After Use

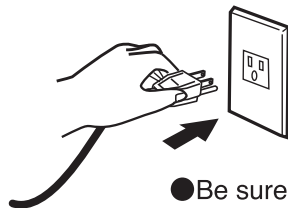

Hold the plug to unplug.

● Be sure that the Keep Warm Lamp is off.

TIPS FOR COOKING TASTY RICE AND KEEPING WARM

■ Tips for Cooking Tasty Rice

Tips for Rinsing the White rice

- The first wash should be done quickly with plenty of water, disposing of the water immediately afterwards. Then change the water and wash the rice 4 ~ 5 times to clean out the bran.

Alkaline Ionic Water

- Rice washed in water with a high alkaline content may seem yellow or glutinous when cooked.

Water adjustment

- Adjust the amount of water according to the type of rice you are going to use.

Type of rice	Water measurement
Softer White rice with germ	Normal scale level
New crop	Decrease the scale level
Old crop Harder	Increase from the scale level

- Be sure the amount of water is adjusted to the type of rice you cook.

■ Tips for keeping Warm Function

When Moving the Rice Cooker

- Be sure to plug in to have the Keep Warm mode when the Rice Cooker is unplugged for moving. (As the inside temperature drop, cause odors and the rice may become sticky.)

Be sure to close the Outer Lid securely.

- Otherwise it may cause the drying of rice, discoloring and odors.

- When keeping warm a small amount of rice, to prevent rice from drying, gather the rice toward the center of the Inner Pan.

- Do not use the Keep Warm Mode in the following cases:
Doing so may cause bad odors, drying out or discoloring.
 - ※ Do not keep rice warm for more than 12 hours.
 - ※ Do not keep rice which has already been cooled or add cold rice to warm rice.
 - ※ Do not keep food except White rice and Rinse-Free rice warm.
 - ※ Do not leave a Spatula in the Inner Pan during Keep Warm.

CLEANING Cleaning Each Part

Unplug the Rice cooker from the outlet and allow the unit to cool down before cleaning.

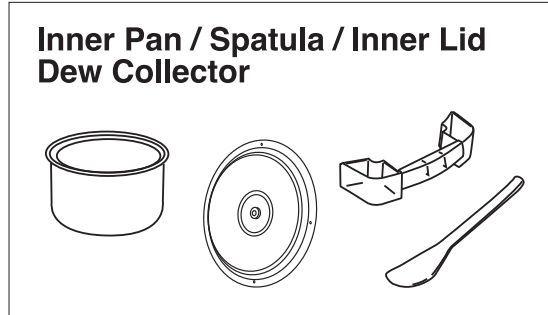

Soak in warm or cold water, and wash with a sponge.

- ※ The top portion of the Inner Pan may rust if soaked in water too long.
- ※ Please do not remove the Inner Lid Gasket when cleaning. If it comes off, please re-install by the following methods:

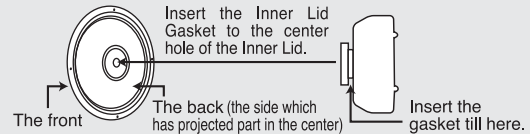

Wipe with a dry and soft cloth.

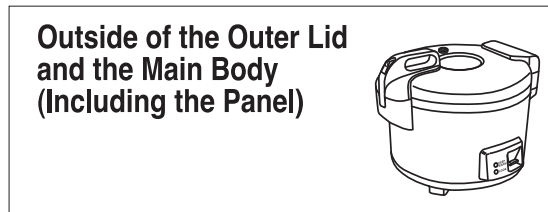

Wipe with a cloth soaked in a liquid detergent and wrung well. But wipe the control panel clean with a dry and soft cloth.

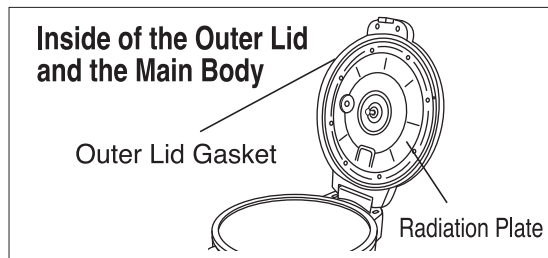

Wipe with a well-wrung damp cloth. (Wipe off any residue on the Radiation Plate with holding the Outer Lid.)

- ※ The Outer Lid Gasket can not be removed.

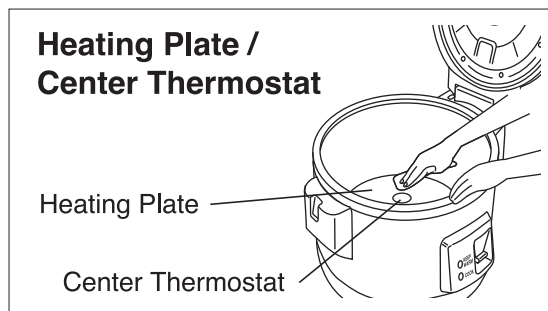

Wipe with the cloth soaked in lukewarm water and wrung well. (If grains of rice or any objects are stuck to the Heating Plate, lightly polish them off with sand paper (of about #320) dipped in water. Then wipe with a damp cloth.) Remove grains of rice or any foreign matters with a bamboo spatula or chopstick.

NOTES

- Do not clean with thinner, benzene, bleach, abrasive cleansers or anything that may damage the surface of the unit.
- When using a chemically treated cloth, do not scrub the unit strongly or allow the cloth to contact the unit for a long period of time.
- Do not use sandpaper on anything other than the Heating Plate.

Nonstick Inner Pan: The Inner Pan is coated with a nonstick surface for easy cleaning. To protect the nonstick surface, avoid the following:

- Do not use the Inner Pan for dish washing.**
- Do not use vinegar in it.**
- Clean the Inner Pan immediately after using any seasonings.**
- Do not use brushes or abrasive cleansers to clean.**

- Nonstick coating may discolor after long use. This will not affect the nonstick quality or sanitary properties.
- Contact our authorized service center or ZOJIRUSHI customer service when the Inner Pan or the Inner Lid is deformed or corroded.

TROUBLE SHOOTING GUIDE

If the results of cooking are not satisfactory, please check the following points before calling for service.

Cause (Points to check) Problems	Rice and water were not measured correctly.	Cooked rice was not stirred and loosened.	Any foreign matters are on the Heating Plate, Center Thermostat or outside of the Inner Pan.	The Inner Pan or Inner Lid are deformed.	Rice was not washed thoroughly before cooking (except for Rinse-Free rice).	The Outer Lid was not closed firmly during cooking.	Rice was kept warm for more than 12 hours (under the Regular Keep Warm process) or a small amount of rice was kept warm.	Cold rice was reheated or a Spatula left in the Inner Pan during keep warm.	The unit was unplugged during cooking.	Was the Inner Pan or Inner Lid cleaned thoroughly?	The Inner Lid was not set when cooked.
Rice is too - hard.	●	●	●	●		●				●	●
Rice is half - cooked (remaining hard).	●		●	●		●		●		●	●
Rice is too soft.	●	●	●	●						●	
Rice is scorched too much.	●		●	●	●					●	
Boiling over while cooking.	●		●	●	●	●				●	●
During Keep Warm, rice has an unusual odor, rice is discoloring, rice is too dry or much dew on rice.		●	●	●	●	●	●	●	●	●	●

In these cases, please purchase and replace Inner Pan or Inner Lid. Please contact the ZOJIRUSHI Customer Service. (Please refer to the bottom for contact number)

The Switch can not be pressed down or immediately turned off.

- Was the Inner Pan correctly placed?
- This may happen when the Inner Pan is still hot such as immediately after completion of cooking.

The unit does not work.

- Is the plug inserted properly?

- If you have any questions, please call Zojirushi Customer Service or visit our website.

ZOJIRUSHI AMERICA CORPORATION

Tel : 800-733-6270

www.zojirushi.com

SPECIFICATIONS

Model No.	NYC-36
Cooking Capacity (cups)	1.8~3.6L (10~20)
Rating	120V 1300W
Average Power Consumption during Keep Warm	52W
Rice Cooking System	Direct Heating
Power Cord	Length:1.4m
External Dimensions (inches) W×D×H	Approx.17.3×15.2×13.4
Weight	Approx.18.3lbs.

- The average power consumption during the Keep Warm mode is the value of the maximum rice cooking capacity at a room temperature of 68°F.
- As this Rice Cooker may not operate properly at certain places such as, high elevation areas and severely cold areas, please avoid using this unit Rice Cooker in such areas.
- The external dimensions are indicated by wide × depth × height.