

# INSTALLATION GUIDE



## APPLICATION

## MODEL YR

Ford F150 Reg Cab	2009-2014
Ford F150 SuperCab	2009-2014
Ford F150 SuperCrew	2009-2014

### Tools Required:

- Torque Wrench
- 10mm socket
- 3/8" drive ratchet
- 3" 3/8" drive extension

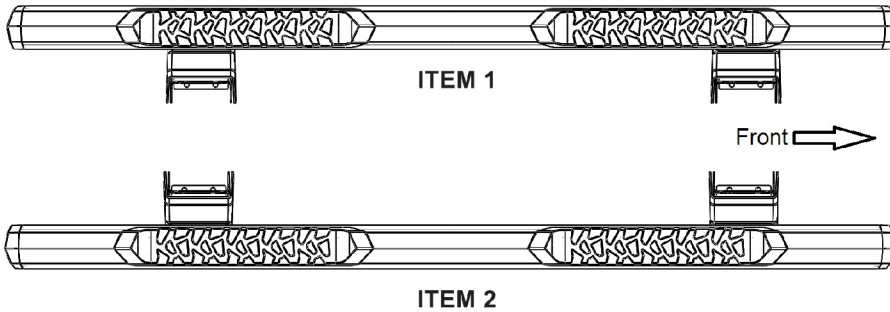
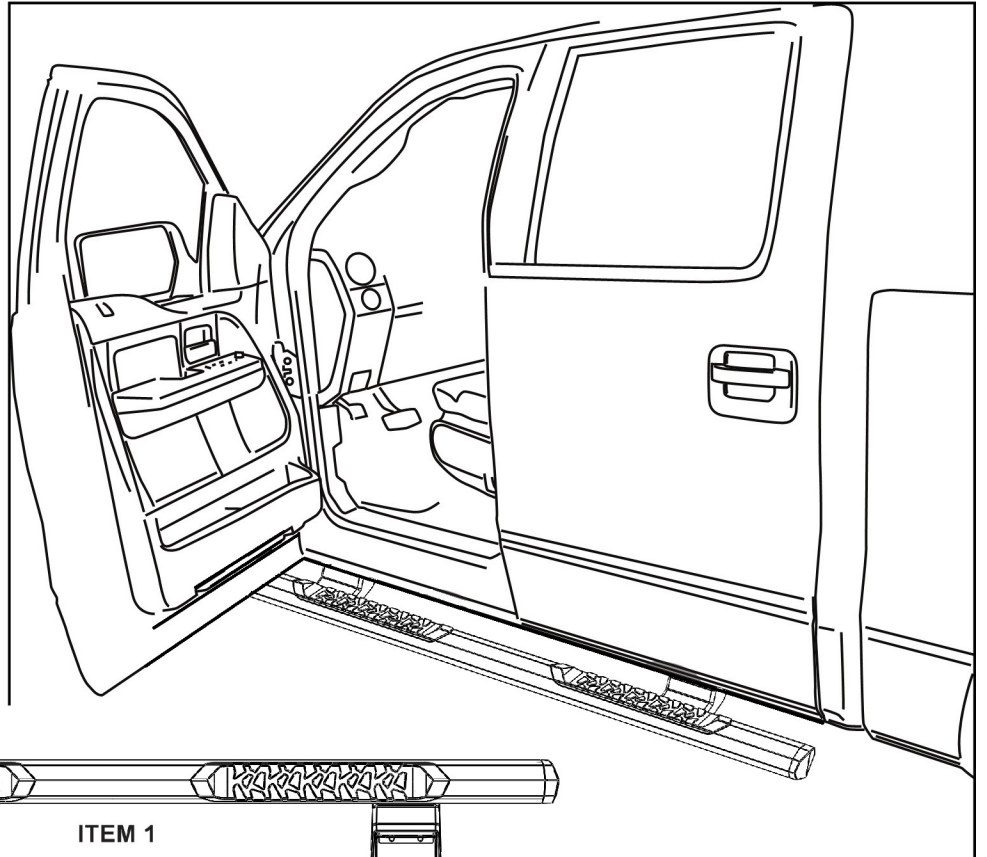
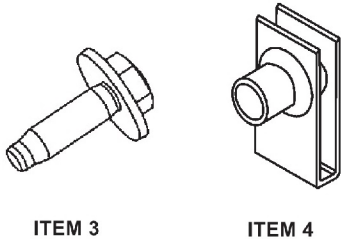

**SUPERCREW SHOWN  
SUPERCAB AND REG CAB  
ARE SIMILIAR**

### Torque Table:

8mm Hardware torque to 25Nm (18lbft)

### Parts List

Item	Description	Quantity		
		Regular	SuperCab	SuperCrew
1	Tube Assembly Driver Side	1	1	1
2	Tube Assembly Passenger Side	1	1	1
3	M8 X 30 mm SEMS Bolt	32	48	48
4	M8 U-Nut	16	24	24

Locate mounting points; first and last set of holes on the inner sill.

You may need to remove tape covering rectangular hole.

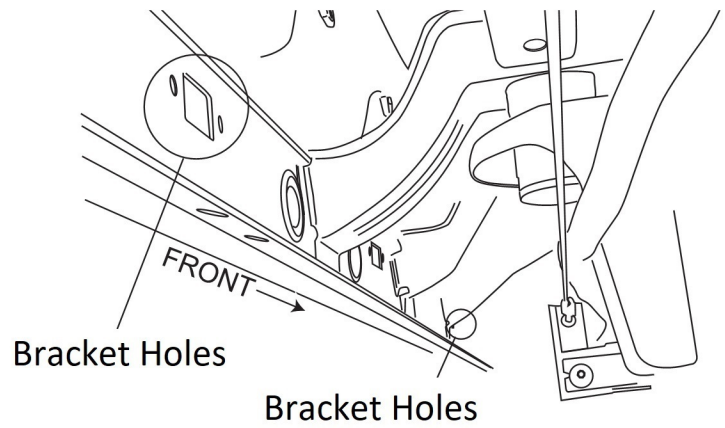

1

Drivers side pictured here.

Install M8 U-Nuts

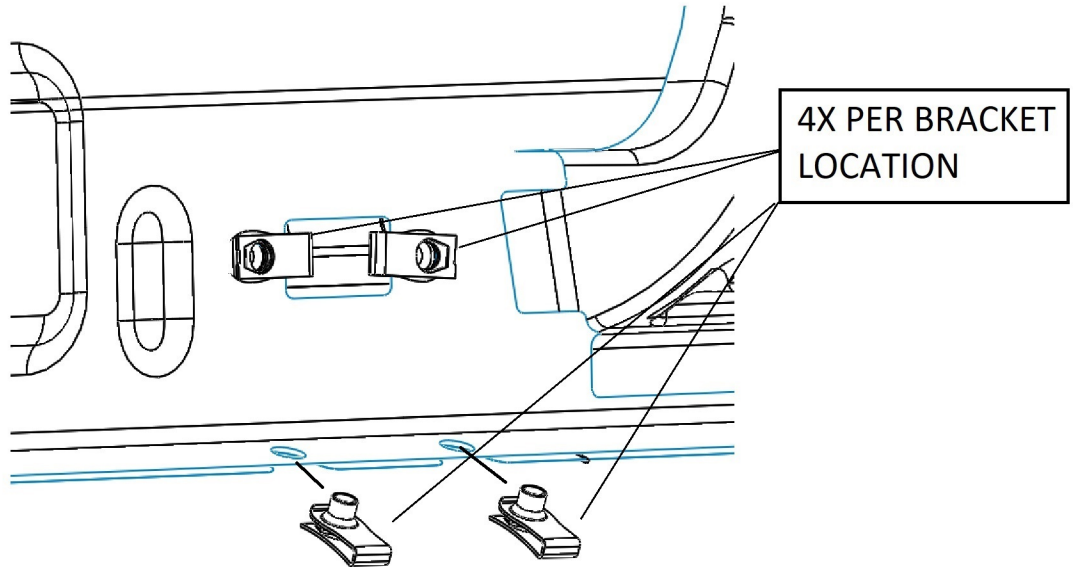

2

Install M8 SEMS Bolts - Finger Tight

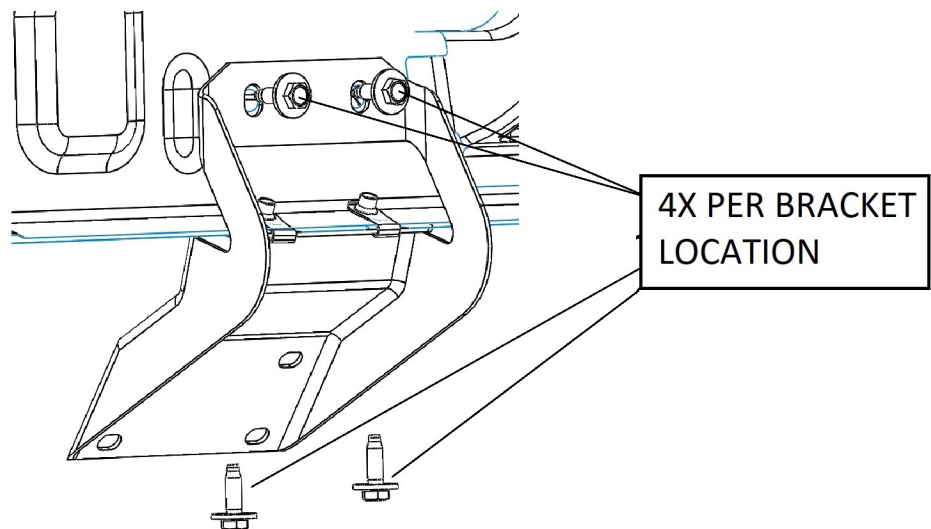

3

Set bracket covers into position on brackets. Align tab on underside of cover, into slot on top of bracket.

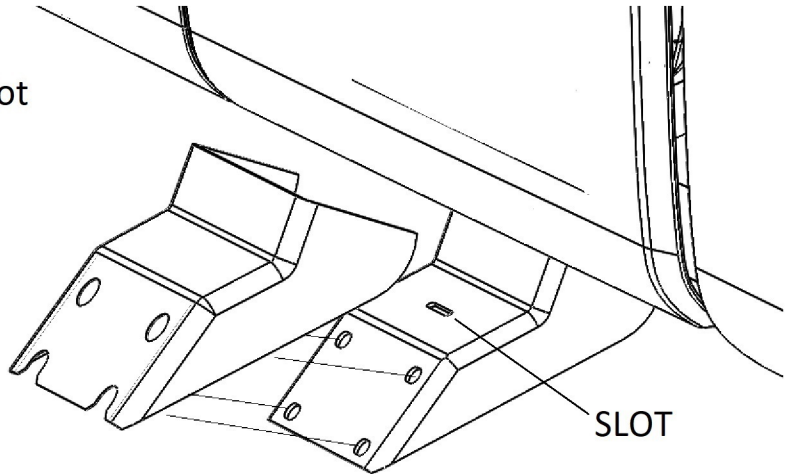

4

Attach Tube with M8 BOLTS  
Finger Tighten

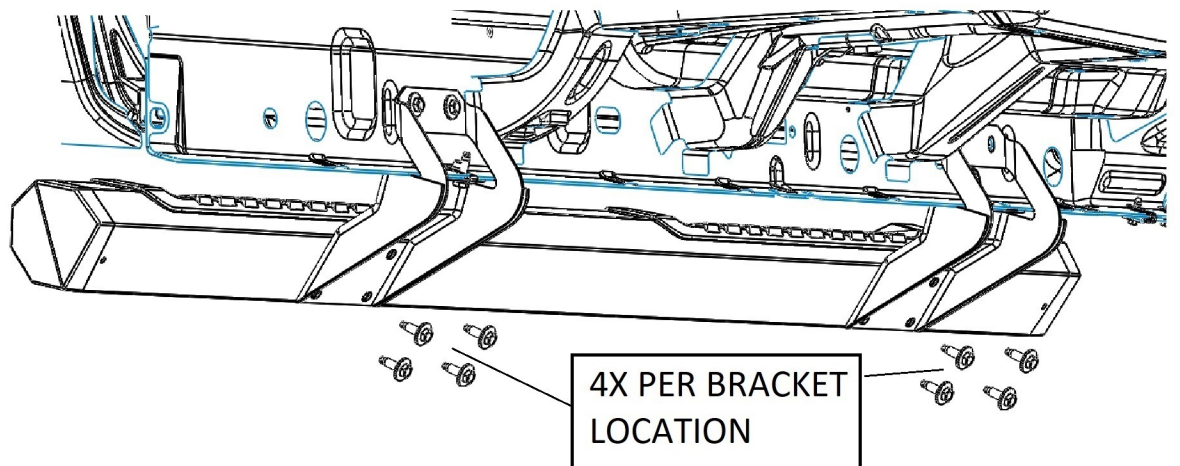

5

Tighten all flange head fasteners to 18ft-lbs  $\pm$  1 ft-lbs. (24N.m  $\pm$  1 N.m).

Repeat for Passenger Side.  
Caution - Do Not Over-Torque.

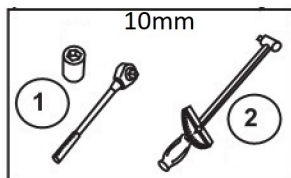

24N.m  $\pm$  1N.m(18 ft-lbs  $\pm$  1ft-lbs)

**GEMO**  
**TUBE PRODUCTS**

Made by Maxway International  
Ltd. Ontario, Canada.  
1-800-918-8316  
info@maxwayint.com

6