

# GEMO

## TUBE PRODUCTS

BRACKET KIT FOR T3 SERIES RUNNINGBOARDS  
(ORDER T3 RUNNINGBOARDS SEPERATELY)

VEHICLE APPLICATION(S):

- 2016 → NISSAN TITAN XD - CREW CAB
- 2004 → 2018 NISSAN TITAN KING & CREW CAB

LHS SHOWN, RH OPPOSITE

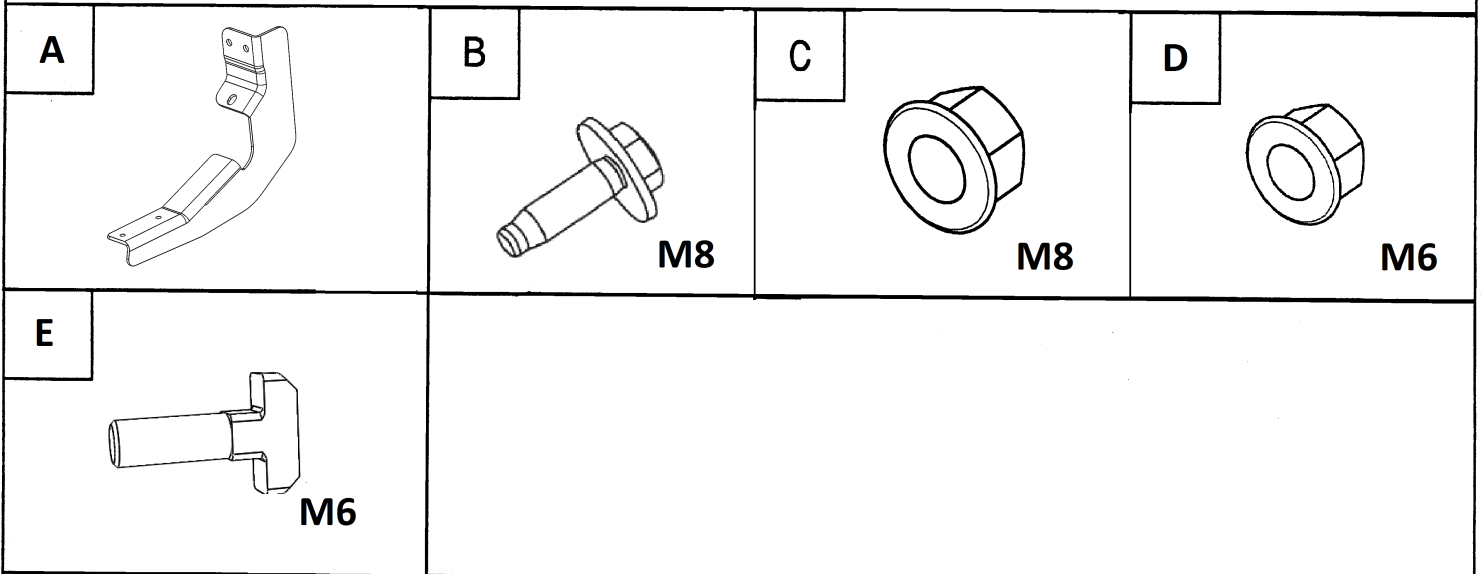

TOOLS REQUIRED  
HERRAMIENTAS NECESARIAS  
OUTILS NÉCESSAIRES

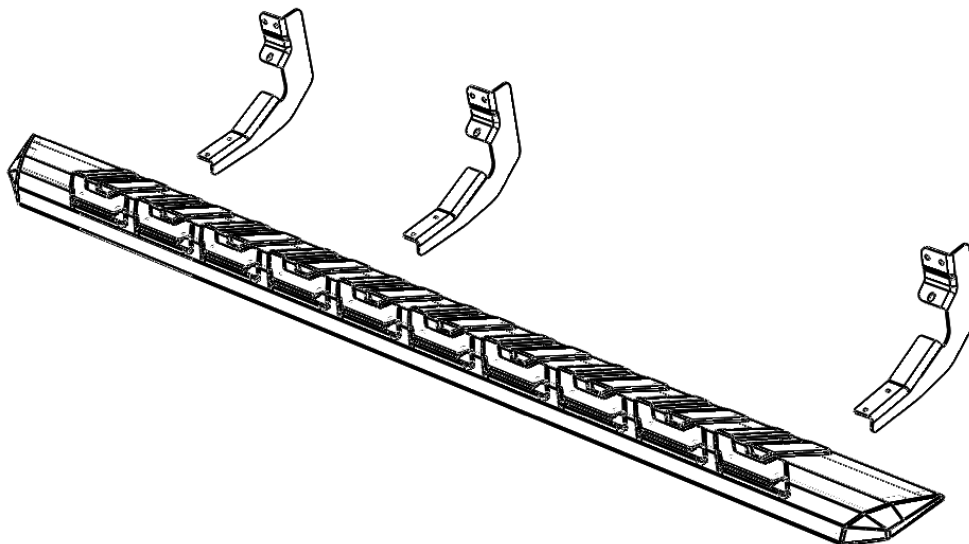
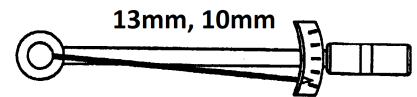
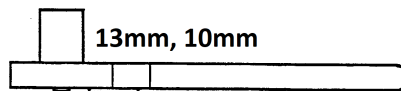

# GEMO

## TUBE PRODUCTS

Made by Maxway International  
Ltd. Ontario, Canada.  
1-800-918-8316  
info@maxwayint.com

From underneath the truck, locate the mounting locations on the inner rocker panel. Depending on the age of your truck, some will have M8 threaded holes, threaded studs or a combination of both.

For vehicles with threaded holes, loosely install bracket (Item A) to inner rocker using provided M8 SEMS bolt (Item B). For vehicles with threaded studs protruding from inner rocker, attach brackets with provided M8 Flange Nuts (Item C). **INSTALL FINGER TIGHT ONLY AT THIS TIME.**

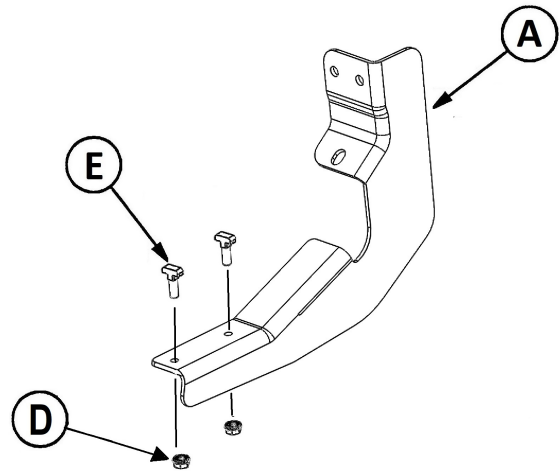

NOTE: On some vehicles you may need to remove and discard plastic plug to access threaded holes

2

At each bracket, install from above a M6 T-bolt (Item E) and **JUST START** threading on an M6 Nut (Item D) leaving the hardware very loose at this time.

3

Set T3 Runningboard in place, being sure to align slots over top of t-bolt fasteners.

Position board fore-aft along brackets for best appearance.

**PUSH UP AND TURN**, M6 nuts from below to engage the t-bolt across t-bolt slot. Finger tighten at all locations.

Double check engagement at each slot by lifting up on board. It should be secure.

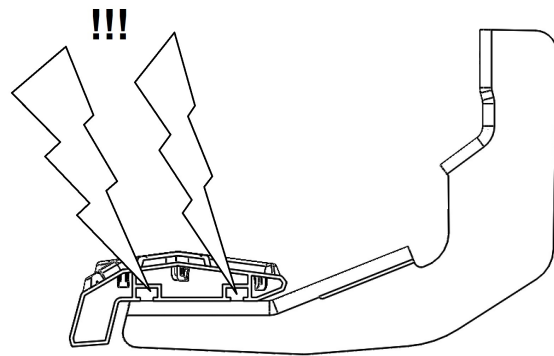

**CAUTION!! - Be sure to engage t-bolts into slots. Push UP and TURN to tighten. Verify t-bolts are engaged before torquing fasteners.**

