

PROFESSIONAL TURRET FLARE TOOL & 37° UPGRADE KIT INSTRUCTIONS

Manufactured to a high standard this product will, if used according to these instructions and properly maintained, give you years of trouble free performance.



IMPORTANT: PLEASE READ THESE INSTRUCTIONS CAREFULLY. NOTE THE SAFE OPERATIONAL REQUIREMENTS, WARNINGS AND CAUTIONS. USE THIS PRODUCT CORRECTLY AND WITH CARE, FOR THE PURPOSE FOR WHICH IT IS INTENDED. FAILURE TO DO SO MAY CAUSE DAMAGE AND/OR PERSONAL INJURY AND WILL INVALIDATE THE WARRANTY. PLEASE KEEP THESE INSTRUCTIONS SAFE FOR FUTURE USE.

1. SAFETY INSTRUCTIONS

WARNING! Ensure general workshop practice requirements are adhered to when using this equipment. Familiarize yourself with the application and limitations, as well as the potential hazards of the kit.

This kit is suitable for flaring copper, brass, steel or thin walled aluminum tube. Maintain the kit in good condition.

Replace or repair damaged parts. Use genuine parts only. Unauthorized parts may be dangerous and will invalidate the warranty.

Locate the flaring tool in a suitable work area, keep the area clean and tidy and ensure there is adequate lighting.

WARNING! Always wear approved eye or face protection when using the flaring tools.

Keep children and unauthorized persons away from the working area.

DO NOT use the kit for any purpose other than for which it is designed.

DO NOT use the kit if any parts are damaged or missing as this may cause failure and/or personal injury.

DO NOT allow untrained persons to use the kit.

DO NOT attempt to flare when you are tired.

When not in use clean kit components, replace in case and store in a safe, dry, childproof area.

WARNING! The warnings, cautions and instructions discussed in this manual cannot cover all possible conditions and situations that may occur. It must be understood that common sense and caution are factors which cannot be built into this product, but must be applied by the operator.

CHART 1

ISO BUBBLE FLARE			SAE DOUBLE FLARE			
TUBE ØDIA	OP.1 PUNCH	DIE SET	TUBE ØDIA	OP.1 PUNCH	OP.2 PUNCH	DIE SET
4.75mm	4.75mm DIN	4.75mm DIN	3/16"	3/16"	3/16" / 1/4"	3/16" 45 deg
3/16"	3/16"	3/16" DIN	1/4"	1/4"	3/16" / 1/4"	1/4" 45 deg
			5/16"	5/16"	5/16" / 3/8"	5/16" 45 deg
			3/8"	3/8"	5/16" / 3/8"	3/8" 45 deg

* OP.0 Punch can be used to ensure tube is flush with the end of the die

4LIFETIMELINES.COM

2. OPERATION

WARNING! Before using the flaring kit, ensure that you have read and understood the Safety Instructions in Section 1. Ensure you are familiar with the various types of flares before using this equipment.

PREPARATION OF THE BRAKE TUBE

- 2.1.1. The end of the tube must be cut square.
- 2.1.1.1. If you purchased the LTFL-237 37° Flaring Turret, simply remove the 45° turret by twisting and pulling up. Install the 37° by pushing down and twisting the unit on to the turret base. And follow the instructions below.
- 2.1.2. The outside edge of the tube must be chamfered approx 0.25mm x 45°.
- 2.1.3. The bore of the tube must be de-burred (Use a de-burring tool).
- 2.1.4. If the tube is plastic covered, this must be removed for 3mm from the end of the tube to be flared. Ensure the tube is not scored or any metal removed during the operation. **DO NOT** use abrasive cloth. Blow any debris from the tube after flaring.
- 2.2. Clamp the tool in a suitable bench mounted vice. Assemble the lever onto the cam as shown. Loosen the clamping screw to allow the clamp to swing open.
- 2.3. The tube end to be flared must be cut clean and square (Use a ratcheting tubing cutter).
- 2.4. Consult Chart 1 and select the die specified to produce the required flare. Place the die into the cavity as shown with the split line horizontal and the counterbore towards the operating lever (Fig. 1).
- 2.5. After the tube has been prepared as instructed above, ensure the tube nut is fitted to the tube. Pass the tube through the rear of the die until the prepared end is flush with the front face of the die. Ensure that both halves of the die are contacting the die stops (Fig. 2). Swing the locking plate into position and tighten the clamping screw. Check that the position of the tube and die are still correct.
- 2.6. Select required OP.1 punch by rotating the turret so that it is facing and in line with the pipe (Fig. 3).
- 2.7. Pull the lever to engage the punch into the end of the brake tube and continue to form the flare until a solid resistance is felt (Fig. 4). Return the handle to the original position to withdraw the punch. If the required flare calls for a second operation in Chart 1, rotate the turret until the OP. 2 punch is facing and in line with the brake tube. Operate the lever to complete the form of the flare. Return the lever to the original position to withdraw the punch. Release the clamping screw and swing the clamp open and remove the dies with the tube. If necessary a gentle tap on a suitable surface will release the dies from the tube.
Check the quality of the flare to ensure the tube did not move during the flaring.

IMPORTANT

The punches and dies supplied for this tool must only be used with this equipment.

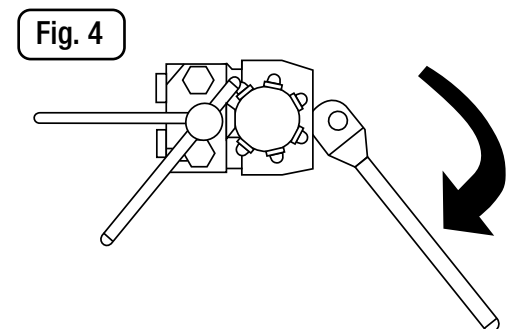
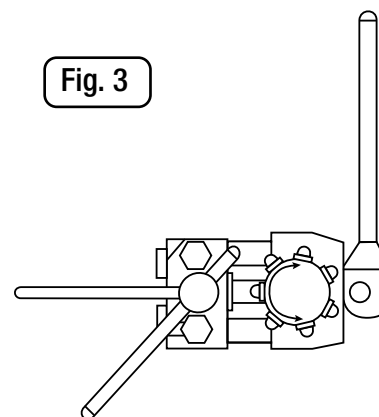
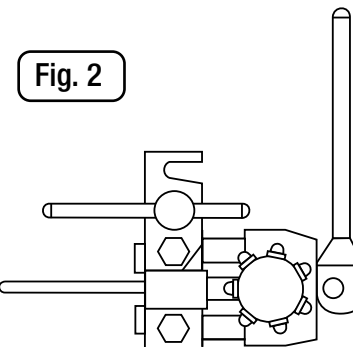
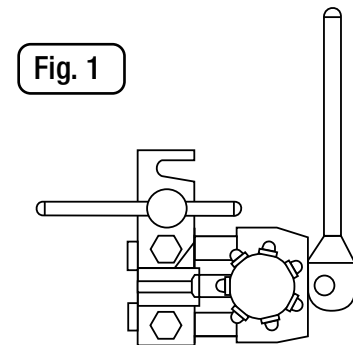

4LIFETIMELINES.COM

⚠ WARNING: Cancer & Reproductive Harm - www.P65Warnings.ca.gov

LTC000001 REV A