

# FITTING DIAGRAM

## VW MK8 GOLF R : SIDE SPLITTER INSTRUCTIONS

### INSTALLATION AND FITTING SERVICES

If you are having any difficulties please seek professional advice from the listed International and Domestic Authorised Dealers on our website.

[www.flowdesignsaustralia.com](http://www.flowdesignsaustralia.com)

## SIDE SKIRT REMOVAL NOT REQUIRED

### FITTING KIT

**a**

**M5 BOLT  
16mm LONG**

**X 2**

PLEASE NOTE:  
DRILLING REQUIRED  
TO FASTEN TO CAR BODY  
USE 5.5M DRILL BIT



**b**

**M5 BOLT  
20mm LONG**

**X 2**

PLEASE NOTE:  
DRILLING REQUIRED  
TO FASTEN TO CAR BODY  
USE 5.5M DRILL BIT



**c**

**M5 BOLT  
20mm LONG**

**X 14**

PLEASE NOTE:  
DRILLING REQUIRED  
TO FASTEN TO CAR BODY  
DO NOT OVERTIGHTEN

PILOT HOLE 5.5MM BIT  
ENLARGE WITH  
10MM DRILL BIT

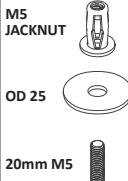

**d**

**M5 BOLT  
20mm LONG**

**X 2**

PLEASE NOTE:  
DRILLING REQUIRED  
TO FASTEN TO CAR BODY  
DO NOT OVERTIGHTEN

PILOT HOLE 5.5MM BIT  
ENLARGE WITH  
10MM DRILL BIT

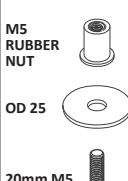

**e**

**M5 BOLT  
25mm LONG**

**X 2**

PLEASE NOTE:  
DRILLING REQUIRED  
TO FASTEN TO CAR BODY  
USE 5.5MM DRILL BIT

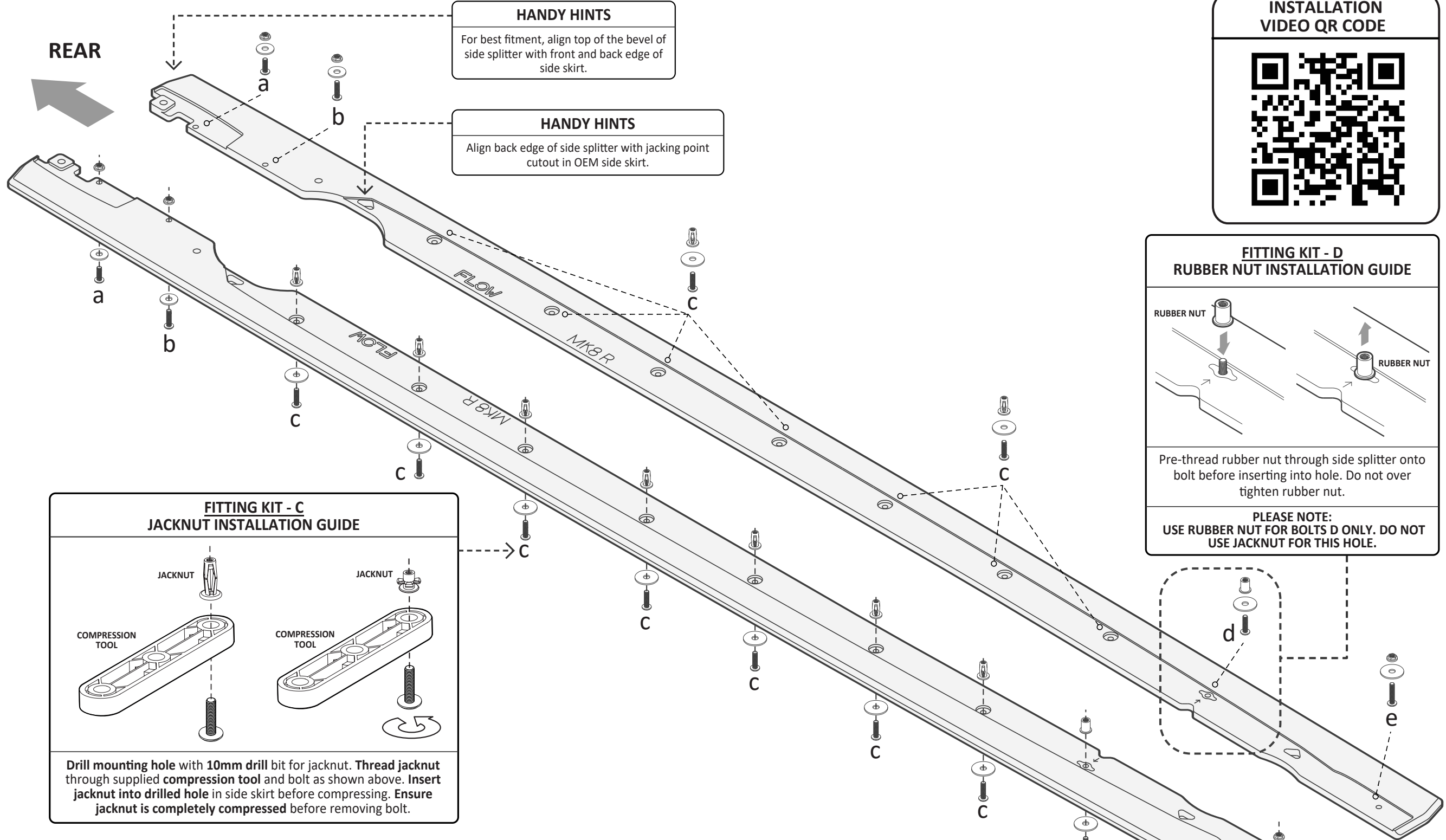
**HANDY HINTS**  
For best fitment, align top of the bevel of side splitter with front and back edge of side skirt.

**HANDY HINTS**  
Align back edge of side splitter with jacking point cutout in OEM side skirt.

**INSTALLATION VIDEO QR CODE**

**FITTING KIT - C  
JACKNUT INSTALLATION GUIDE**

Drill mounting hole with 10mm drill bit for jacknut. Thread jacknut through supplied compression tool and bolt as shown above. Insert jacknut into drilled hole in side skirt before compressing. Ensure jacknut is completely compressed before removing bolt.

**FITTING KIT - D  
RUBBER NUT INSTALLATION GUIDE**

Pre-thread rubber nut through side splitter onto bolt before inserting into hole. Do not over tighten rubber nut.

**PLEASE NOTE:  
USE RUBBER NUT FOR BOLTS D ONLY. DO NOT USE JACKNUT FOR THIS HOLE.**

**M5 JACKNUT  
COMPRESSION TOOL**

**X 1**

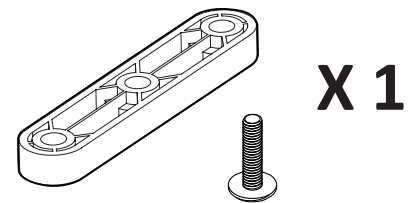

**SPARE  
JACKNUTS**

**X 2**

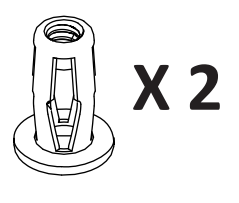

**PLEASE NOTE  
FOR ADD ON ACCESSORIES**

**DO NOT  
OVERTIGHTEN FASTENERS  
INTO BRASS FITTINGS**

HAND TIGHTEN ONLY



**FLOW  
DESIGNS**

FLOW DESIGNS AUSTRALIA  
ABN : 99 605 842 199  
10 LONGS TAFF RD  
BAYSWATER  
VIC, 3153

DESIGNED AND MANUFACTURED IN AUSTRALIA

**TERMS AND CONDITIONS: MISUSE OF GOODS**  
By taking possession of the Flow Designs Australia product, you (the buyer) agree that you have read, understood and will comply with the following disclaimer:

- This product may not be suitable for road use in your area. We cannot be held liable for any penalties or infringements that may occur after installing any of our products.
- We cannot guarantee that this product will comply with all subsequent aftermarket products you have applied to your vehicle.
- It is not legal to fit parts onto a road registered vehicle unless it carries and meets the design rules and public road regulations of your area, region and/or country.
- We do our best effort to consider safety when designing our products. We want the scene to be a safe place for everyone!

This disclaimer absolves us (Flow Designs Australia) of any and all liability or breaches to any requirement as a result of installation of our products.

[www.flowdesignsaustralia.com](http://www.flowdesignsaustralia.com)

**HANDY HINTS**  
For best fitment, align top of the bevel of side splitter with front and back edge of side skirt.