

CRASHBAR BRACKET
INSTALLATION **BUMPER ON**



VW MK8 GOLF R FRONT SPLITTER & CRASH BAR BRACKET INSTRUCTIONS

PLEASE SCAN QR CODE
TO WATCH INSTRUCTIONAL VIDEO
BEFORE INSTALLING

CRASHBAR BRACKET
INSTALLATION **BUMPER OFF**

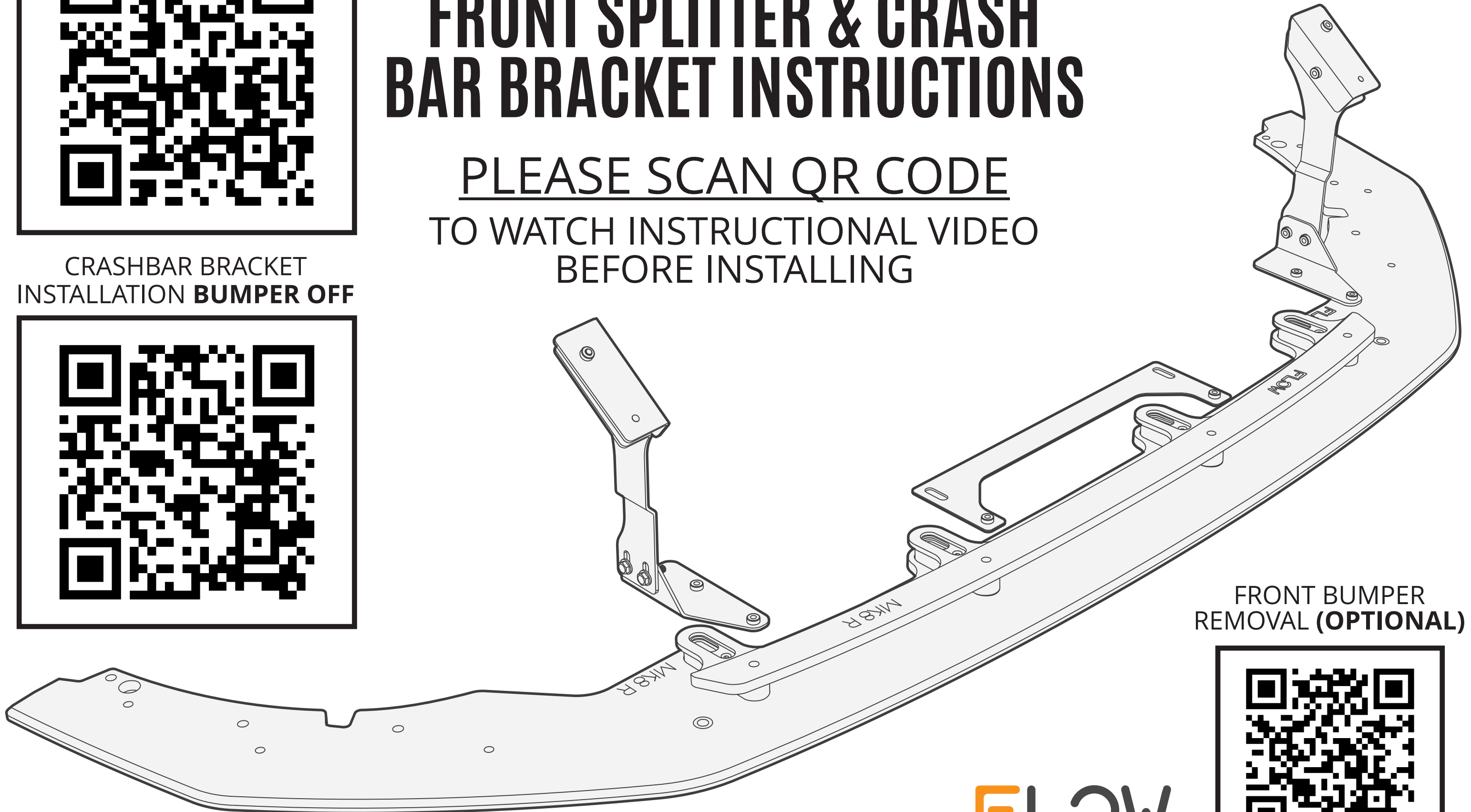
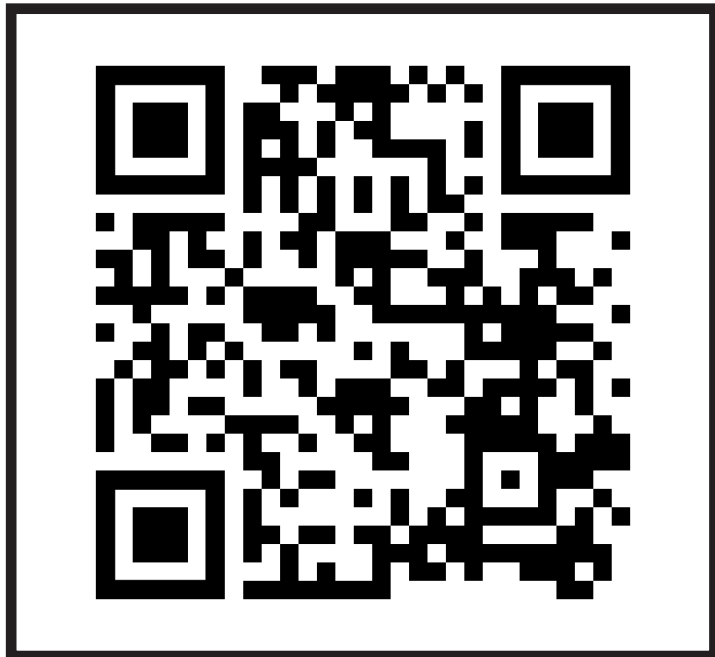

FRONT BUMPER
REMOVAL (**OPTIONAL**)

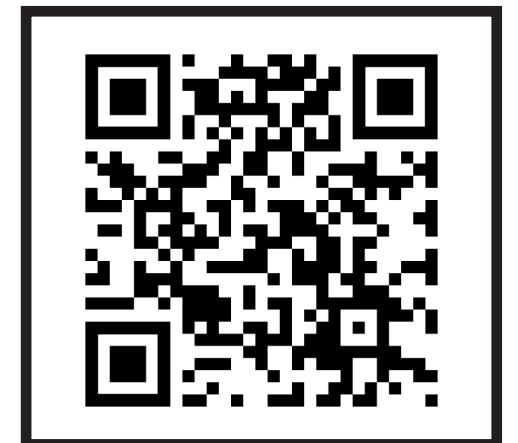

BRACKET ASSEMBLY GUIDE

VW MK8 GOLF R - FRONT SPLITTER & CRASH BAR BRACKET INSTRUCTIONS

INSTALLATION AND FITTING SERVICES

If you are having any difficulties please seek professional advice from the listed International and Domestic Authorised Dealers on our website.

www.flowdesignsaustralia.com

**FRONT BUMPER
REMOVAL
RECOMMENDED**

RIGHT BRACKET

LEFT BRACKET

HANDY HINT

Loosely mount bracket upright to top plate through OEM crashbar, before evenly tightening mounting hardware.

HANDY HINT

Place top plate over crashbar and stud through OEM hole.

HANDY HINT

Ensure bracket base plates are mounted on the correct side of the upright as shown in the diagram.

BRACKET FITTING KIT

1a

**FLANGED M6 BOLT
20mm LONG**

X 8

PLEASE NOTE:
ENSURE BOLTS HAVE
BEEN TIGHTENED
BEFORE INSTALLING
SPLITTER

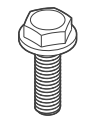

FLANGED
20mm M6

1b

**M6 FLANGE
NUT**

X 2

PLEASE NOTE:
ENSURE BOLTS HAVE
BEEN TIGHTENED
BEFORE INSTALLING
SPLITTER.
MOUNT FLANGE NUT
TO STUD ON BRACKET



FLANGE
NUT

HANDY HINT

Drill mounting holes for splitter before loosely threading bracket mounting bolts and splitter fitting kit to bracket baseplate. Tighten splitter mounting bolts then adjust bracket bolts (1a) to suit.

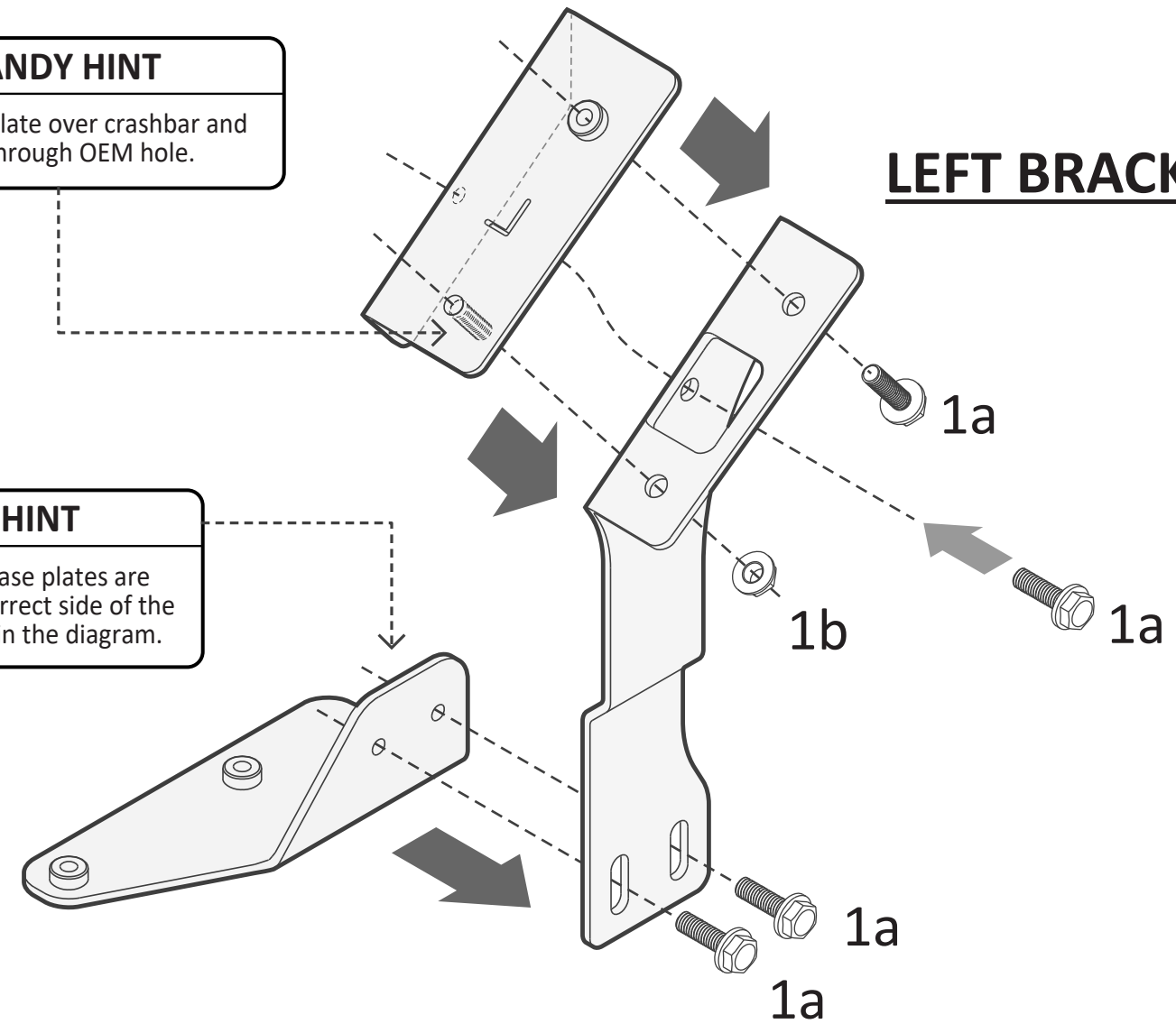
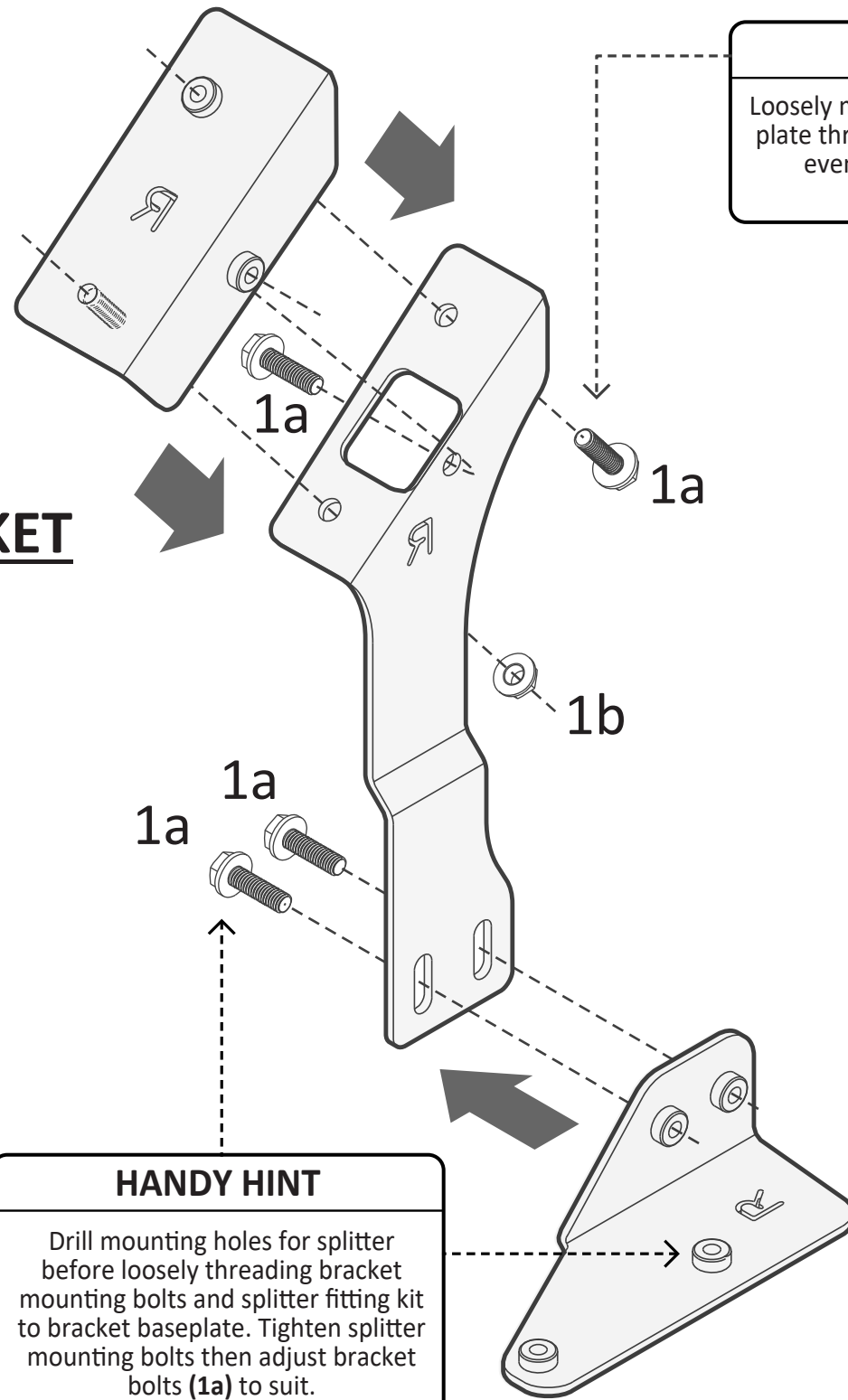

BRACKET UPRIGHTS (PAIR)

X 1

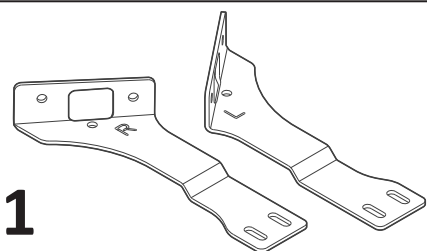

BRACKET BASE PLATES (PAIR)

X 1

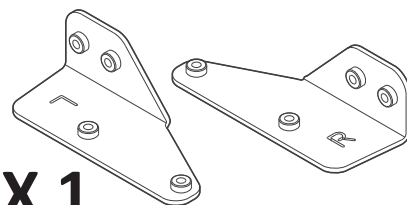

BRACKET TOP PLATE (PAIR)

X 1

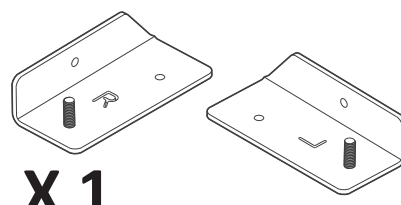

REINFORCEMENT PLATE

X 1

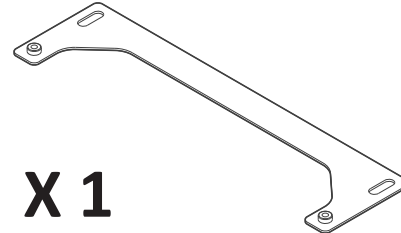

TERMS AND CONDITIONS: MISUSE OF GOODS

By taking possession of the Flow Designs Australia product, you (the buyer) agree that you have read, understood and will comply with the following disclaimer:

- This product may not be suitable for road use in your area. We cannot be held liable for any penalties or infringements that may occur after installing any of our products.
- We cannot guarantee that this product will comply with all subsequent aftermarket products you have applied to your vehicle.
- It is not legal to fit parts onto a road registered vehicle unless it carries and meets the designs rules and public road regulations of your area, region and/or country.
- We do our best effort to consider safety when designing our products. We want the scene to be a safe place for everyone!

This disclaimer absolves us (Flow Designs Australia) of any and all liability or breaches to any requirement as a result of installation of our products.

www.flowdesignsaustralia.com

INSTRUCTIONAL VIDEO QR CODE



BRACKET INSTALLATION GUIDE

VW MK8 GOLF R - FRONT SPLITTER & CRASH BAR BRACKET INSTRUCTIONS

INSTALLATION AND FITTING SERVICES

If you are having any difficulties please seek professional advice from the listed International and Domestic Authorised Dealers on our website.

www.flowdesignsaustralia.com

**FRONT BUMPER
REMOVAL
RECOMMENDED**

CRASH BAR BRACKET INSTALLATION GUIDE

1. Bracket can be installed with bumper on however is more difficult to access mounting hardware. **Remove front bumper** for ease of installation.
2. Place **bracket top plate** over OEM crashbar and align stud with lower OEM hole.
3. **Mount bracket upright** to the top plate through the OEM crashbar and using hardware **1a** and **1b** to the stud as shown in **Diagram A**.
4. **Secure the bracket top plate** to the bracket upright by mounting the hardware **1a** through the side of the OEM crashbar as shown in **Diagram B**. **Tighten all hardware** attaching bracket to OEM crashbar.
5. **Align splitter** and mount to bumper before **drilling mounting holes** for crash bar bracket as shown in **Diagram C**. Drill towards the back of the elongated hole.
6. **Insert reinforcement plate** into front bumper below the lower crashbar and mount using supplied splitter fitting kit.
7. **Insert bracket base plates** into front bumper and align with drilled mounting holes.
8. Lightly thread mounting hardware to secure bracket base plate to splitter and bracket baseplate to bracket upright as shown in **Diagram E**.
9. **Tighten all mounting hardware** for crash bar bracket and splitter to complete splitter installation.

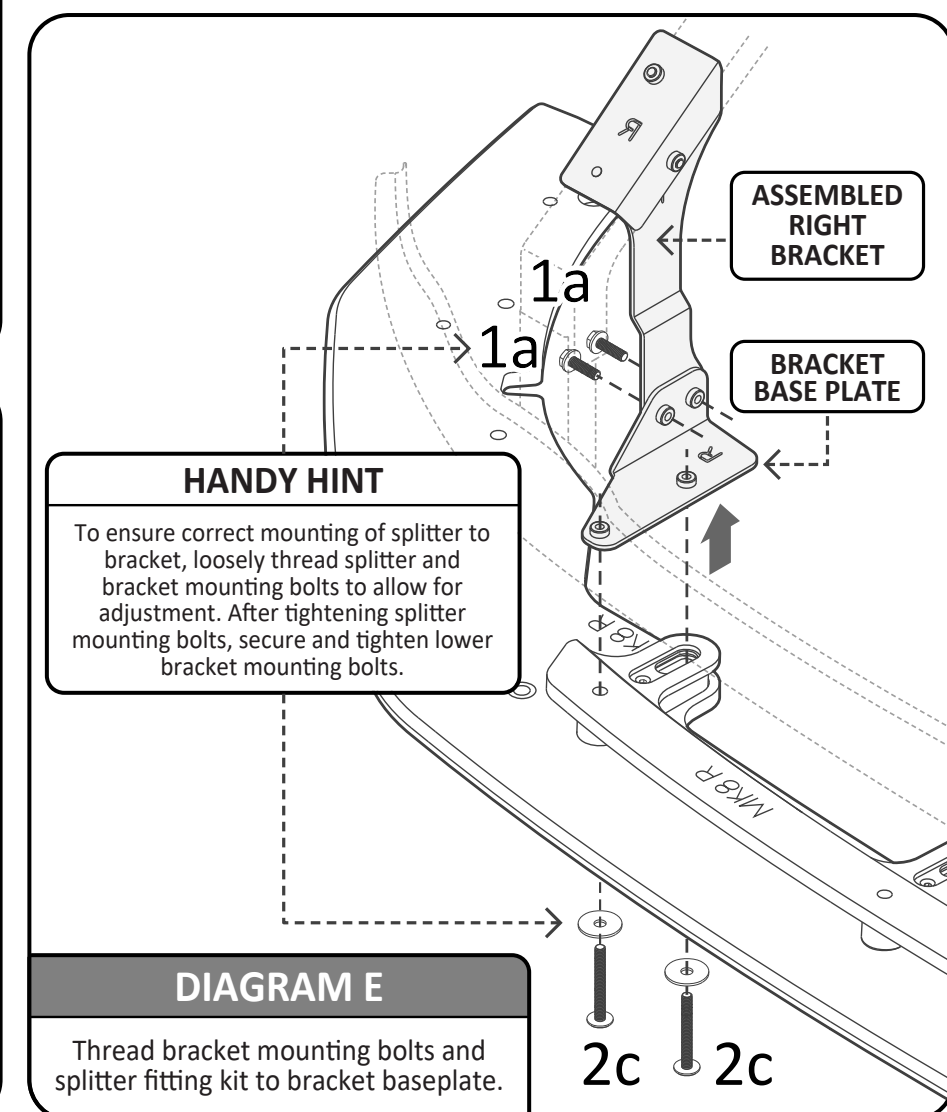
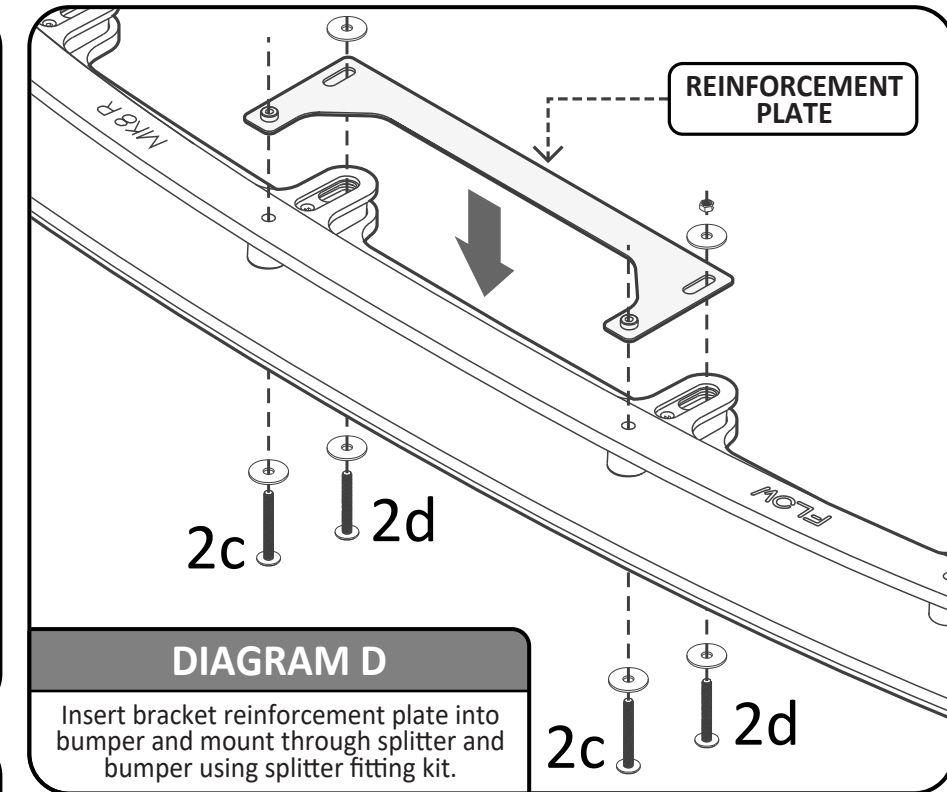
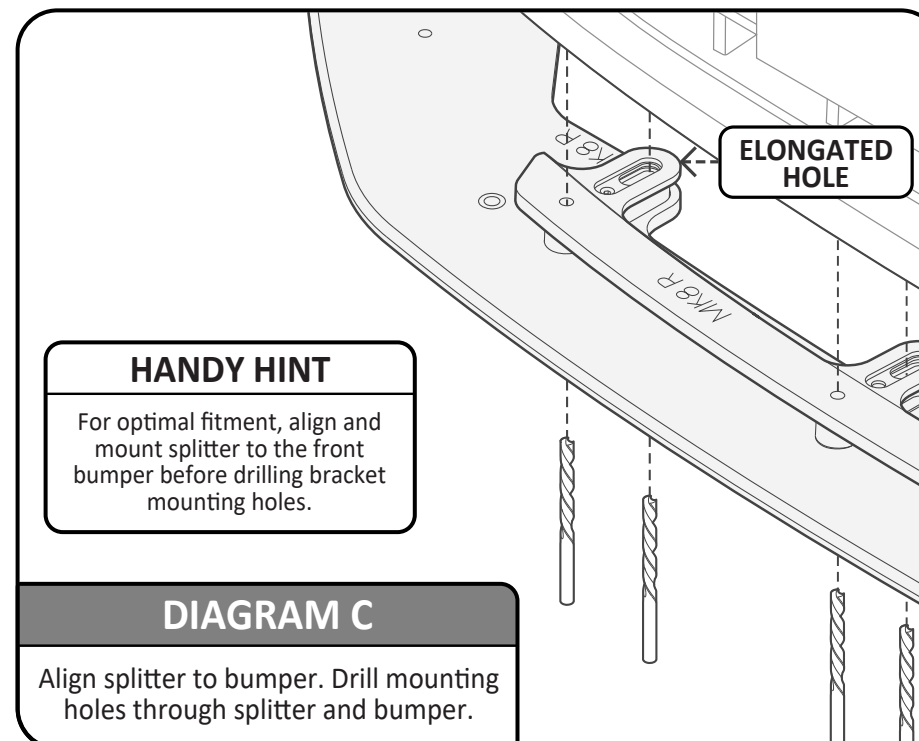
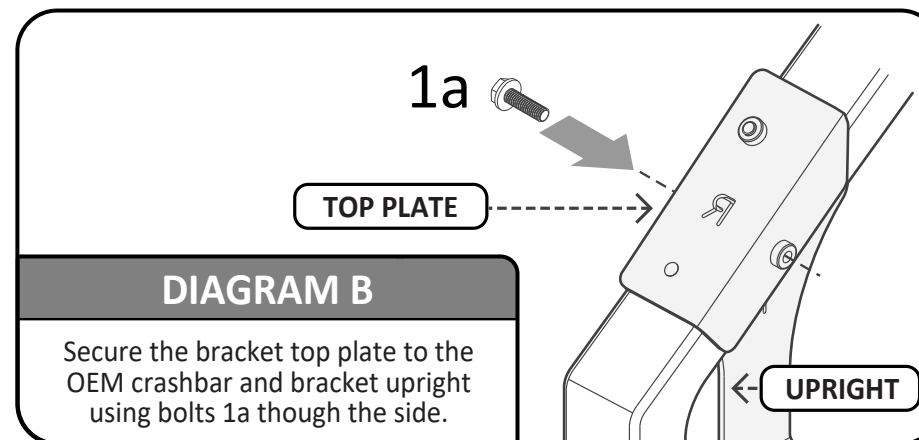
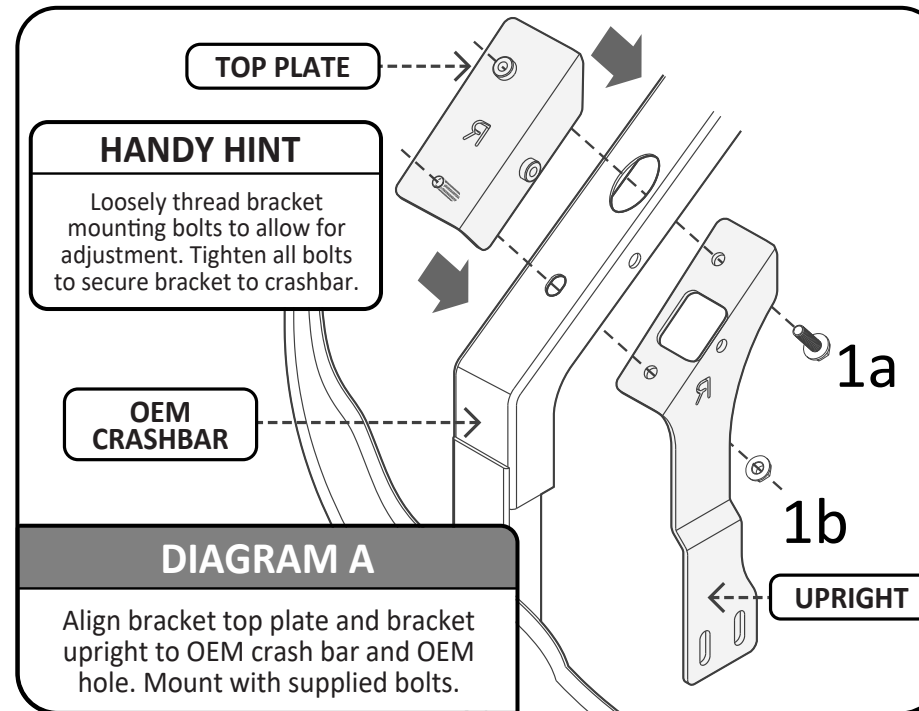

INSTRUCTIONAL
VIDEO QR CODE



TERMS AND CONDITIONS: MISUSE OF GOODS
By taking possession of the Flow Designs Australia product, you (the buyer) agree that you have read, understood and will comply with the following disclaimer:

- This product may not be suitable for road use in your area. We cannot be held liable for any penalties or infringements that may occur after installing any of our products.
- We cannot guarantee that this product will comply with all subsequent aftermarket products you have applied to your vehicle.
- It is not legal to fit parts onto a road registered vehicle unless it carries and meets the designs rules and public road regulations of your area, region and/or country.
- We do our best effort to consider safety when designing our products. We want the scene to be a safe place for everyone!

This disclaimer absolves us (Flow Designs Australia) of any and all liability or breaches to any requirement as a result of installation of our products.

www.flowdesignsaustralia.com

FITTING DIAGRAM

VW MK8 GOLF R - FRONT SPLITTER & CRASH BAR BRACKET INSTRUCTIONS

INSTALLATION AND FITTING SERVICES

If you are having any difficulties please seek professional advice from the listed International and Domestic Authorised Dealers on our website.

www.flowdesignsaustralia.com

FRONT BUMPER REMOVAL RECOMMENDED

FLOW
DESIGNS

FLOW DESIGNS AUSTRALIA
ABN : 99 605 842 199
10 LONGSTAFF RD
BAYSWATER
VIC. 3153



TERMS AND CONDITIONS: MISUSE OF GOODS

By taking possession of the Flow Designs Australia product, you (the buyer) agree that you have read, understood and will comply with the following disclaimer:

- This product may not be suitable for road use in your area. We cannot be held liable for any penalties or infringements that may occur after installing any of our products.
- We cannot guarantee that this product will comply with all subsequent aftermarket products you have applied to your vehicle.
- It is not legal to fit parts onto a road registered vehicle unless it carries and meets the designs rules and public road regulations of your area, region and/or country.
- We do our best effort to consider safety when designing our products. We want the scene to be a safe place for everyone!

This disclaimer absolves us (Flow Designs Australia) of any and all liability or breaches to any requirement as a result of installation of our products.

www.flowdesignsaustralia.com

SPLITTER FITTING KIT

2a

M6 BOLT
20mm LONG

X 2

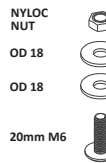

PLEASE NOTE:
DRILLING REQUIRED TO FASTEN TO BUMPER.
USE 8MM DRILL BIT

2b

M6 BOLT
25mm LONG

X 4

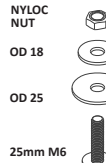

PLEASE NOTE:
DRILLING REQUIRED TO FASTEN TO BUMPER.
USE 8MM DRILL BIT

2c

M6 BOLT
55mm LONG

X 6



PLEASE NOTE:
DRILLING INTO BUMPER
REQUIRED TO FASTEN TO
CRASH BAR BRACKETS.
USE 8MM DRILL BIT

2d

M6 BOLT
45mm LONG

X 2

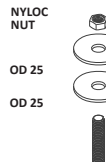

PLEASE NOTE:
DRILLING INTO BUMPER
REQUIRED TO FASTEN TO
REINFORCEMENT PLATE.
USE 8MM DRILL BIT

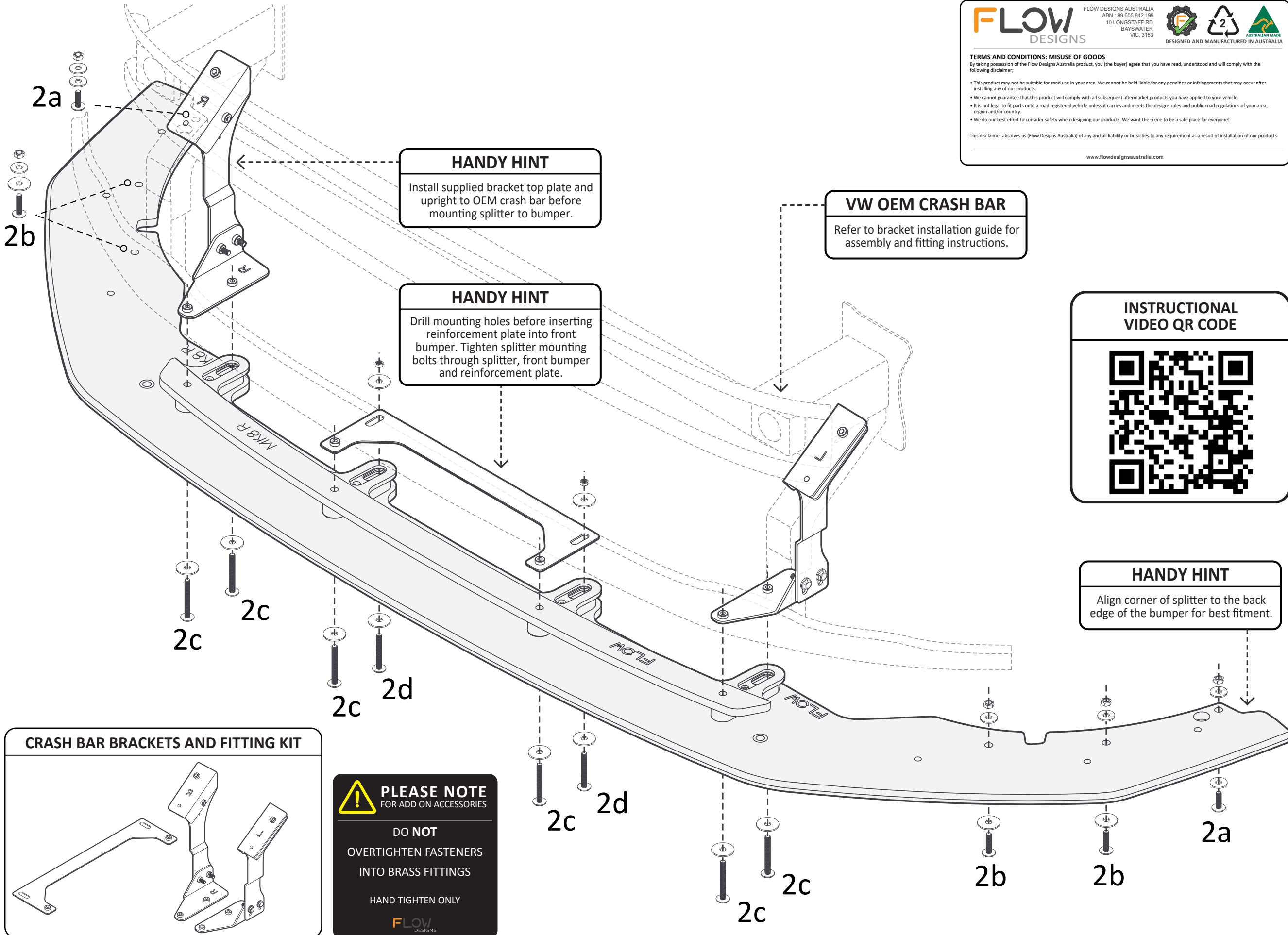

HANDY HINT

Install supplied bracket top plate and upright to OEM crash bar before mounting splitter to bumper.

HANDY HINT

Drill mounting holes before inserting reinforcement plate into front bumper. Tighten splitter mounting bolts through splitter, front bumper and reinforcement plate.

VW OEM CRASH BAR

Refer to bracket installation guide for assembly and fitting instructions.

INSTRUCTIONAL VIDEO QR CODE



HANDY HINT

Align corner of splitter to the back edge of the bumper for best fitment.

CRASH BAR BRACKETS AND FITTING KIT

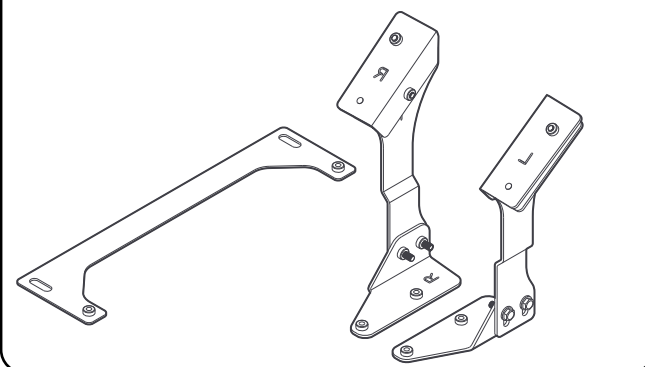

PLEASE NOTE
FOR ADD ON ACCESSORIES

DO NOT
OVERTIGHTEN FASTENERS
INTO BRASS FITTINGS

HAND TIGHTEN ONLY

FLOW
DESIGNS