

# FITTING GUIDE

## VW MK7.5 GOLF: CROSS BAR STUD INSTALLATION

INSTALLATION AND FITTING SERVICES

If you are having any difficulties please seek professional advice from the listed International and Domestic Authorised Dealers on our website.

[www.flowdesignsaustralia.com](http://www.flowdesignsaustralia.com)

**BUMPER REMOVAL  
REQUIRED**

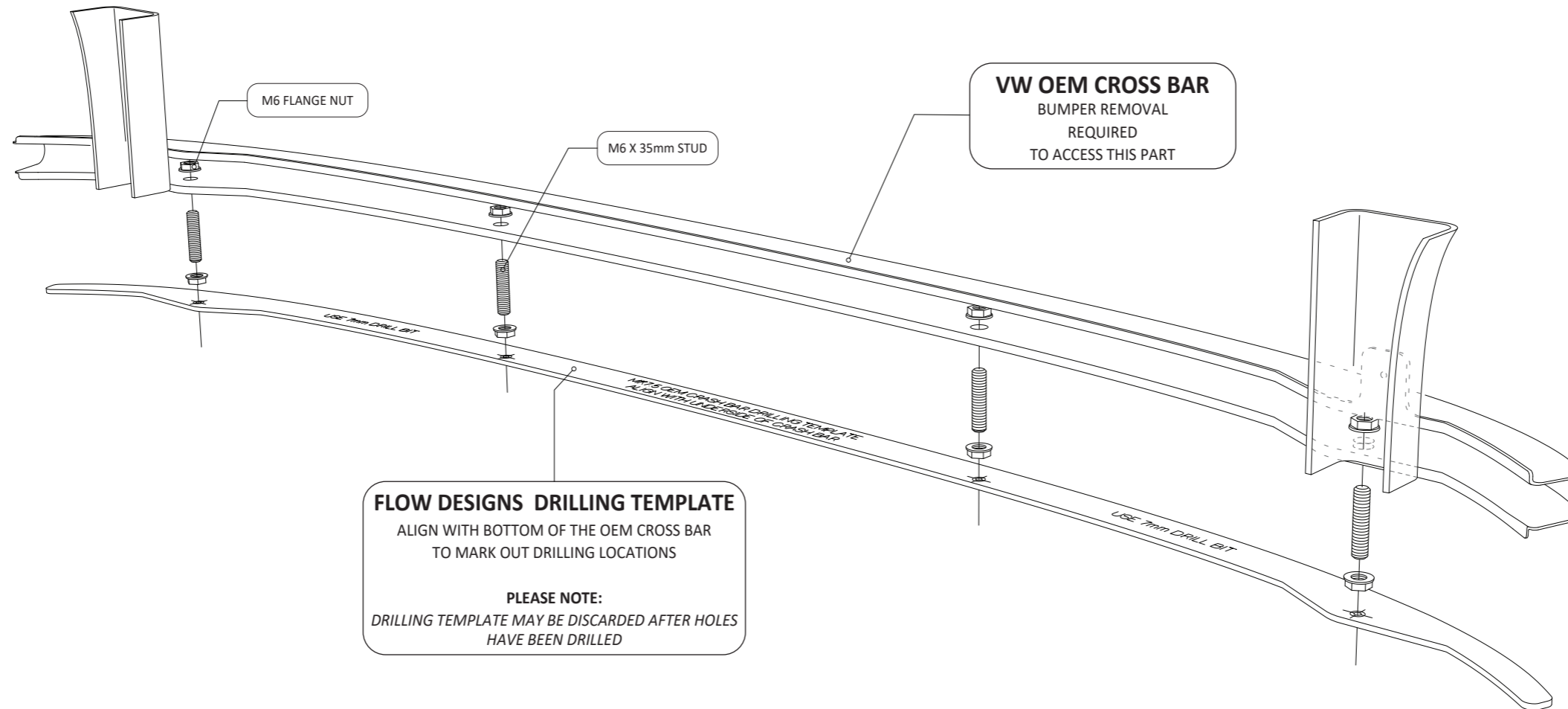

### STEP 1

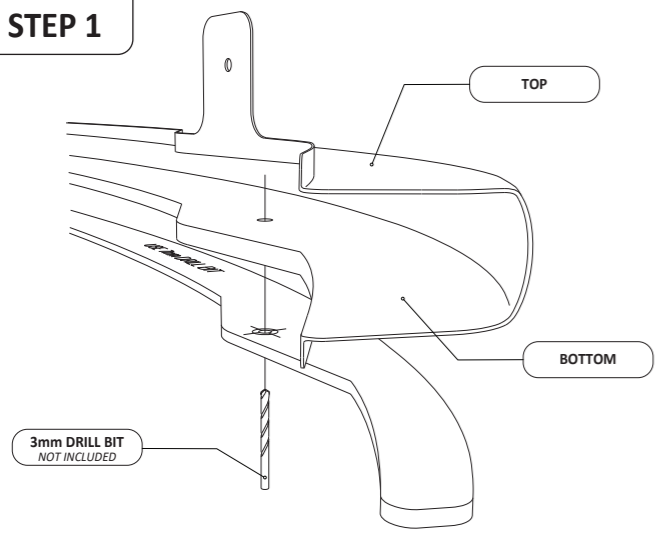

- Align drilling template with the bottom of the OEM Cross Bar.
- Ensure the drilling template is flush with the cross bar on both ends.
- Use a 3mm drill bit to drill 4 pilot holes into the cross bar.

**PLEASE NOTE :** Drill bottom side of OEM Cross Bar **ONLY**

### STEP 2

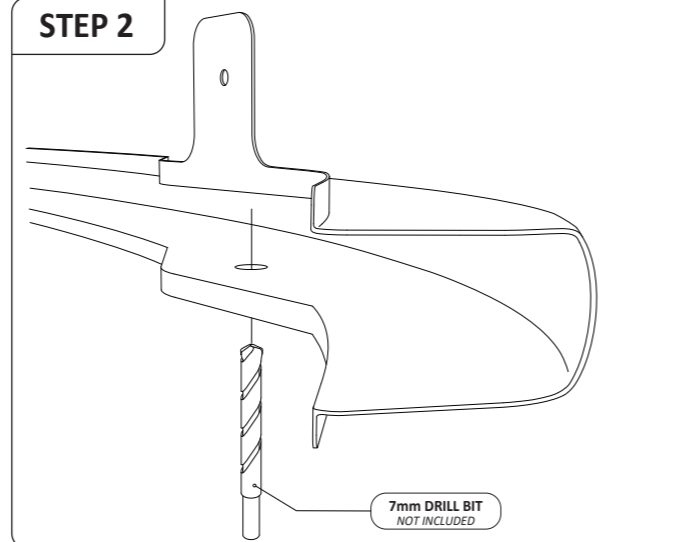

- Use a 7mm drill bit to enlarge the pilot holes to their final size.

**PLEASE NOTE :** Not recommended to drill a hole larger than 8mm

### STEP 3

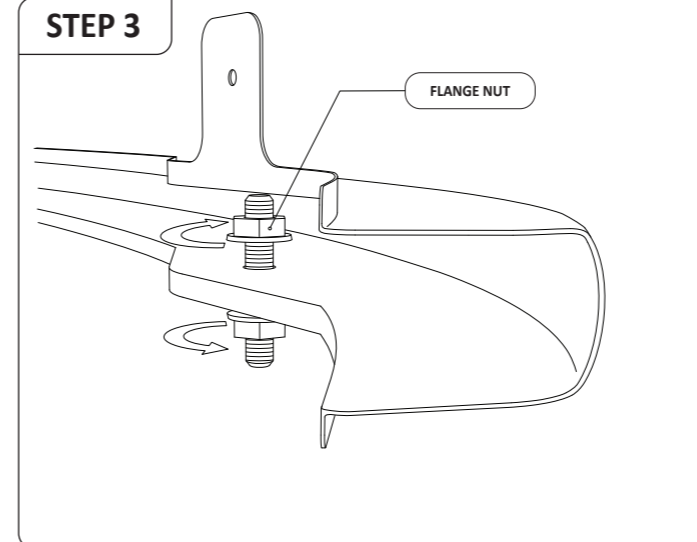

- Insert M6 x 35mm stud into the 4 holes
- Tighten flange nuts to the top and bottom of the studs.

### STEP 4

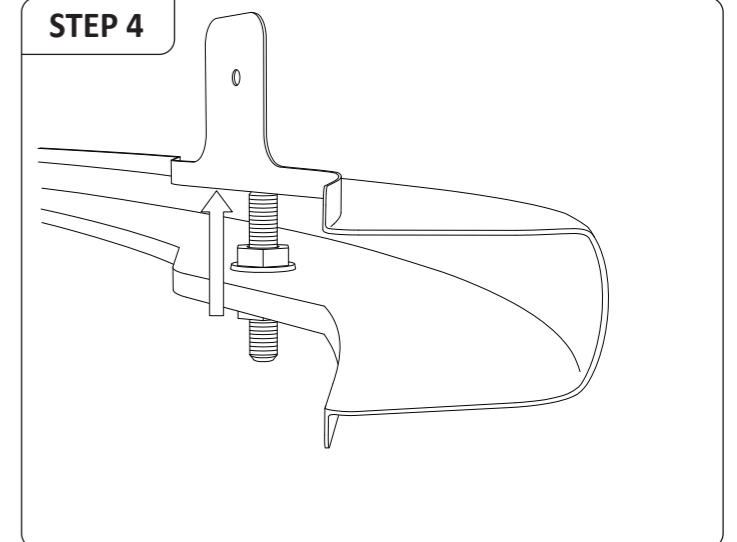

- Ensure the stud is flushed to the top section of the OEM Cross bar