

# FITTING GUIDE

## VW GOLF MK5 GTI/R32 - REAR SPOILER EXTENSION

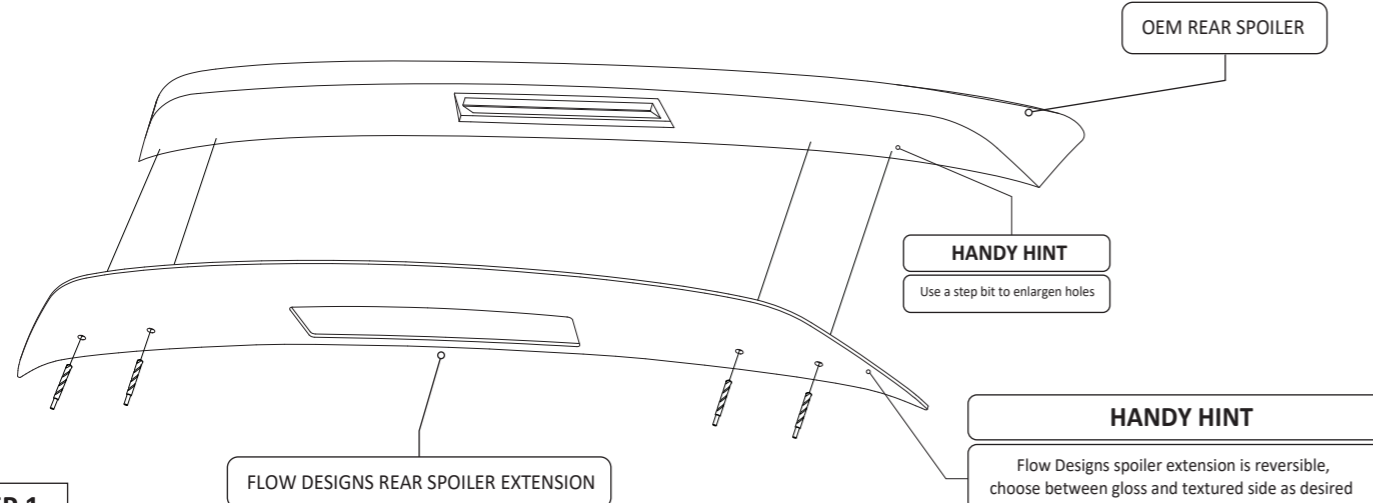

### STEP 1

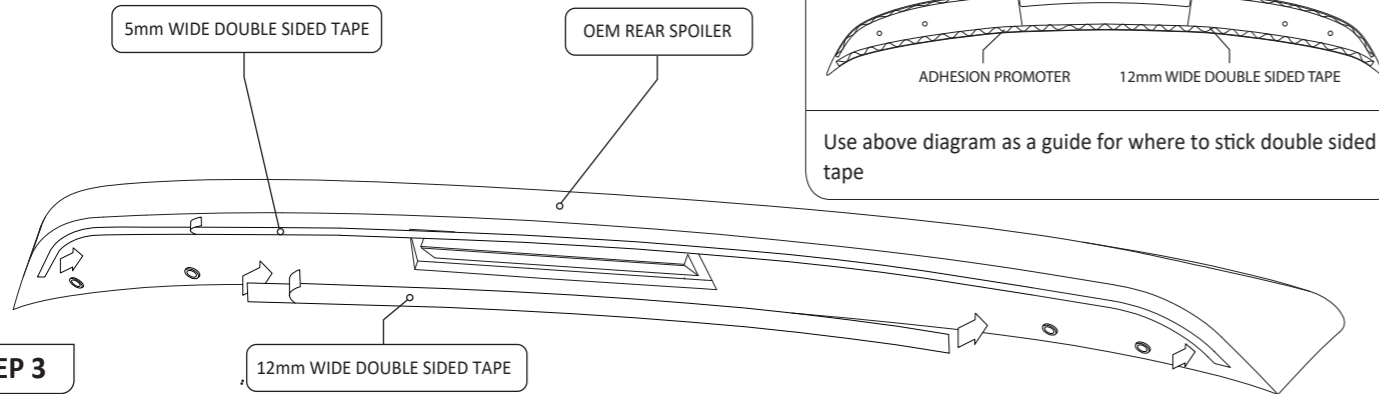

- Choose between texture or gloss side face up
- Using a 6mm drill bit and the Flow Designs Rear Spoiler Extension as a guide, drill out pilot holes in OEM spoiler
- Remove Flow Designs Rear Spoiler Extension
- Enlarge pilot holes using a 10mm step bit



### STEP 3

- Clean surface of spoiler with alcohol swab
- Apply adhesion promoter as shown in the diagram
- Apply the 12mm double sided tape **underneath** the stock brake light and the 5mm double sided tape **above** the stock break light

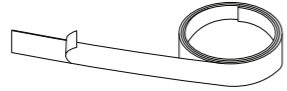
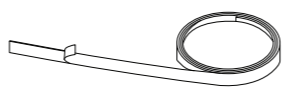
## FITTING KIT

<p><b>a</b></p> <p><b>M5 Rubber Nuts</b></p> <p><b>X 4</b></p> <p>PLEASE NOTE: DRILLING REQUIRED TO FASTEN TO OEM SPOILER DO NOT OVERTIGHTEN</p>	<p><b>b</b></p> <p><b>M5 BOLT 25mm LONG</b></p> <p><b>X 4</b></p> <p>PLEASE NOTE: DRILLING NOT REQUIRED TO FASTEN TO OEM SPOILER DO NOT OVERTIGHTEN</p>	<p>3m of 12mm wide DOUBLE SIDED TAPE</p> 	<p>2m of 5mm wide DOUBLE SIDED TAPE</p> 	<p>ALCOHOL SWAB</p> 	<p>3M ADHESION PROMOTER</p> 
--	---	--	---	---	---

### INSTALLATION AND FITTING SERVICES

If you are having any difficulties please seek professional advise from the listed International and Domestic Authorised Dealers on our website.

[www.flowdesignsaustralia.com](http://www.flowdesignsaustralia.com)

## OEM REAR SPOILER REMOVAL NOT REQUIRED

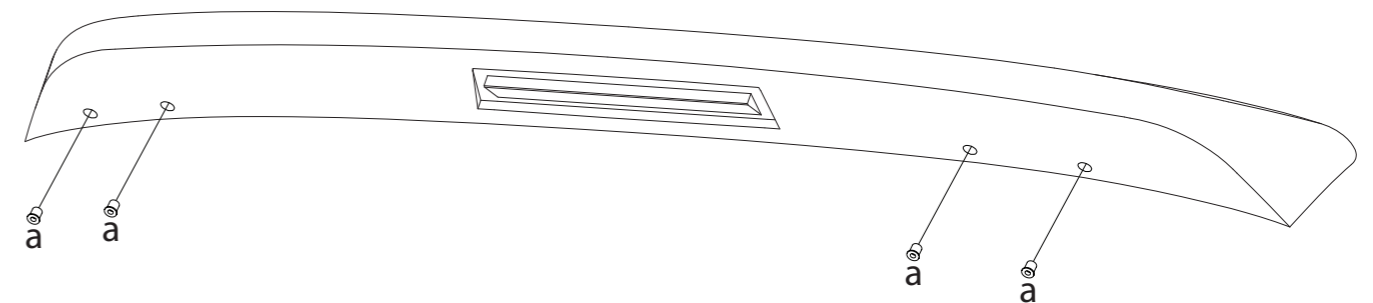

### STEP 2

- Insert Rubber Nuts (a.) into OEM Rear Spoiler

### HANDY HINT

- Clean surface with alcohol swab, then apply 3M adhesion promoter
- Once stuck to OEM Spoiler, hold in place for 10 minutes. **DO NOT** wash or drive car within 12 hours of installation

### HANDY HINTS

APPLY ADHESION PROMOTER WITHIN DASHED LINES

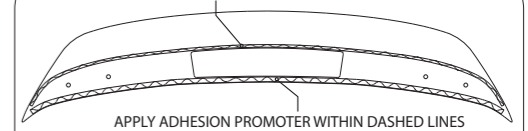

Use above diagram as a guide for where to apply the 3M adhesion promoter to the Flow Designs Rear Spoiler Extension

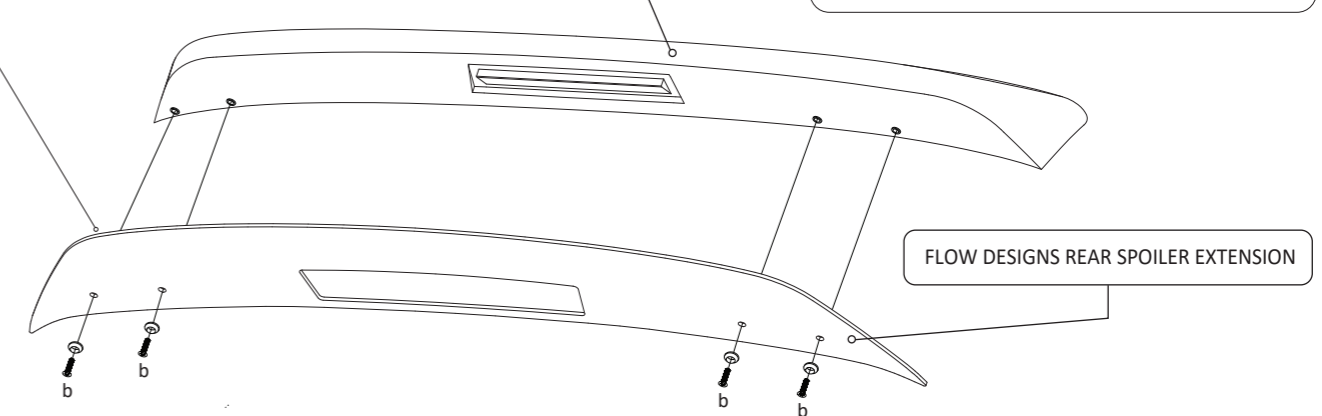

### STEP 4

- Using the bolts (b.), install Flow Designs Rear Spoiler Extension to OEM Rear Spoiler
- PLEASE NOTE : DO NOT OVERTIGHTEN - These bolts do not need to be very tight.**

**FLOW DESIGNS**

FLOW DESIGNS AUSTRALIA  
 10/100 BAYVIEW RD  
 BAYSWATER NORTH VIC 3153

DESIGNED AND MANUFACTURED IN AUSTRALIA

**TERMS AND CONDITIONS : MISUSE OF GOODS**

This Product application is not intended for public road registered vehicles within Australia. Regulations may vary from Countries outside of Australia. Please check your Country's and State's road regulations before installing on a vehicle intended for public road use.

Flow Designs Australia PTY LTD will not be liable for any liabilities in relation to any use of the goods other than in strict accordance with the Company's instructions and for the purpose and application for which the goods were supplied by the Company.

The Client undertakes with the Company:

- That it will acquaint itself with the requirements of all relevant government or statutory and other authorities, bodies or corporations relating to the goods and/or services and to the applications to which the goods and/or services are to be put;
- That at all times while the goods are in its possession or under its control it will comply with such requirements;
- That it will procure that any purchaser of goods from it will also acquaint itself with, and will comply with, such requirements;
- That it will indemnify the Company against any liability resulting from a breach of any such requirements.

[www.flowdesignsaustralia.com](http://www.flowdesignsaustralia.com)