

# FITTING DIAGRAM

VW MK6 GTI V3 : REAR SPAT + ADJUSTABLE REAR WINGLETS

INSTALLATION AND FITTING SERVICES

If you are having any difficulties please seek professional advise from the listed International and Domestic Authorised Dealers on our website.

[www.flowdesignsaustralia.com](http://www.flowdesignsaustralia.com)

**BUMPER REMOVAL  
NOT REQUIRED**

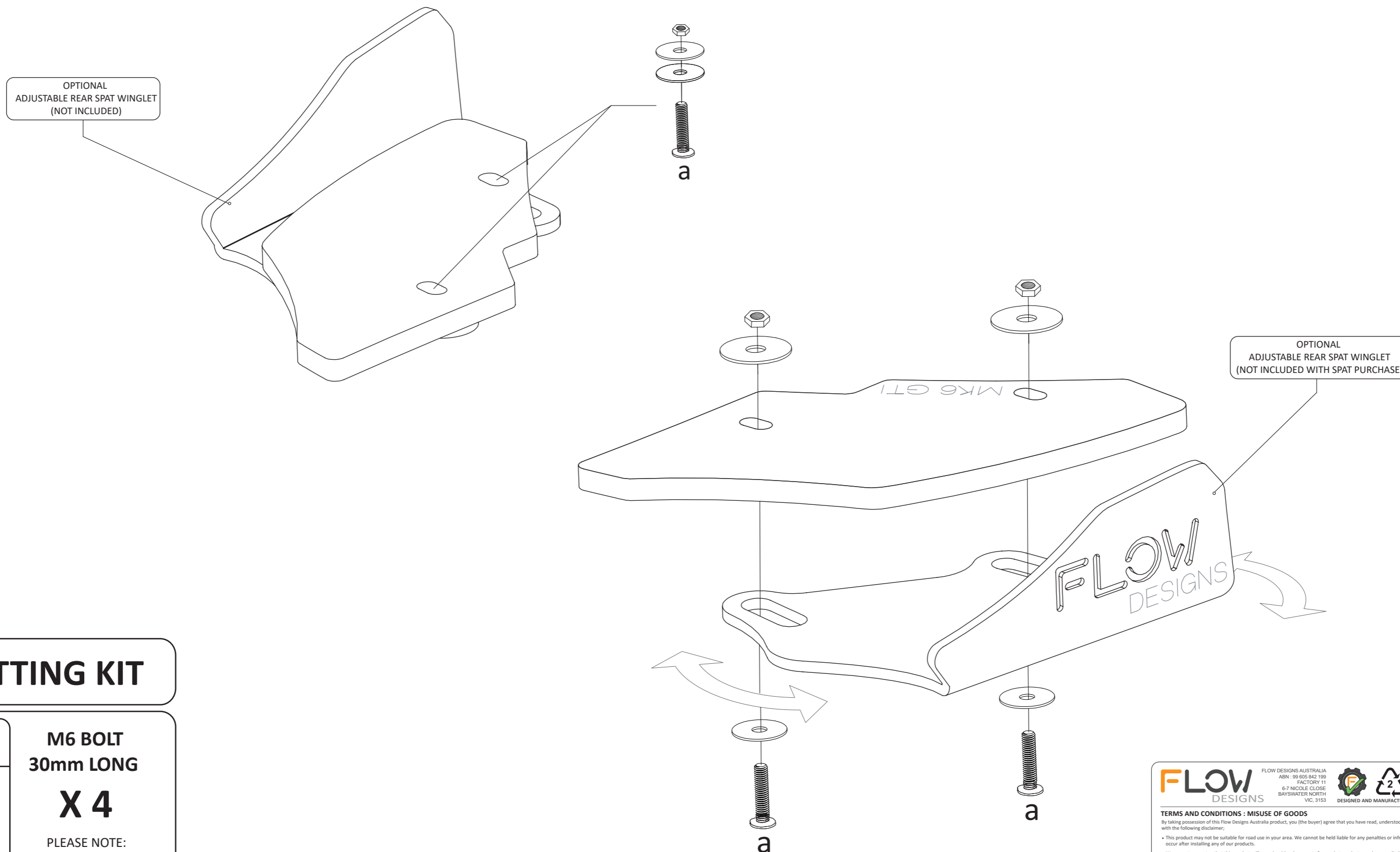

## FITTING KIT

a

M6 BOLT  
30mm LONG

X 4

PLEASE NOTE:  
DRILLING REQUIRED  
TO FASTEN TO BUMPER

PLEASE USE 8mm DRILL BIT

