

FITTING DIAGRAM

VW AW POLO GTI: REAR DIFFUSER + FLOW-LOCK FINS

INSTALLATION AND FITTING SERVICES

If you are having any difficulties please seek professional advice from the listed International and Domestic Authorised Dealers on our website.

www.flowdesignsaustralia.com

**BUMPER REMOVAL
NOT REQUIRED**

HANDY HINTS

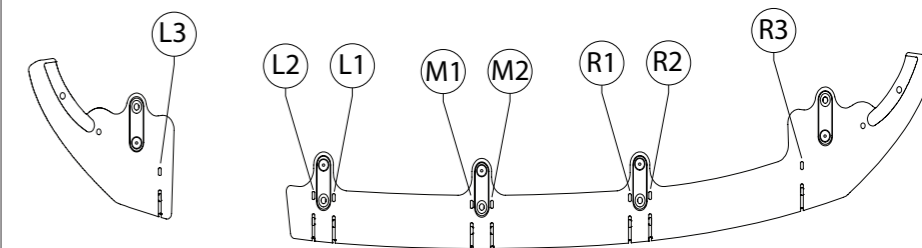

- Align FLOW-LOCK Fins to their corresponding slots.
- Please ensure to allocate the correct FLOW-LOCK Fin to the correct corresponding slot (L1 into L1 slot, R1 into R1 slot etc.)
- Ensure textured side of fin is facing out from opposing fin
- Push fin firmly into the slots until a clicking sound is heard.
- Check both top and bottom locking tabs have securely seated.

Please Note : Once fins have been locked into position, they will be difficult to remove.

FITTING KIT

a

**M6 BOLT
40mm LONG**

X 3

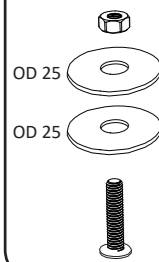

PLEASE NOTE:
DRILLING **REQUIRED**
TO FASTEN TO BUMPER
PLEASE USE 8mm DRILL BIT

b

**SELF DRILLING SCREWS
8g 38mm LONG**

X 2

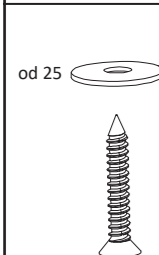

PLEASE NOTE:
REPLACES OEM SCREWS

c

**M6 BOLT
40mm LONG**

X 2

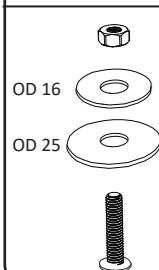

PLEASE NOTE:
DRILLING **REQUIRED**
TO FASTEN TO BUMPER
PLEASE USE 8mm DRILL BIT

Supplied with winglet

d

**M6 BOLT
12mm LONG**

X 2

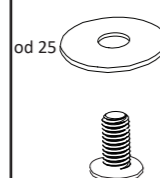

OPTIONAL
ADJUSTABLE REAR SPAT WINGLET
(NOT INCLUDED)

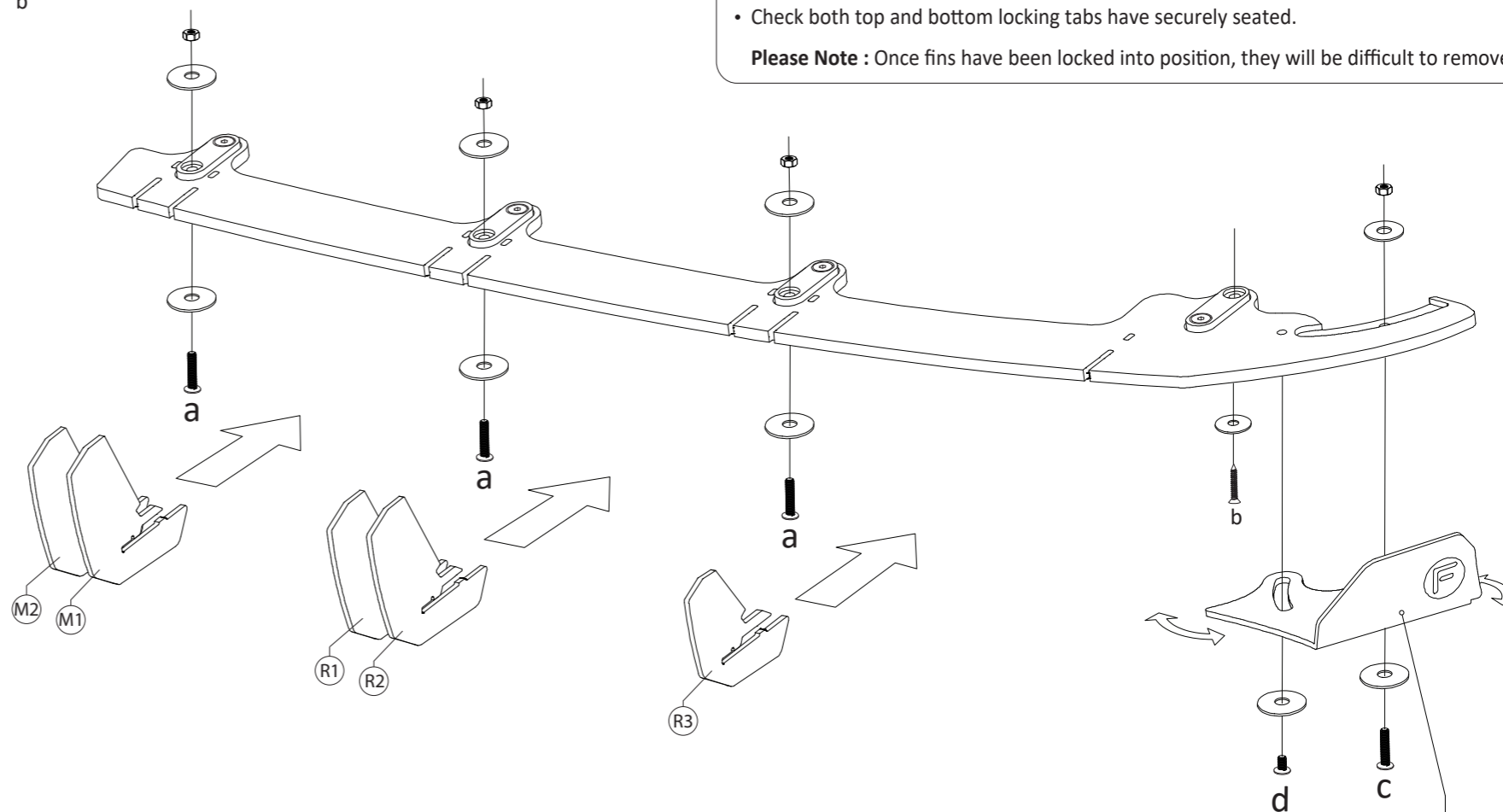
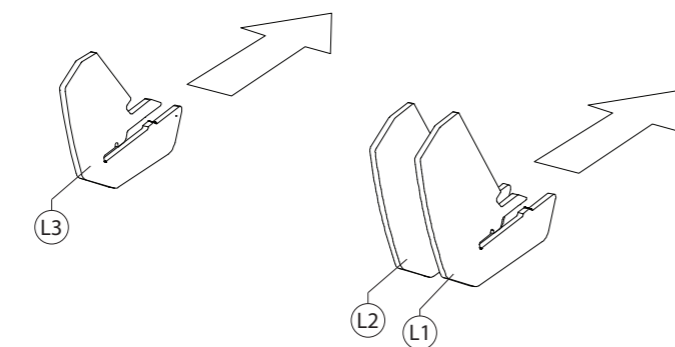
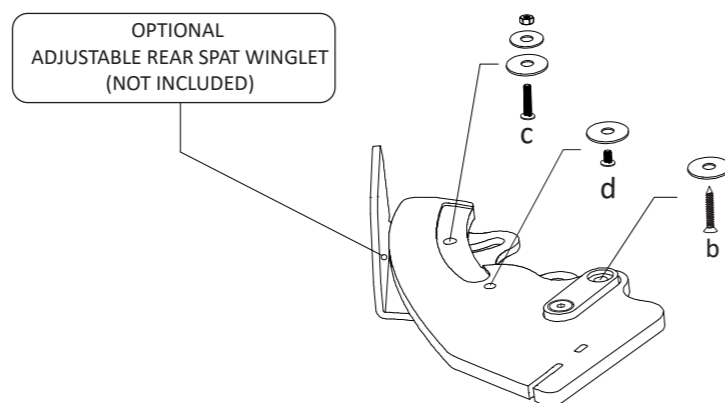

OPTIONAL
ADJUSTABLE REAR SPAT WINGLET
(NOT INCLUDED)