

# FITTING DIAGRAM

TOYOTA MZEA12R COROLLA ASCENT SPORT + SX : REAR DIFFUSER + FLOW-LOCK FINS

## INSTALLATION AND FITTING SERVICES

If you are having any difficulties please seek professional advice from the listed International and Domestic Authorised Dealers on our website.

[www.flowdesignsaustralia.com](http://www.flowdesignsaustralia.com)

# BUMPER REMOVAL NOT REQUIRED

## HANDY HINTS

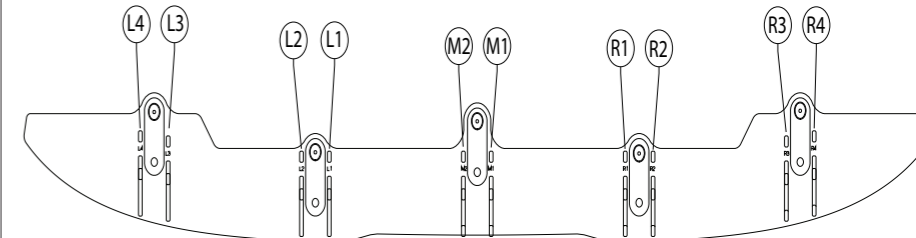

- Align FLOW-LOCK Fins to their corresponding slots.
- Please ensure to allocate the correct FLOW-LOCK Fin to the correct corresponding slot (L1 into L1 slot, R1 into R1 slot etc.)
- Ensure textured side of fin is facing out from opposing fin
- Push fin firmly into the slots until a clicking sound is heard.
- Check both top and bottom locking tabs have securely seated.

**Please Note :** Once fins have been locked into position, they will be difficult to remove.

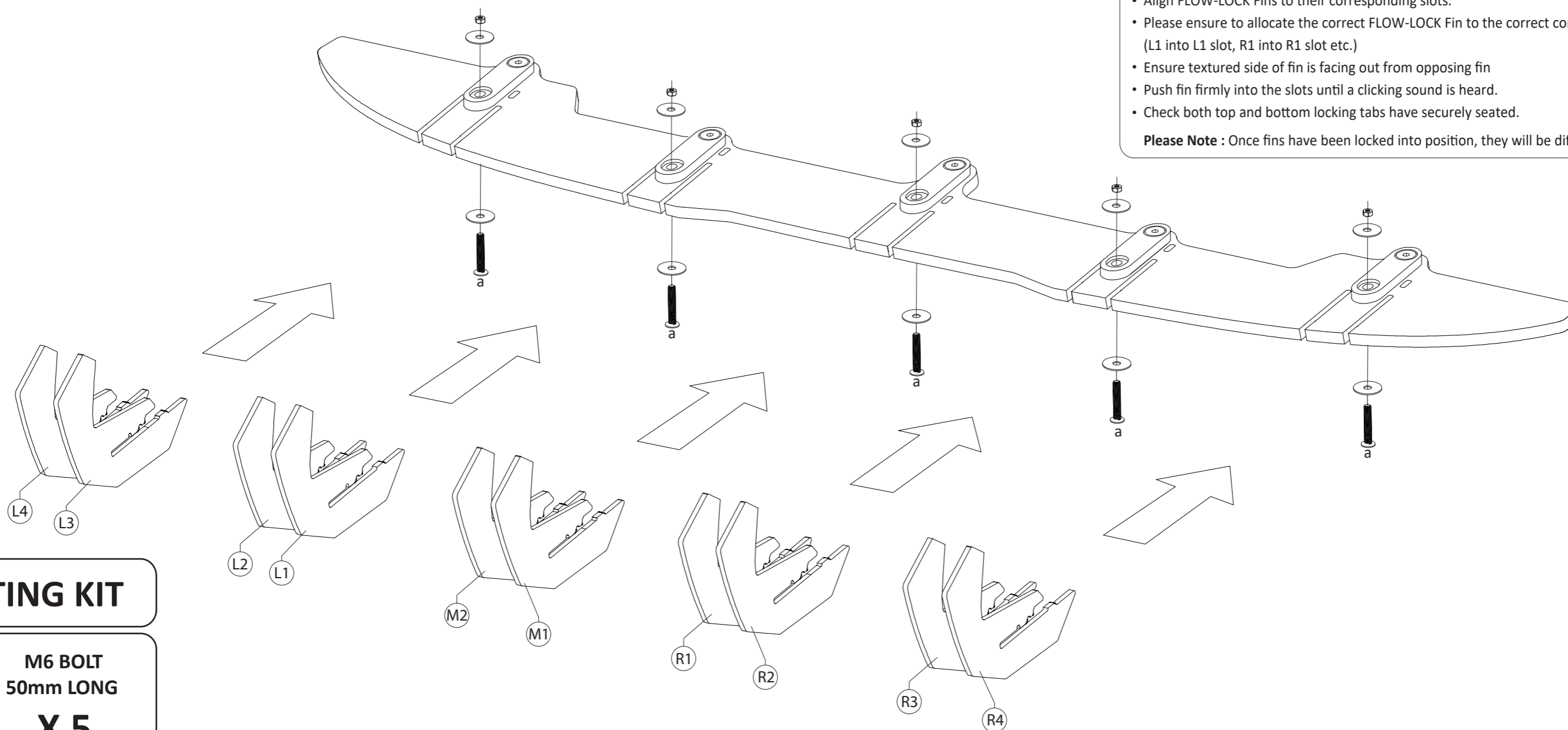

## FITTING KIT

a

M6 BOLT  
50mm LONG

X 5

PLEASE NOTE:  
DRILLING REQUIRED  
TO FASTEN TO BUMPER

PLEASE USE 8mm DRILL BIT

